

FEATURES

- Offset Voltage 50 μ V Max
- Offset Voltage Drift 1 μ V/ $^{\circ}$ C Max
- Bias Current 250pA Max
- Offset Current 250pA Max
- Bias and Offset Current Drift 4pA/ $^{\circ}$ C Max
- Supply Current 560 μ A Max
- 0.1Hz to 10Hz Noise 0.5 μ Vp-p, 2.2pAp-p
- CMRR 115dB Min
- Voltage Gain 117dB Min
- PSRR 114dB Min
- Guaranteed Operation on Two NiCad Batteries

APPLICATIONS

- Replaces OP-07/OP-77/OP-97/OP-177/AD707/LT1001 with Improved Price/Performance
- High Impedance Difference Amplifiers
- Logarithmic Amplifiers (Wide Dynamic Range)
- Thermocouple Amplifiers
- Precision Instrumentation
- Active Filters (with Small Capacitors)

DESCRIPTION

LT[®]1097 achieves a new standard in combining low price and outstanding precision performance.

On all operational amplifier data sheets, the specifications listed on the front page are for highly selected, expensive grades, while the specs for the low cost grades are buried deep in the data sheet.

The LT1097 does not have any selected grades, the outstanding specifications shown in the Features section are for its only grade.

The design effort of the LT1097 concentrated on optimizing the performance of all precision specs—at only 350 μ A of supply current. Typical values are 10 μ V offset voltage, 40pA bias and offset currents, 0.2 μ V/ $^{\circ}$ C and 0.4pA/ $^{\circ}$ C drift. Common mode and power supply rejections, voltage gain are typically in excess of 128dB.

All parameters that are important for precision, low power op amps have been optimized. Consequently, using the LT1097 error budget calculations in most applications is unnecessary.

LT, LTC and LT are registered trademarks of Linear Technology Corporation.

TYPICAL APPLICATION

Saturated Standard Cell Amplifier

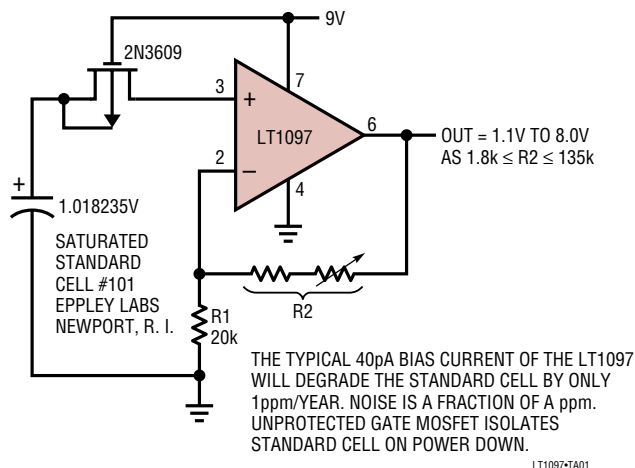

Input Offset Voltage Distribution

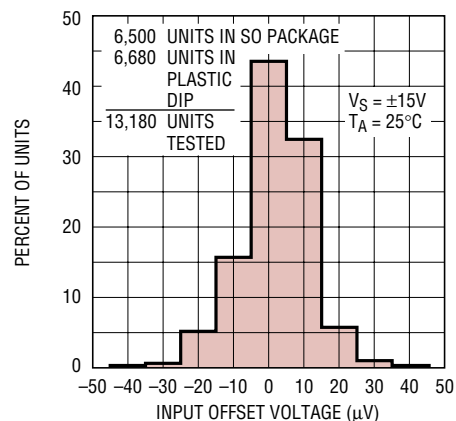

ABSOLUTE MAXIMUM RATINGS

Supply Voltage $\pm 20V$
 Differential Input Current (Note 1) $\pm 10mA$
 Input Voltage $\pm 20V$
 Output Short Circuit Duration Indefinite

Operating Temperature Range $-40^{\circ}C$ to $85^{\circ}C$
 Storage Temperature Range $-65^{\circ}C$ to $150^{\circ}C$
 Lead Temperature (Soldering, 10 sec) $300^{\circ}C$

PACKAGE/ORDER INFORMATION

<p>TOP VIEW</p> <p>N8 PACKAGE 8-LEAD PLASTIC DIP</p>	<p>ORDER PART NUMBER</p> <p>LT1097CN8</p>	<p>TOP VIEW</p> <p>S8 PACKAGE 8-LEAD PLASTIC SO</p>	<p>ORDER PART NUMBER</p> <p>LT1097S8</p>
--	---	---	--

ELECTRICAL CHARACTERISTICS $V_S = \pm 15V, V_{CM} = 0V, T_A = 25^{\circ}C$, unless otherwise noted.

SYMBOL	PARAMETER	CONDITIONS	LT1097CN8			LT1097S8			UNITS
			MIN	TYP	MAX	MIN	TYP	MAX	
V_{OS}	Input Offset Voltage			10	50		10	60	μV
$\frac{\Delta V_{OS}}{\Delta TIME}$	Long Term Input Offset Voltage Stability			0.3			0.3		$\mu V/Mo$
I_{OS}	Input Offset Current			40	250		60	350	μA
I_B	Input Bias Current			± 40	± 250		± 50	± 350	μA
e_n	Input Noise Voltage	0.1Hz to 10Hz		0.5			0.5		$\mu Vp-p$
	Input Noise Voltage Density	$f_0 = 10Hz$ $f_0 = 1000Hz$		16 14			16 14		nV/\sqrt{Hz} nV/\sqrt{Hz}
i_n	Input Noise Current	0.1Hz to 10Hz		2.2			2.4		$pAp-p$
	Input Noise Current Density	$f_0 = 10Hz$ $f_0 = 1000Hz$		0.03 0.008			0.035 0.008		pA/\sqrt{Hz} pA/\sqrt{Hz}
	Input Resistance Differential Mode Common Mode	(Note 2)	30	80 10^{12}		25	70 $8 \cdot 10^{11}$		$M\Omega$ Ω
	Input Voltage Range		± 13.5	± 14.3		± 13.5	± 14.3		V
CMRR	Common Mode Rejection Ratio	$V_{CM} = \pm 13.5V$	115	130		115	130		dB
PSRR	Power Supply Rejection Ratio	$V_S = \pm 1.2V$ to $\pm 20V$	114	130		114	130		dB
A_{VOL}	Large Signal Voltage Gain	$V_O = \pm 12V, R_L = 10k$	700	2500		700	2500		V/mV
		$V_O = \pm 10V, R_L = 2k$	250	1000		250	1000		V/mV
V_{OUT}	Output Voltage Swing	$R_L = 10k$	± 13	± 13.8		± 13	± 13.8		V
		$R_L = 2k$	± 11.5	± 13		± 11.5	± 13		V
SR	Slew Rate		0.1	0.2		0.1	0.2		$V/\mu s$
GBW	Gain Bandwidth Product			700		700			kHz
I_S	Supply Current			350	560		350	560	μA
	Offset Adjustment Range	$R_{POT} = 10k$, Wiper to V^+		± 600			± 600		μV
	Minimum Supply Voltage	(Note 3)	± 1.2	—		± 1.2	—		V

ELECTRICAL CHARACTERISTICS $V_S = \pm 15V$, $V_{CM} = 0V$, $0^\circ C \leq T_A \leq 70^\circ C$, unless otherwise noted.

SYMBOL	PARAMETER	CONDITIONS		LT1097CN8			LT1097S8			UNITS
				MIN	TYP	MAX	MIN	TYP	MAX	
V_{OS}	Input Offset Voltage		●		20	100		20	130	μV
	Average Temperature Coefficient of Input Offset Voltage	(Note 4)	●		0.2	1		0.2	1.4	$\mu V/^\circ C$
I_{OS}	Input Offset Current		●		60	430		75	570	μA
	Average Temperature Coefficient of Input Offset Current	(Note 4)	●		0.4	4		0.5	5	$\mu A/^\circ C$
I_B	Input Bias Current		●		± 60	± 430		± 75	± 570	μA
	Average Temperature Coefficient of Input Bias Current	(Note 4)	●		0.4	4		0.5	5	$\mu A/^\circ C$
A_{VOL}	Large Signal Voltage Gain	$V_{OUT} = \pm 12V$, $R_L \geq 10k$ $V_{OUT} = \pm 10V$, $R_L \geq 2k$	● ●	450 180	2000 800		450 180	2000 800		V/mV V/mV
CMRR	Common Mode Rejection Ratio	$V_{CM} = \pm 13.5V$	●	112	128		112	128		dB
PSRR	Power Supply Rejection Ratio	$V_S = \pm 1.3V$ to $\pm 20V$	●	111	128		111	128		dB
	Input Voltage Range		●	± 13.5	± 14.2		± 13.5	± 14.2		V
V_{OUT}	Output Voltage Swing	$R_L = 10k$	●	± 13	± 13.7		± 13	± 13.7		V
I_S	Supply Current		●		380	700		380	700	μA

ELECTRICAL CHARACTERISTICS $V_S = \pm 15V$, $V_{CM} = 0V$, $-40^\circ C \leq T_A \leq 85^\circ C$, unless otherwise noted. (Note 5)

SYMBOL	PARAMETER	CONDITIONS		LT1097CN8			LT1097S8			UNITS
				MIN	TYP	MAX	MIN	TYP	MAX	
V_{OS}	Input Offset Voltage		●		25	130		30	170	μV
	Average Temperature Coefficient of Input Offset Voltage		●		0.3	1.2		0.3	1.6	$\mu V/^\circ C$
I_{OS}	Input Offset Current		●		70	600		85	750	μA
	Average Temperature Coefficient of Input Offset Current		●		0.5	5		0.6	6	$\mu A/^\circ C$
I_B	Input Bias Current		●		± 70	± 600		± 85	± 750	μA
	Average Temperature Coefficient of Input Bias Current		●		0.5	5		0.6	6	$\mu A/^\circ C$
A_{VOL}	Large Signal Voltage Gain	$V_{OUT} = \pm 12V$, $R_L \geq 10k$ $V_{OUT} = \pm 10V$, $R_L \geq 2k$	● ●	300 300	1700 1700		300 300	1700 1700		V/mV V/mV
CMRR	Common Mode Rejection Ratio	$V_{CM} = \pm 13.5V$	●	108	127		108	127		dB
PSRR	Power Supply Rejection Ratio	$V_S = \pm 1.5V$ to $\pm 20V$	●	108	127		108	127		dB
	Input Voltage Range		●	± 13.5	± 14		± 13.5	± 14		V
V_{OUT}	Output Voltage Swing	$R_L = 10k$	●	± 13	± 13.6		± 13	± 13.6		V
I_S	Supply Current		●		400	800		400	800	μA

The ● denotes specifications which apply over the full operating temperature range.

Note 1: Differential input voltages greater than 1V will cause excessive current to flow through the input protection diodes unless limiting resistance is used.

Note 2: This parameter is guaranteed by design and is not tested.

Note 3: Power supply rejection ratio is measured at the minimum supply voltage.

Note 4: This parameter is not 100% tested.

Note 5: The LT1097 is designed, characterized and expected to meet these extended temperature limits, but is not tested at $-40^\circ C$ and $85^\circ C$. Guaranteed I grade parts are available; consult factory.

TYPICAL PERFORMANCE CHARACTERISTICS

Distribution to Offset Voltage Drift with Temperature

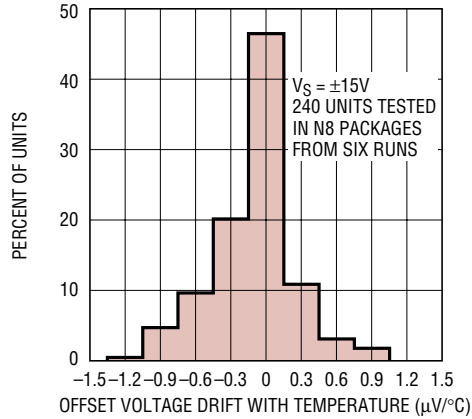

LT1097 • G02

Input Bias Current vs Temperature

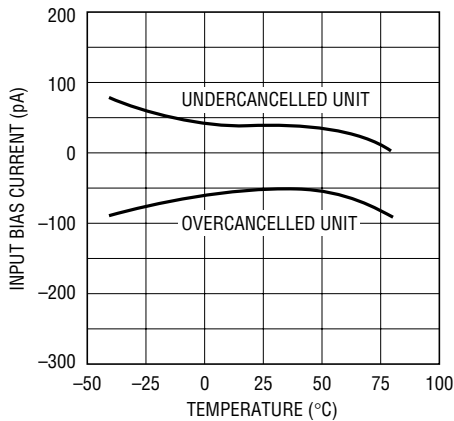

1097 • G03

Minimum Supply Voltage, Common Mode Range and Voltage Swing at V_{MIN}

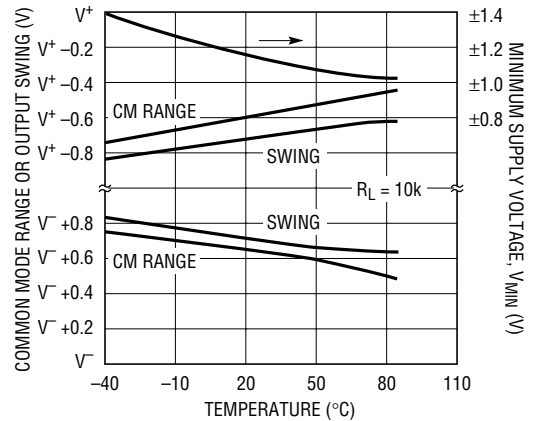

1097 • G04

Warm-Up Drift

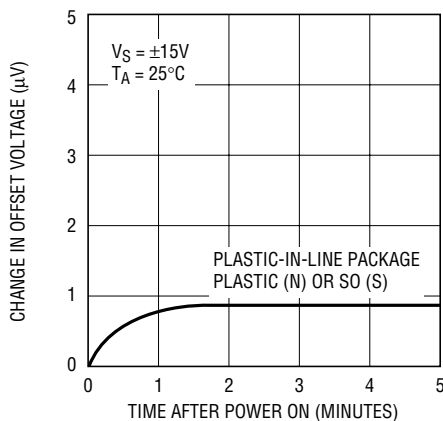

1097 • G05

Input Bias Current Over Common Mode Range

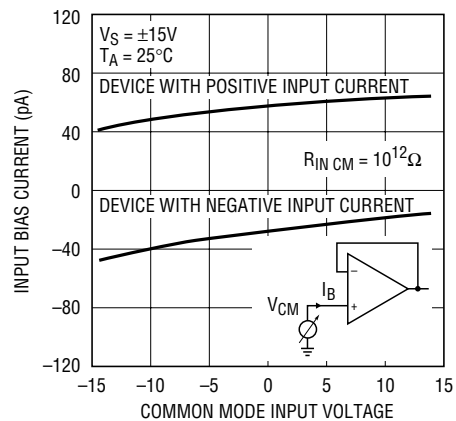

1097 • G06

TYPICAL PERFORMANCE CHARACTERISTICS

Output Short Circuit Current vs Time

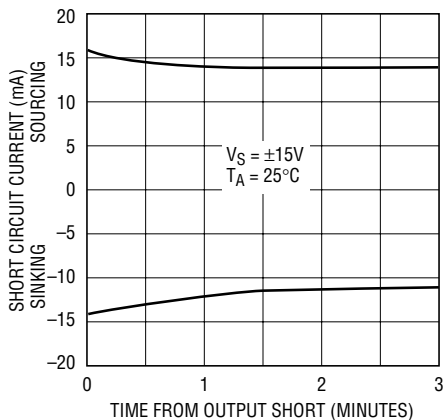

1097 • G07

0.1Hz to 10Hz Noise

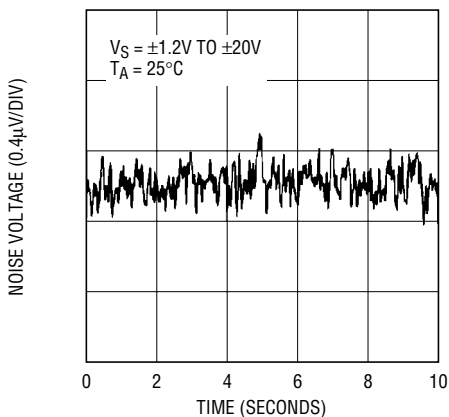

1097 • G08

0.01Hz to 10Hz Noise

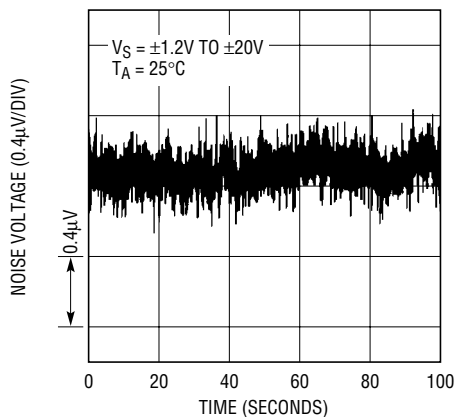

1097 • G09

Noise Spectrum

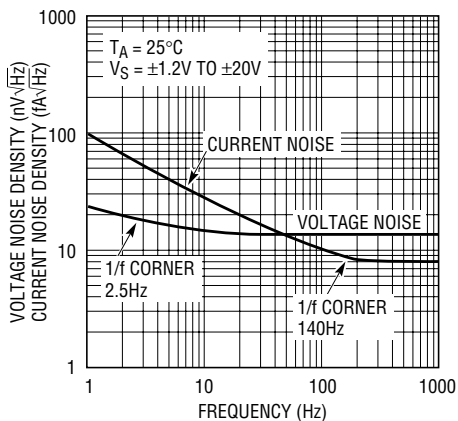

1097 • G10

Voltage Gain

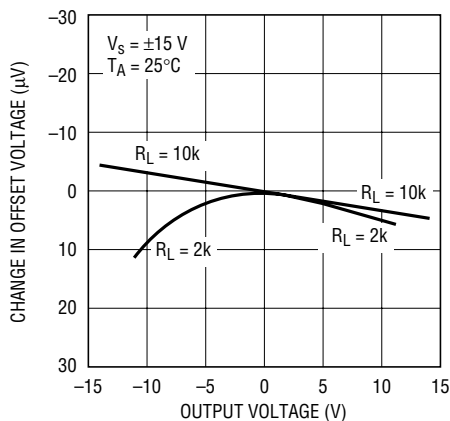

1097 • G11

TYPICAL PERFORMANCE CHARACTERISTICS

Voltage Gain vs Frequency

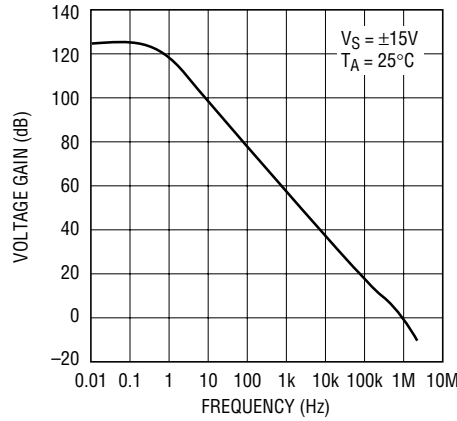

Gain, Phase Shift vs Frequency

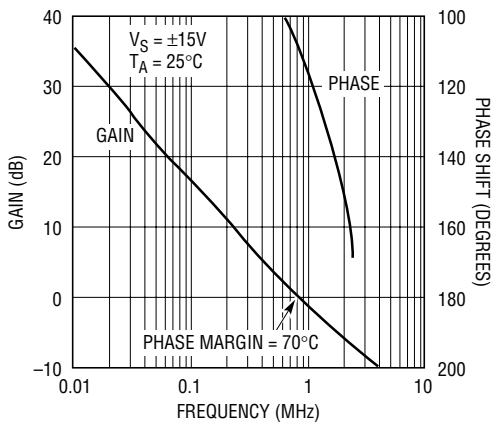

Common Mode Rejection vs Frequency

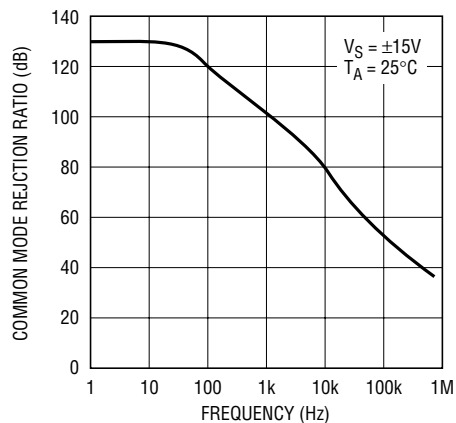

Power Supply Rejection vs Frequency

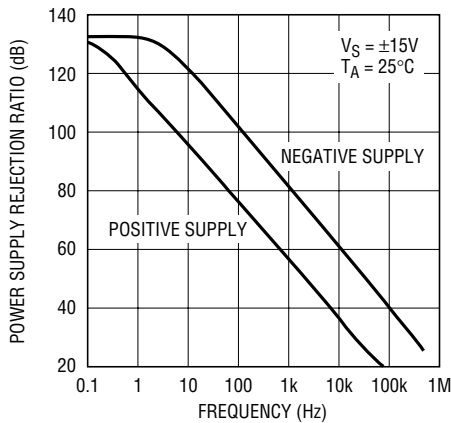

Slew Rate, Gain Bandwidth Product vs Overcompensation Capacitor

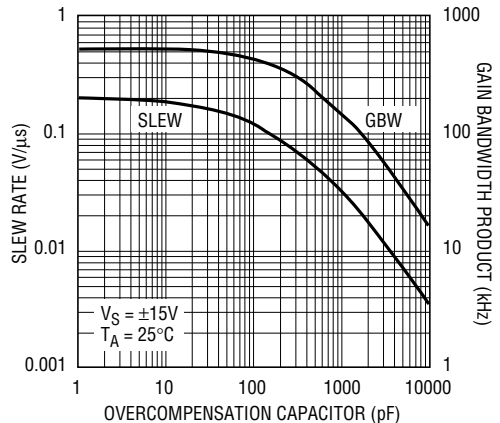

TYPICAL PERFORMANCE CHARACTERISTICS

Small Signal Transient Response

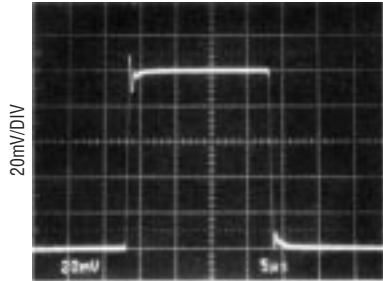

$A_V = 1$, $C_{LOAD} = 100\text{pF}$, $5\mu\text{s}/\text{DIV}$ 1097 G17

Large Signal Transient Response

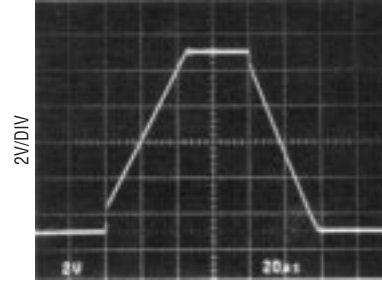

$A_V = 1$, $20\mu\text{s}/\text{DIV}$ 1097 G18

Capacitive Load Handling

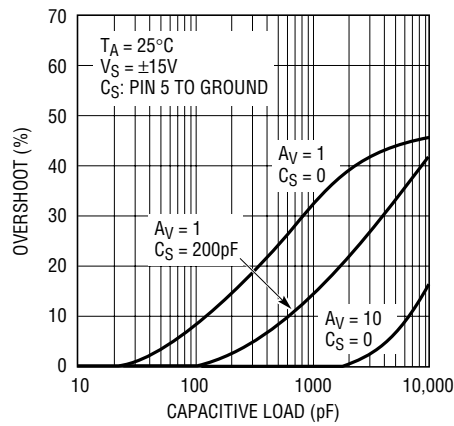

1097 G19

SCHEMATIC DIAGRAM

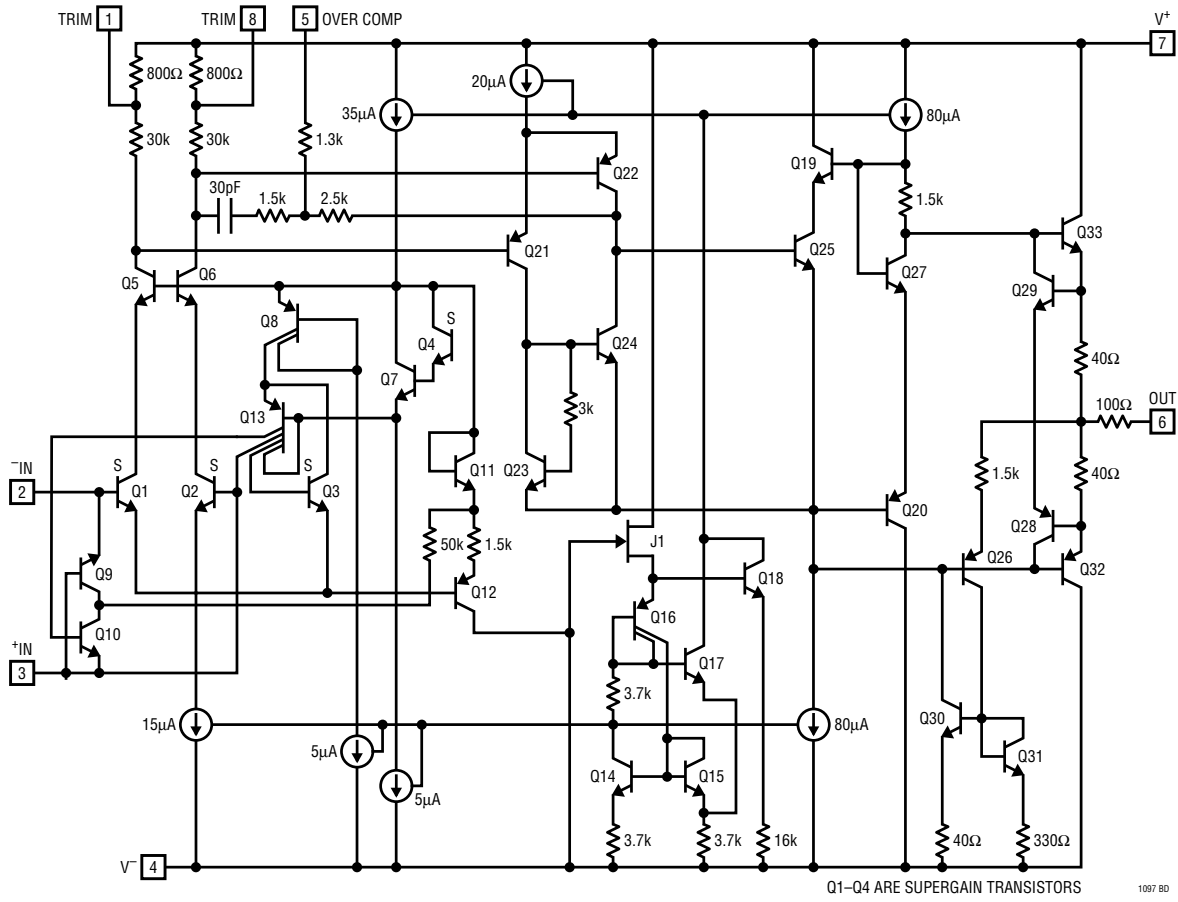

1097 BD

APPLICATIONS INFORMATION

The LT1097 is pin compatible to and directly replaces such precision op amps as the OP-07, OP-77, AD707, OP-97, OP-177, LM607 and LT1001 with improved price/performance. Compatibility includes externally nulling the offset voltage, as all of the above devices are trimmed with a potentiometer between Pin 1 and Pin 8 and the wiper tied to V^+ .

The simple difference amplifier can be used to illustrate the all-around excellence of the LT1097. The 50k input resistance is selected to be large enough compared to input signal source resistance. Simultaneously, the 50k resistors should not dominate the precision and noise error budget. Assuming perfect matching between the four resistors, the following table summarizes the input

referred performance obtained using the LT1097 and other popular, low cost precision op amps.

Input offset voltage can be adjusted over a $\pm 600\mu\text{V}$ range with a 10k potentiometer.

The LT1097 is internally compensated for unity gain stability. As shown on the Capacitive Load Handling plot, the LT1097 is stable with any capacitive load. However, the overcompensation capacitor, C_S , can be used to reduce overshoot with heavy capacitive loads, to narrow noise bandwidth or to stabilize circuits with gain in the feedback loop.

$\pm 27\text{V}$ Common Mode Range Difference Amplifier

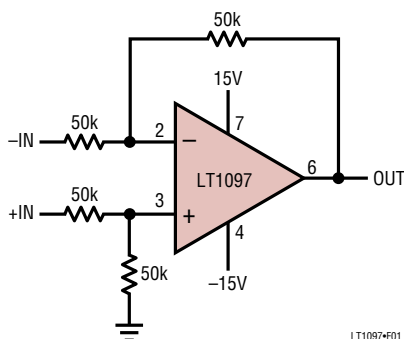

Frequency Compensation and Optional Offset Nulling

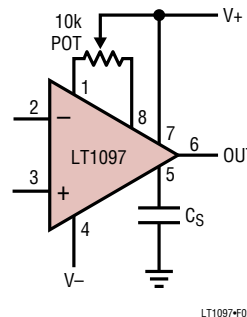

Guaranteed Performance, $V_S = \pm 15\text{V}$, $T_A = 25^\circ\text{C}$

PARAMETER	LT1097CN8	OP-77GP	AD707JN	OP-177GP	OP-97FP	UNITS
Error Terms						
V_{OS} Max	50	100	90	60	75	μV
I_{OS} Max*25k	6	70	50	70	4	μV
Gain Min, 10V Out	14	5	3	5	50	μV
CMRR, Min, $\pm 25\text{V}$ In	22	20	13	22	39	μV
PSRR, Min, $V_S = \pm 15\text{V} \pm 10\%$	6	9	9	9	9	μV
Sum of All Error Terms	98	204	165	166	177	μV
0.1Hz to 10Hz Noise						
Voltage Noise	0.5	0.38	0.23	0.38	0.5	$\mu\text{Vp-p}$ Typ
Current Noise*50k	0.11	0.75	0.7	0.75	0.1	$\mu\text{Vp-p}$ Typ
Resistor Noise	0.55	0.55	0.55	0.55	0.55	$\mu\text{Vp-p}$ Typ
RMS sum	0.75	1	0.92	1	0.75	$\mu\text{Vp-p}$
Drift with Temp						
TCV_{OS} Max	1	1.2	1	1.2	2	$\mu\text{V}/^\circ\text{C}$
TCI_{OS} Max*25k	0.1	2.1	1	2.1	0.2	$\mu\text{V}/^\circ\text{C}$
Sum of Drift Terms	1.1	3.3	2	3.3	2.2	$\mu\text{V}/^\circ\text{C}$
Supply Current Max	0.56	2	3	2	0.6	mA

APPLICATIONS INFORMATION

The availability of the compensation terminal permits the use of feedforward frequency compensation to enhance slew rate. The voltage follower feedforward scheme bypasses the amplifier's gain stages and slews at nearly 10V/ μ s.

The inputs of the LT1097 are protected with back-to-back diodes. In the voltage follower configuration, when the input is driven by a fast, large signal pulse (>1V), the input

protection diodes effectively short the output to the input during slewing, and a current, limited only by the output short circuit protection will flow through the diodes.

The use of a feedback resistor, as shown in the voltage follower feedforward diagram, is recommended because this resistor keeps the current below the short circuit limit, resulting in faster recovery and settling of the output.

Follower Feedforward Compensation

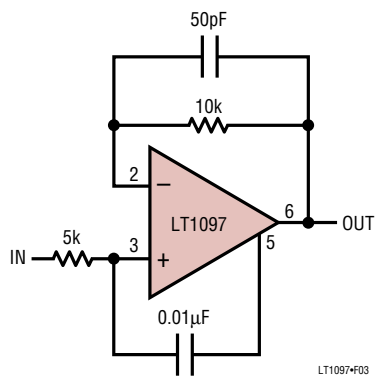

Pulse Response of Feedforward Compensation

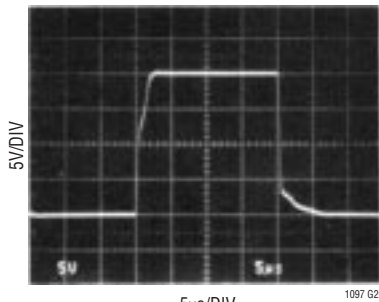

Test Circuit for Offset Voltage and its Drift with Temperature

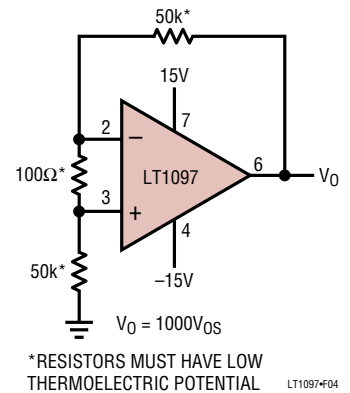

TYPICAL APPLICATION

Low Power Comparator with <math><10\mu\text{V}</math> Hysteresis

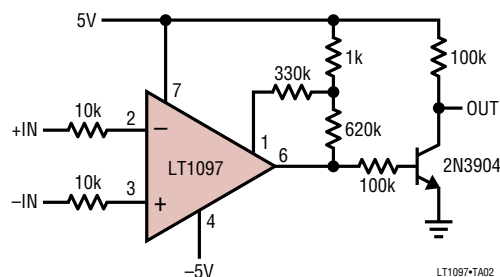

PACKAGE DESCRIPTION Dimensions in inches (millimeters) unless otherwise noted.

N8 Package
8-Lead PDIP (Narrow 0.300)
 (LTC DWG # 05-08-1510)

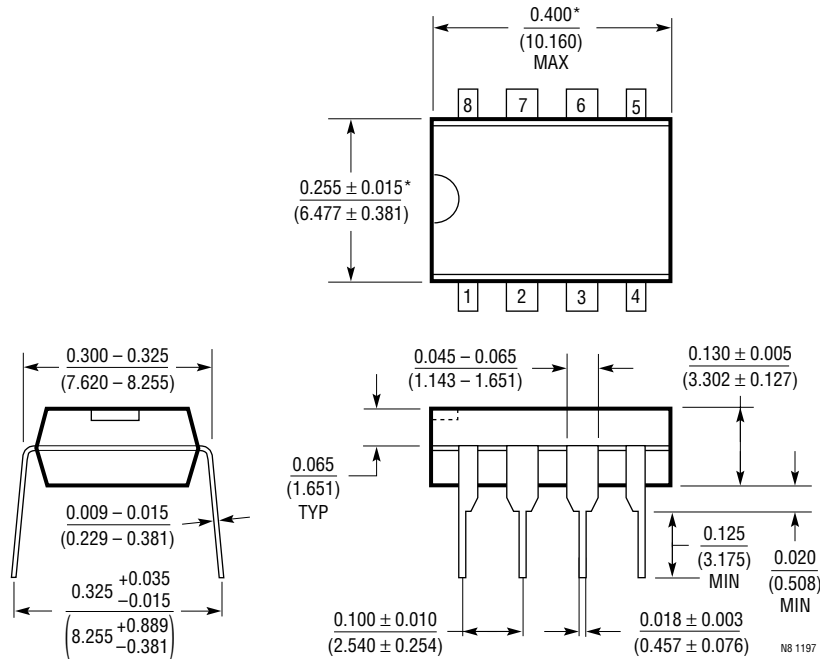

*THESE DIMENSIONS DO NOT INCLUDE MOLD FLASH OR PROTRUSIONS.
 MOLD FLASH OR PROTRUSIONS SHALL NOT EXCEED 0.010 INCH (0.254mm)

S8 Package
8-Lead Plastic Small Outline (Narrow 0.150)
 (LTC DWG # 05-08-1610)

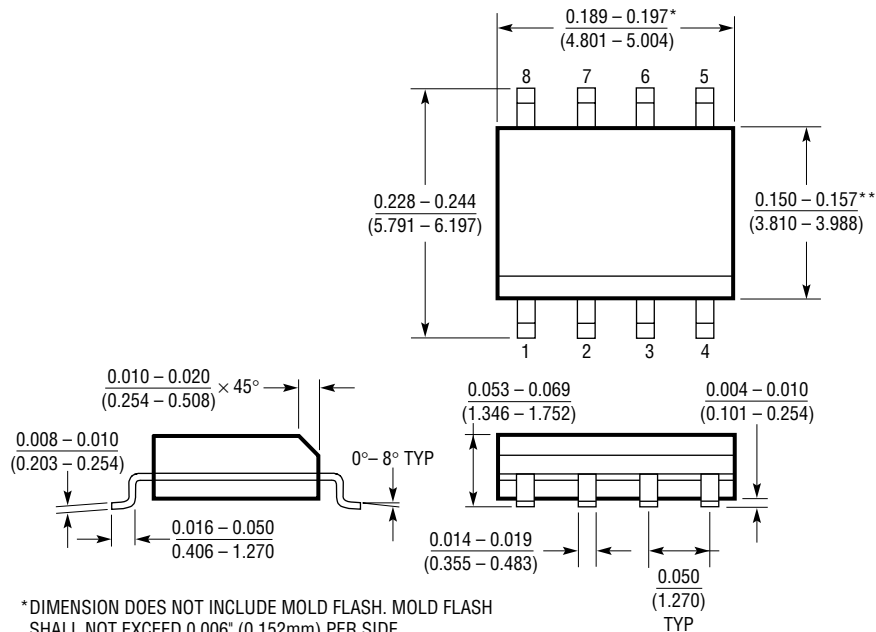

*DIMENSION DOES NOT INCLUDE MOLD FLASH. MOLD FLASH SHALL NOT EXCEED 0.006" (0.152mm) PER SIDE

**DIMENSION DOES NOT INCLUDE INTERLEAD FLASH. INTERLEAD FLASH SHALL NOT EXCEED 0.010" (0.254mm) PER SIDE

S08 0996

TYPICAL APPLICATION

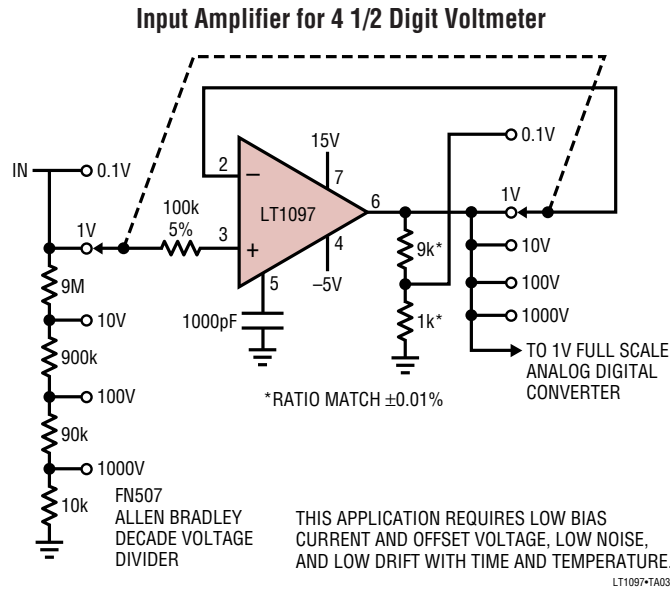

RELATED PARTS

PART NUMBER	DESCRIPTION	COMMENTS
LT1490/LT1491	Dual/Quad General Purpose Micropower Rail-to-Rail Op Amps	Over-The-Top™ Inputs, 50µA Supply Current Per Amplifier, 2V to 44V Supply Range, 180kHz GBW
LT1492/LT1493	Dual/Quad 5MHz Low Power Single Supply Op Amps	180µV V_{OS} Max, 3V/µs Slew Rate, 550µA Supply Per Amplifier
LT1077	Single Micropower Low V_{OS} Op Amp	60µV V_{OS} Max, 68µA Supply Current, 230kHz GBW, Optimized for 5V Supplies

Over-The-Top is a trademark of Linear Technology Corporation.