



Features

- Surface Mount / Single-Turn Cermet / Process Sealed
- Elastomer seal allows multiple adjustments (5 rotations)
- Compatible with all surface mount manufacturing processes
- Recommended for reflow processing only

- Cross-slot rotor design suitable for automatic adjustment equipment
- Supplied in 12mm embossed tape, compatible with automatic pick-and-place assembly equipment
- Patent #5,095,298
- Plastic rotor minimizes RF & ESD concerns

3374 - 4mm Square Trimming Potentiometer

Electrical Characteristics

Standard Resistance Range10 to 2 megohms
 (see standard resistance table)
 Resistance Tolerance±20% std.
 End Resistance.....1% or 2 ohms max.
 (whichever is greater)
 Contact Resistance Variation
3% or 3 ohms max.
 (whichever is greater)
 Resolution.....Infinite
 Adjustment Angle240° nom.
 Maximum Voltage200V

Environmental Characteristics

Power Rating
 70°C.....0.25 watt
 125°C.....0 watt
 Operating Temperature Range
-55°C to +125°C
 Temperature Coefficient
 <500K ohms.....±100ppm/°C
 ≥500K ohms.....±150ppm/°C
 Seal5 turns min.
 HumidityMIL-STD 202 Method 100
 Vibration20G; TRS ±1%, VRS ±1%
 Shock.....100G; TRS ±1%, VRS ±1%
 Load Life (@70°C Rated Power)
 1000 hours)3 cycles
 Rotational Life100 cycles TRS ±1%
 Thermal Shock5 cycles
 TRS ±2%, VRS ±1%

Physical Characteristics

Torque.....18 - 180 mN-c
 Mechanical AngleContinuous
 MarkingManufacturer's trademark
 and part marking code
 WiperPositioned at 50% nominal
 Standard Packaging750 pcs./7" reel
 Adjustment ToolH-90

How To Order

Model 3374 X - 1 - 502 E

Style _____

Orientation of Parts in Tape:
 Style W - Terminals Toward
 Sprocket Holes

Standard or Modified
 Product Indicator
 -1 = Standard Product

Resistance Code _____

Embossed Tape
 750 pcs./7" reel (standard)

Consult factory for other available options.

3374X/W

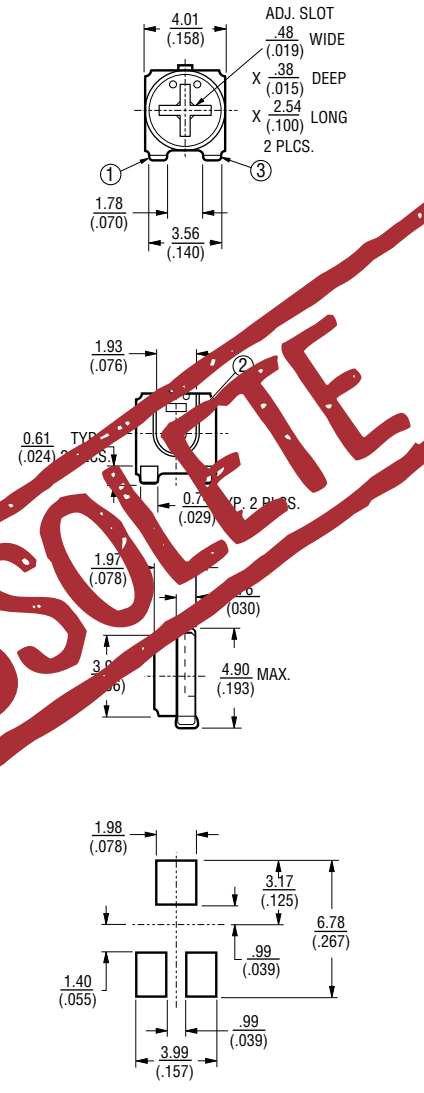

Packaging Specifications

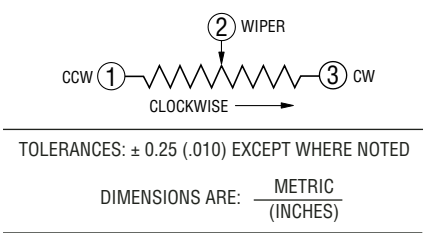
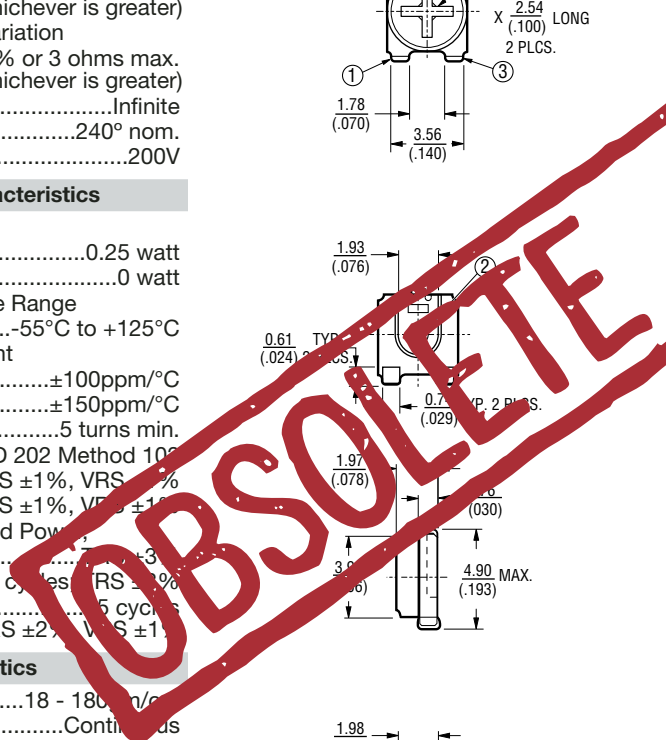
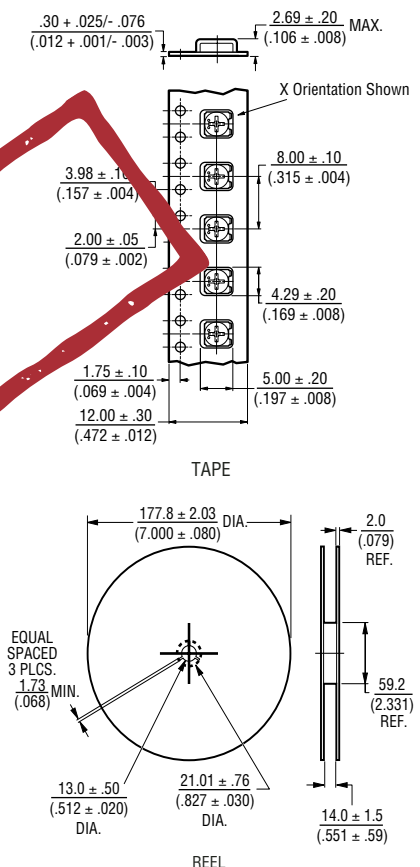

Meets EIA 481

Standard Resistance Table

Resistance (Ohms)	Part Marking Code	Resistance Code
10	A1	100
20	21	200
50	51	500
100	A2	101
200	22	201
500	52	501
1,000	A3	102
2,000	23	202
5,000	53	502
10,000	A4	103
20,000	24	203
50,000	54	503
100,000	A5	104
200,000	25	204
500,000	55	504
1,000,000	A6	105
2,000,000	26	205

Popular values listed in boldface. Special resistances available.
 SHADED AREAS TYPICALLY NOT STOCKED BY DISTRIBUTORS AND NOT RECOMMENDED FOR NEW DESIGNS.

Specifications are subject to change without notice.