

REVISIONS			
LTR	DESCRIPTION	DATE (YR-MO-DA)	APPROVED
A	Change to the supply current test, I_{CC} , in table I. Update boilerplate. -rrp	99-11-16	R. MONNIN
B	Add radiation hardness requirements. Add case outline D. Add table IIB. -rrp	00-05-05	R. MONNIN
C	Add footnote to the supply voltage test in section 1.3. Add footnote to the supply current and power supply rejection ratio test in table I. Update boilerplate. -rrp	01-10-17	R. MONNIN
D	Change to the post irradiation test limits in table I for I_{IO} , I_{IB} , A_{VO} , and I_{CC} . Removed accelerated aging and dose rate burnout provisions in section 4. -rrp	01-11-15	R. MONNIN
E	Added subgroup 4 to table IIA under group E end-point for device class V. -gt	03-03-11	R. MONNIN
F	Drawing updated to reflect current requirements. -rrp	05-09-07	R. MONNIN

--	--	--	--	--	--	--	--	--	--	--	--	--	--	--	--

REV																	
SHEET																	
REV																	
SHEET																	

REV STATUS	REV	F	F	F	F	F	F	F	F	F	F	F	F	F		
OF SHEETS	SHEET	1	2	3	4	5	6	7	8	9	10	11				

PMIC N/A	PREPARED BY RICK C. OFFICER	DEFENSE SUPPLY CENTER COLUMBUS COLUMBUS, OHIO 43218-3990 http://www.dscc.dla.mil													
STANDARD MICROCIRCUIT DRAWING THIS DRAWING IS AVAILABLE FOR USE BY ALL DEPARTMENTS AND AGENCIES OF THE DEPARTMENT OF DEFENSE AMSC N/A	CHECKED BY RAJESH R. PITHADIA														
	APPROVED BY MICHAEL A. FRYE														
	DRAWING APPROVAL DATE 94-03-02														
	REVISION LEVEL F	SIZE A	CAGE CODE 67268	5962-93258											
		SHEET 1 OF 11													

1.3 Absolute maximum ratings. 1/

Supply voltage (V_{CC}) 2/	± 18 V
Differential input voltage 3/	± 26 V
Input voltage 3/	± 18 V
Output short-circuit duration	Limited
Storage temperature range	-65°C to $+175^{\circ}\text{C}$
Lead temperature (soldering, 60 seconds)	$+300^{\circ}\text{C}$
Junction temperature (T_J)	-65°C to $+175^{\circ}\text{C}$
Thermal resistance, junction-to-case (θ_{JC})	See MIL-STD-1835
Thermal resistance, junction-to-ambient (θ_{JA}):	
Case C	94°C/W
Case D	140°C/W
Case 2	78°C/W

1.4 Recommended operating conditions.

Supply voltage (V_{CC})	± 15 V
Ambient operating temperature range (T_A)	-55°C to $+125^{\circ}\text{C}$

1.5 Radiation features.

Maximum total dose available (dose rate = 50 – 300 rads(Si)/s)..... 100 Krads 4/

2. APPLICABLE DOCUMENTS

2.1 Government specification, standards, and handbooks. The following specification, standards, and handbooks form a part of this drawing to the extent specified herein. Unless otherwise specified, the issues of these documents are those cited in the solicitation or contract.

DEPARTMENT OF DEFENSE SPECIFICATION

MIL-PRF-38535 - Integrated Circuits, Manufacturing, General Specification for.

DEPARTMENT OF DEFENSE STANDARDS

MIL-STD-883 - Test Method Standard Microcircuits.
MIL-STD-1835 - Interface Standard Electronic Component Case Outlines.

DEPARTMENT OF DEFENSE HANDBOOKS

MIL-HDBK-103 - List of Standard Microcircuit Drawings.
MIL-HDBK-780 - Standard Microcircuit Drawings.

(Copies of these documents are available online at <http://assist.daps.dla.mil/quicksearch/> or <http://assist.daps.dla.mil> or from the Standardization Document Order Desk, 700 Robbins Avenue, Building 4D, Philadelphia, PA 19111-5094.)

2.2 Order of precedence. In the event of a conflict between the text of this drawing and the references cited herein, the text of this drawing takes precedence. Nothing in this document, however, supersedes applicable laws and regulations unless a specific exemption has been obtained.

- 1/ Stresses above the absolute maximum rating may cause permanent damage to the device. Extended operation at the maximum levels may degrade performance and affect reliability.
- 2/ For proper operation the positive supply must be sequenced ON before the negative supply.
- 3/ For supply voltages less than ± 18 V, the absolute maximum input voltage is equal to the supply voltage.
- 4/ These parts may be dose rate sensitive in a space environment and may demonstrate enhanced low dose rate effects. Radiation end point limits for the noted parameters are guaranteed only for the conditions specified in MIL-STD-883, method 1019, condition A.

STANDARD MICROCIRCUIT DRAWING DEFENSE SUPPLY CENTER COLUMBUS COLUMBUS, OHIO 43218-3990	SIZE A		5962-93258
		REVISION LEVEL F	SHEET 3

3. REQUIREMENTS

3.1 Item requirements. The individual item requirements for device classes Q and V shall be in accordance with MIL-PRF-38535 and as specified herein or as modified in the device manufacturer's Quality Management (QM) plan. The modification in the QM plan shall not affect the form, fit, or function as described herein. The individual item requirements for device class M shall be in accordance with MIL-PRF-38535, appendix A for non-JAN class level B devices and as specified herein.

3.2 Design, construction, and physical dimensions. The design, construction, and physical dimensions shall be as specified in MIL-PRF-38535 and herein for device classes Q and V or MIL-PRF-38535, appendix A and herein for device class M.

3.2.1 Case outline. The case outline shall be in accordance with 1.2.4 herein.

3.2.2 Terminal connections. The terminal connections shall be as specified on figure 1.

3.2.3 Radiation exposure circuit. The radiation exposure circuit shall be as specified on figure 2.

3.3 Electrical performance characteristics and postirradiation parameter limits. Unless otherwise specified herein, the electrical performance characteristics and postirradiation parameter limits are as specified in table I and shall apply over the full ambient operating temperature range.

3.4 Electrical test requirements. The electrical test requirements shall be the subgroups specified in table IIA. The electrical tests for each subgroup are defined in table I.

3.5 Marking. The part shall be marked with the PIN listed in 1.2 herein. In addition, the manufacturer's PIN may also be marked. For packages where marking of the entire SMD PIN number is not feasible due to space limitations, the manufacturer has the option of not marking the "5962-" on the device. For RHA product using this option, the RHA designator shall still be marked. Marking for device classes Q and V shall be in accordance with MIL-PRF-38535. Marking for device class M shall be in accordance with MIL-PRF-38535, appendix A.

3.5.1 Certification/compliance mark. The certification mark for device classes Q and V shall be a "QML" or "Q" as required in MIL-PRF-38535. The compliance mark for device class M shall be a "C" as required in MIL-PRF-38535, appendix A.

3.6 Certificate of compliance. For device classes Q and V, a certificate of compliance shall be required from a QML-38535 listed manufacturer in order to supply to the requirements of this drawing (see 6.6.1 herein). For device class M, a certificate of compliance shall be required from a manufacturer in order to be listed as an approved source of supply in MIL-HDBK-103 (see 6.6.2 herein). The certificate of compliance submitted to DSCC-VA prior to listing as an approved source of supply for this drawing shall affirm that the manufacturer's product meets, for device classes Q and V, the requirements of MIL-PRF-38535 and herein or for device class M, the requirements of MIL-PRF-38535, appendix A and herein.

3.7 Certificate of conformance. A certificate of conformance as required for device classes Q and V in MIL-PRF-38535 or for device class M in MIL-PRF-38535, appendix A shall be provided with each lot of microcircuits delivered to this drawing.

3.8 Notification of change for device class M. For device class M, notification to DSCC-VA of change of product (see 6.2 herein) involving devices acquired to this drawing is required for any change that affects this drawing.

3.9 Verification and review for device class M. For device class M, DSCC, DSCC's agent, and the acquiring activity retain the option to review the manufacturer's facility and applicable required documentation. Offshore documentation shall be made available onshore at the option of the reviewer.

3.10 Microcircuit group assignment for device class M. Device class M devices covered by this drawing shall be in microcircuit group number 49 (see MIL-PRF-38535, appendix A).

STANDARD MICROCIRCUIT DRAWING DEFENSE SUPPLY CENTER COLUMBUS COLUMBUS, OHIO 43218-3990	SIZE A		5962-93258
		REVISION LEVEL F	SHEET 4

TABLE I. Electrical performance characteristics.

Test	Symbol	Conditions <u>1/2/</u> -55°C ≤ T _A ≤ +125°C unless otherwise specified	Group A subgroups	Device type	Limits <u>3/</u>		Unit
					Min	Max	
Input offset voltage	V _{IO}	V _{CC} = ±5 V	1	01		0.5	mV
			2, 3			1.0	
		V _{CC} = ±15 V	1			0.5	
			2, 3			1.0	
		M,D,P,L,R	1			1.5	
Input offset current	I _{IO}	V _{CC} = ±5 V, V _{CM} = 0 V	1	01		100	nA
			2, 3			150	
		V _{CC} = ±15 V, V _{CM} = 0 V	1			100	
			2, 3			150	
		M,D,P,L,R	1			300	
Input bias current	I _{IB}	V _{CC} = ±5 V, V _{CM} = 0 V	1	01		600	nA
			2, 3			700	
		V _{CC} = ±15 V, V _{CM} = 0 V	1			600	
			2, 3			700	
		M,D,P,L,R	1			2000	
Common mode rejection ratio	CMRR	V _{CC} = ±5 V, V _{CM} = ±2 V <u>4/</u>	1, 2, 3	01	76		dB
		V _{CC} = ±15 V, V _{CM} = ±12 V <u>4/</u>			80		
Large signal voltage gain	A _{VO}	V _{CC} = ±5 V, R _L = 2 kΩ	4	01	80		dB
			5, 6		74		
		V _{CC} = ±15 V, R _L = 2 kΩ	4		83		
			5, 6		77.5		
		M,D,P,L,R	4		63		
Output voltage swing	V _{OUT}	V _{CC} = ±5 V, R _L = 2 kΩ <u>4/</u>	4, 5, 6	01	±3.0		V
		V _{CC} = ±15 V, R _L = 2 kΩ <u>4/</u>	4		±13		
			5, 6		±12.9		

See footnotes at end of table.

STANDARD MICROCIRCUIT DRAWING DEFENSE SUPPLY CENTER COLUMBUS COLUMBUS, OHIO 43218-3990	SIZE A		5962-93258
		REVISION LEVEL F	SHEET 5

TABLE I. Electrical performance characteristics - Continued

Test	Symbol	Conditions <u>1/ 2/</u> -55°C ≤ T _A ≤ +125°C unless otherwise specified	Group A subgroups	Device type	Limits <u>3/</u>		Unit
					Min	Max	
Supply current	I _{CC}	V _{CC} = ±5 V, V _{OUT} = 0 V <u>5/</u>	1	01		10	mA
			2, 3			12	
		V _{CC} = ±15 V, V _{OUT} = 0 V <u>5/</u>	1			10	
			2, 3			13	
		M,D,P,L,R	1			11	
Power supply rejection ratio	PSRR	V _{CC} = ±4.5 V to ±5.5 V <u>4/ 5/</u>	1	01	92		dB
			2, 3		83		
		V _{CC} = ±4.5 V to ±18 V <u>4/ 5/</u>	1		96		
			2, 3		86		
Input offset voltage drift	TC _{VIO}	V _{CC} = ±15 V, T _A = +125°C, -55°C <u>4/</u>	8	01		5	μV/°C
Gain bandwidth product	GBWP	V _{CC} = ±5 V, A _V = +1, C _L = 30 pF, T _A = +25°C <u>4/</u>	7	01	16		MHz
		V _{CC} = ±15 V, A _V = +1, C _L = 30 pF, T _A = +25°C <u>4/</u>			21		
Slew rate	SR	V _{CC} = ±5 V, V _{IN} = 5 V step, A _V = +1, R _L = 2 kΩ, C _L = 30 pF, T _A = +25°C <u>4/</u>	7	01	85		V/μs
		V _{CC} = ±15 V, A _V = +1, V _{IN} = 10 V step, R _L = 2 kΩ, C _L = 30 pF, T _A = +25°C <u>4/</u>			125		
Settling time	t _s	V _{CC} = ±15 V, A _V = +1, V _{IN} = 10 V step to 0.01% of the final value, T _A = +25°C <u>4/</u>	9	01		300	ns

- 1/ Devices supplied to this drawing will meet all levels M, D, P, L, R of irradiation. However, this device is only tested at the 'R' level. Pre and Post irradiation values are identical unless otherwise specified in table I. When performing post irradiation electrical measurements for any RHA level, T_A = +25°C.
- 2/ These parts may be dose rate sensitive in a space environment and may demonstrate enhanced low dose rate effects. Radiation end point limits for the noted parameters are guaranteed only for the conditions specified in MIL-STD-883, method 1019, condition A.
- 3/ The limiting terms "min" (minimum) and "max" (maximum) shall be considered to apply to magnitudes only. Negative current shall be defined as conventional current flow out of a device terminal.
- 4/ This parameter is not tested post-irradiation.
- 5/ For proper operation the positive supply must be sequenced ON before the negative supply.

STANDARD MICROCIRCUIT DRAWING DEFENSE SUPPLY CENTER COLUMBUS COLUMBUS, OHIO 43218-3990	SIZE A		5962-93258
		REVISION LEVEL F	SHEET 6

Device type	01	
Case outlines	C and D	2
Terminal number	Terminal symbol	
1	OUTPUT A	NC
2	-INPUT A	OUTPUT A
3	+INPUT A	-INPUT A
4	+V _{CC}	+INPUT A
5	+INPUT B	NC
6	-INPUT B	+V _{CC}
7	OUTPUT B	NC
8	OUTPUT C	+INPUT B
9	-INPUT C	-INPUT B
10	+INPUT C	OUTPUT B
11	-V _{CC}	NC
12	+INPUT D	OUTPUT C
13	-INPUT D	-INPUT C
14	OUTPUT D	+INPUT C
15	----	NC
16	----	-V _{CC}
17	----	NC
18	----	+INPUT D
19	----	-INPUT D
20	----	OUTPUT D

NC = No connection

FIGURE 1. Terminal connections.

STANDARD MICROCIRCUIT DRAWING DEFENSE SUPPLY CENTER COLUMBUS COLUMBUS, OHIO 43218-3990	SIZE A		5962-93258
		REVISION LEVEL F	SHEET 7

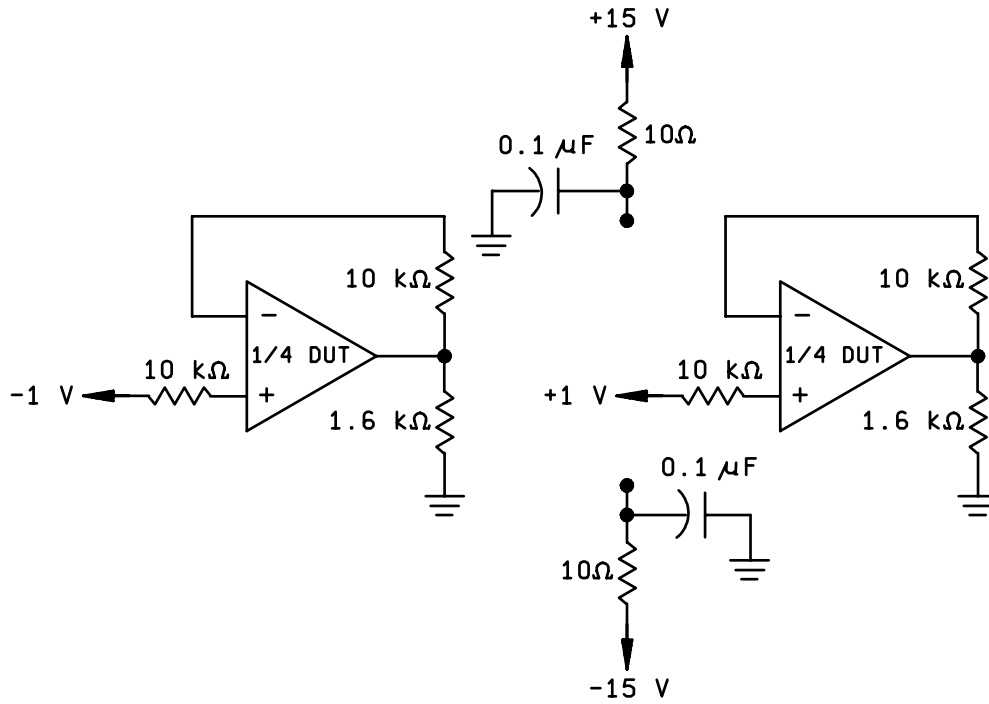

FIGURE 2. Radiation exposure circuit.

STANDARD MICROCIRCUIT DRAWING DEFENSE SUPPLY CENTER COLUMBUS COLUMBUS, OHIO 43218-3990	SIZE A		5962-93258
		REVISION LEVEL F	SHEET 8

4. VERIFICATION

4.1 Sampling and inspection. For device classes Q and V, sampling and inspection procedures shall be in accordance with MIL-PRF-38535 or as modified in the device manufacturer's Quality Management (QM) plan. The modification in the QM plan shall not affect the form, fit, or function as described herein. For device class M, sampling and inspection procedures shall be in accordance with MIL-PRF-38535, appendix A.

4.2 Screening. For device classes Q and V, screening shall be in accordance with MIL-PRF-38535, and shall be conducted on all devices prior to qualification and technology conformance inspection. For device class M, screening shall be in accordance with method 5004 of MIL-STD-883, and shall be conducted on all devices prior to quality conformance inspection.

4.2.1 Additional criteria for device class M.

- a. Burn-in test, method 1015 of MIL-STD-883.
 - (1) Test condition B. The test circuit shall be maintained by the manufacturer under document revision level control and shall be made available to the preparing or acquiring activity upon request. The test circuit shall specify the inputs, outputs, biases, and power dissipation, as applicable, in accordance with the intent specified in method 1015.
 - (2) $T_A = +125^{\circ}\text{C}$, minimum.
- b. Interim and final electrical test parameters shall be as specified in table IIA herein.

4.2.2 Additional criteria for device classes Q and V.

- a. The burn-in test duration, test condition and test temperature, or approved alternatives shall be as specified in the device manufacturer's QM plan in accordance with MIL-PRF-38535. The burn-in test circuit shall be maintained under document revision level control of the device manufacturer's Technology Review Board (TRB) in accordance with MIL-PRF-38535 and shall be made available to the acquiring or preparing activity upon request. The test circuit shall specify the inputs, outputs, biases, and power dissipation, as applicable, in accordance with the intent specified in method 1015 of MIL-STD-883.
- b. Interim and final electrical test parameters shall be as specified in table IIA herein.
- c. Additional screening for device class V beyond the requirements of device class Q shall be as specified in MIL-PRF-38535, appendix B.

4.3 Qualification inspection for device classes Q and V. Qualification inspection for device classes Q and V shall be in accordance with MIL-PRF-38535. Inspections to be performed shall be those specified in MIL-PRF-38535 and herein for groups A, B, C, D, and E inspections (see 4.4.1 through 4.4.4).

4.4 Conformance inspection. Technology conformance inspection for classes Q and V shall be in accordance with MIL-PRF-38535 including groups A, B, C, D, and E inspections and as specified herein. Quality conformance inspection for device class M shall be in accordance with MIL-PRF-38535, appendix A and as specified herein. Inspections to be performed for device class M shall be those specified in method 5005 of MIL-STD-883 and herein for groups A, B, C, D, and E inspections (see 4.4.1 through 4.4.4).

4.4.1 Group A inspection.

- a. Tests shall be as specified in table IIA herein.
- b. Subgroups 10 and 11 in table I, method 5005 of MIL-STD-883 shall be omitted.

STANDARD MICROCIRCUIT DRAWING DEFENSE SUPPLY CENTER COLUMBUS COLUMBUS, OHIO 43218-3990	SIZE A		5962-93258
		REVISION LEVEL F	SHEET 9

TABLE IIA. Electrical test requirements.

Test requirements	Subgroups (in accordance with MIL-STD-883, method 5005, table I)	Subgroups (in accordance with MIL-PRF-38535, table III)	
	Device class M	Device class Q	Device class V
Interim electrical parameters (see 4.2)	1	1	1
Final electrical parameters (see 4.2)	1,2,3,4,5,6 <u>1/</u>	1,2,3,4,5,6 <u>1/</u>	1,2,3,4, <u>1/ 2/</u> 5,6
Group A test requirements (see 4.4)	1,2,3,4,5,6,7,8,9	1,2,3,4,5, 6,7,8,9	1,2,3,4,5, 6,7,8,9
Group C end-point electrical parameters (see 4.4)	1	1	1 <u>2/</u>
Group D end-point electrical parameters (see 4.4)	1	1	1
Group E end-point electrical parameters (see 4.4)	----	----	1, 4

1/ PDA applies to subgroup 1. Exclude delta from PDA.

2/ See table IIB for delta measurement parameters.

Table IIB. 240 hour burn-in and group C end-point electrical parameters.

Parameter	Device type	End-Point		Delta	Unit
		Min	Max	Max	
V _{IO}	01		0.5	±0.2	mV
I _{IB}	01		600	±250	nA

4.4.2 Group C inspection. The group C inspection end-point electrical parameters shall be as specified in table IIA herein.

4.4.2.1 Additional criteria for device class M. Steady-state life test conditions, method 1005 of MIL-STD-883:

- a. Test condition B. The test circuit shall be maintained by the manufacturer under document revision level control and shall be made available to the preparing or acquiring activity upon request. The test circuit shall specify the inputs, outputs, biases, and power dissipation, as applicable, in accordance with the intent specified in method 1005 of MIL-STD-883.
- b. T_A = +125°C, minimum.
- c. Test duration: 1,000 hours, except as permitted by method 1005 of MIL-STD-883.

4.4.2.2 Additional criteria for device classes Q and V. The steady-state life test duration, test condition and test temperature, or approved alternatives shall be as specified in the device manufacturer's QM plan in accordance with MIL-PRF-38535. The test circuit shall be maintained under document revision level control by the device manufacturer's TRB in accordance with MIL-PRF-38535 and shall be made available to the acquiring or preparing activity upon request. The test circuit shall specify the inputs, outputs, biases, and power dissipation, as applicable, in accordance with the intent specified in method 1005 of MIL-STD-883.

4.4.3 Group D inspection. The group D inspection end-point electrical parameters shall be as specified in table IIA herein.

STANDARD MICROCIRCUIT DRAWING DEFENSE SUPPLY CENTER COLUMBUS COLUMBUS, OHIO 43218-3990	SIZE A		5962-93258
		REVISION LEVEL F	SHEET 10

4.4.4 Group E inspection. Group E inspection is required only for parts intended to be marked as radiation hardness assured (see 3.5 herein). RHA levels for device classes M, Q, and V shall be as specified in MIL-PRF-38535. End-point electrical parameters shall be as specified in table IIA herein.

4.4.4.1 Total dose irradiation testing. Total dose irradiation testing shall be performed in accordance with MIL-STD-883 method 1019 condition A and as specified herein.

5. PACKAGING

5.1 Packaging requirements. The requirements for packaging shall be in accordance with MIL-PRF-38535 for device classes Q and V or MIL-PRF-38535, appendix A for device class M.

6. NOTES

6.1 Intended use. Microcircuits conforming to this drawing are intended for use for Government microcircuit applications (original equipment), design applications, and logistics purposes.

6.1.1 Replaceability. Microcircuits covered by this drawing will replace the same generic device covered by a contractor prepared specification or drawing.

6.1.2 Substitutability. Device class Q devices will replace device class M devices.

6.2 Configuration control of SMD's. All proposed changes to existing SMD's will be coordinated with the users of record for the individual documents. This coordination will be accomplished using DD Form 1692, Engineering Change Proposal.

6.3 Record of users. Military and industrial users should inform Defense Supply Center Columbus (DSCC) when a system application requires configuration control and which SMD's are applicable to that system. DSCC will maintain a record of users and this list will be used for coordination and distribution of changes to the drawings. Users of drawings covering microelectronic devices (FSC 5962) should contact DSCC-VA, telephone (614) 692-0544.

6.4 Comments. Comments on this drawing should be directed to DSCC-VA , Columbus, Ohio 43218-3990, or telephone (614) 692-0547.

6.5 Abbreviations, symbols, and definitions. The abbreviations, symbols, and definitions used herein are defined in MIL-PRF-38535 and MIL-HDBK-1331.

6.6 Sources of supply.

6.6.1 Sources of supply for device classes Q and V. Sources of supply for device classes Q and V are listed in QML-38535. The vendors listed in QML-38535 have submitted a certificate of compliance (see 3.6 herein) to DSCC-VA and have agreed to this drawing.

6.6.2 Approved sources of supply for device class M. Approved sources of supply for class M are listed in MIL-HDBK-103. The vendors listed in MIL-HDBK-103 have agreed to this drawing and a certificate of compliance (see 3.6 herein) has been submitted to and accepted by DSCC-VA.

STANDARD MICROCIRCUIT DRAWING DEFENSE SUPPLY CENTER COLUMBUS COLUMBUS, OHIO 43218-3990	SIZE A		5962-93258
		REVISION LEVEL F	SHEET 11

STANDARD MICROCIRCUIT DRAWING BULLETIN

DATE: 05-09-07

Approved sources of supply for SMD 5962-93258 are listed below for immediate acquisition information only and shall be added to MIL-HDBK-103 and QML-38535 during the next revision. MIL-HDBK-103 and QML-38535 will be revised to include the addition or deletion of sources. The vendors listed below have agreed to this drawing and a certificate of compliance has been submitted to and accepted by DSCC-VA. This information bulletin is superseded by the next dated revision of MIL-HDBK-103 and QML-38535. DSCC maintains an online database of all current sources of supply at <http://www.dscclia.mil/Programs/Smcr/>.

Standard microcircuit drawing PIN <u>1/</u>	Vendor CAGE number	Vendor similar PIN <u>2/</u>
5962-9325801MCA	24355	OP467AY/883
5962-9325801M2A	24355	OP467ARC/883
5962-9325801VCA	24355	OP467AY/QMLV
5962-9325801V2A	24355	OP467ARC/QMLV
5962R9325801VDA	24355	OP467AM/QMLR
5962R9325801VCA	24355	OP467AY/QMLR

1/ The lead finish shown for each PIN representing a hermetic package is the most readily available from the manufacturer listed for that part. If the desired lead finish is not listed contact the vendor to determine its availability.

2/ **Caution.** Do not use this number for item acquisition. Items acquired to this number may not satisfy the performance requirements of this drawing.

Vendor CAGE
number

24355

Vendor name
and address

Analog Devices
RT 1 Industrial Park
PO Box 9106
Norwood, MA 02062
Point of contact: 1500 Space Park Drive
P.O. Box 58020
Santa Clara, CA 95052-8020

The information contained herein is disseminated for convenience only and the Government assumes no liability whatsoever for any inaccuracies in the information bulletin.