

## E-BAND LOW NOISE DOWNCONVERTER SIP 71 - 76 GHz

### Typical Applications

The HMC8326LG is ideal for:

- E-Band Communication Systems
- High Capacity Wireless Backhaul
- Test & Measurement

### Functional Diagram

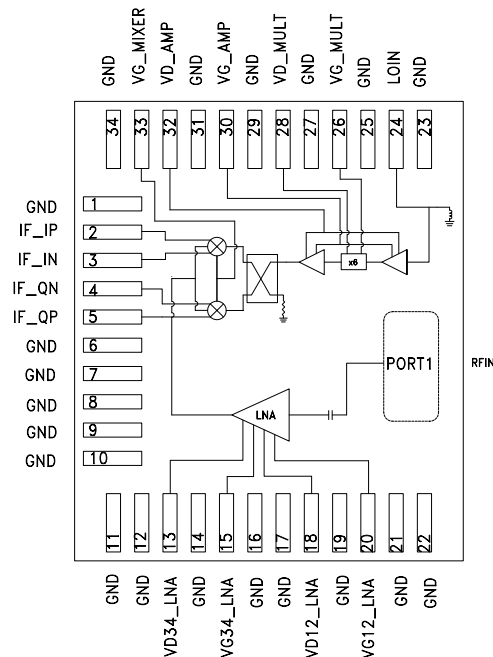

### Features

- Conversion Gain: 12 dB typical
- Image Rejection: 30 dBc typical
- Noise Figure: 6 dB typical
- Input Third-Order Intercept (IP3): 1 dBm typical
- Input Power for P1dB Compression: -9 dBm typical
- Fully Integrated In Surface Mount 34 Lead 13 mm x 11 mm Package

### General Description

The HMC8326LG is a fully integrated System In Package (SiP) in-phase/quadrature (I/Q) downconverter that operates between an RF input frequency range of 71 GHz to 76 GHz and an IF output frequency range of DC to 2 GHz. This device provides a small signal conversion gain of 8 to 13 dB with 30 dBc of image rejection. The HMC8326LG utilizes a low noise amplifier followed by an image rejection mixer which is driven by a 6x LO multiplier. Differential I and Q mixer outputs are provided for direct conversion applications. Alternatively, the outputs can be combined using an external 90° hybrid and two external 180° hybrids for single-ended applications.

**Electrical Specifications,  $T_A = -40^\circ\text{C}$  to  $+85^\circ\text{C}$ , IF = 1000 MHz, LO = 4 dBm, VD\_LNA = 3 V, VD\_AMP = 4 V, VD\_MULT = 1.5 V, VG\_MIXER = -1 V [1]**

Parameter	Min.	Typ. (25°C)	Max.	Units
RF Frequency Range	71		76	GHz
LO Frequency Range	11.5		13	GHz
IF Frequency Range	0		2	GHz
LO Input Level Range	0		8	dBm
Gain Flatness		2		dB
Conversion Gain		12		dB
Image Rejection		30		dBc
Input Power for 1 dB Compression (P1dB)		-9		dBm
Input Third-Order Intercept (IP3)		1		dBm
Input Second-Order Intercept (IP2)		32		dBm
6x LO Leakage at the RF Input Port (RFIN)		-55		dBm
I/Q Phase Balance [2]		5		degrees
I/Q Amplitude Balance [2]		0.2		dB
Noise Figure		6		dB

[1] Measurements performed as downconverter with lower sideband selected and two external 180° hybrids followed by one external 90° hybrid at the IF ports, unless otherwise noted.

[2] Measurements performed without external hybrids.

## E-BAND LOW NOISE DOWNCONVERTER SIP 71 - 76 GHz

**Electrical Specifications,  $T_A = -40^\circ\text{C}$  to  $+85^\circ\text{C}$ ,  $IF = 1000\text{ MHz}$ ,  $LO = 4\text{ dBm}$ ,  
 $VD_{LNA} = 3\text{ V}$ ,  $VD_{AMP} = 4\text{ V}$ ,  $VD_{MULT} = 1.5\text{ V}$ ,  $VG_{MIXER} = -1\text{ V}$  [1]**

Parameter	Min.	Typ. (25°C)	Max.	Units
RF Port Return Loss		14		dB
DC Power Dissipation		1.0		W
Input Waveguide port		WR-12		
Baseband Output Port Impedance (differential)		100		Ohm
Baseband Output Port Return Loss [2]		14		dB
LO Input Port Impedance		50		Ohm
LO Input Port Return Loss		13		dB
VG for the LNA	-2		0	V
VD for the LNA		3		V
VD for the Multiplier (VD_MULT)		1.5		V
VG for the Multiplier (VG_MULT)	-2		0	V
VG for the Mixer (VG_MIXER)	-2		0	V

[1] Measurements performed as downconverter with lower sideband selected and two external  $180^\circ$  hybrids followed by one external  $90^\circ$  hybrid at the IF ports, unless otherwise noted.