

DESCRIPTION

Demonstration circuit 704 is a dual output regulator based on the LT3023 IC, which consists of two identical LDO linear regulators. The DC704 has an input voltage range of 2.3V to 20V, and either output is capable of delivering up to 100mA of output current. The DC supply current is typically only 20uA (per channel) at no load. The LT3023 comes in a small 10-pin DFN package, which has an exposed pad on the bottom-side of the IC for better thermal performance. DC704 comes installed with ceramic capaci-

tors, because of the LT3023 ability of maintaining stability with ceramic output capacitors. There are ceramic bypass capacitors on each output for extra low noise performance. These features make the DC704 an ideal circuit for use in battery-powered, hand-held applications or noise sensitive applications.

Design files for this circuit are available. Call the LTC Factory.

QUICK START PROCEDURE

DC704 is easy to set up to evaluate the performance of the LT3023. Refer to Figure 1 for proper measurement equipment setup and follow the procedure outlined below for proper operation.

1. Connect the input power supply to the VIN and GND terminals. Connect the loads between the VOUT and GND terminals.
2. Before proceeding to operation, insert jumpers JP3 and JP4 into the OFF positions, jumpers JP1 and JP2 into the voltage options of choice (2.5V, 3.3V, and 5V).
3. Apply 6.5V at VIN. Measure both VOUT1 and VOUT2; they should read 0V.
4. Turn on VOUT1 and VOUT2 by moving jumpers JP3 and JP4 from the OFF position to the ON position. Both output voltages should be within a tolerance of +/- 2%.
5. Vary the input voltage from 6.5V to 20V. Both output voltages should be within +/- 3.3% tolerance.

6. Vary each load current from 0 to 100mA. Both output voltages should be within a tolerance of +/- 4%.
7. Observe both output voltages AC-coupled; they should measure noise voltages of less than 2mVAC each. Refer to Figure 2 for proper measurement technique.
8. When finished, move jumpers JP3 and JP4 to the OFF position and disconnect the power.

Warning - if long leads are used to power the demo circuit, the input voltage at the part could "ring", which could affect the operation of the circuit or even exceed the maximum voltage rating of the IC. To eliminate the ringing, insert a small tantalum capacitor (for instance, an AVX part # TAJW106M025R) on the pads between the input power and return terminals on the bottom of the demo board. The (greater) ESR of the tantalum will dampen the (possible) ringing voltage due to the use of long input leads. On a normal, typical PCB, with short traces, the capacitor is not needed.

QUICK START GUIDE FOR DEMONSTRATION CIRCUIT 704

DUAL OUTPUT LOW NOISE LDO REGULATORS

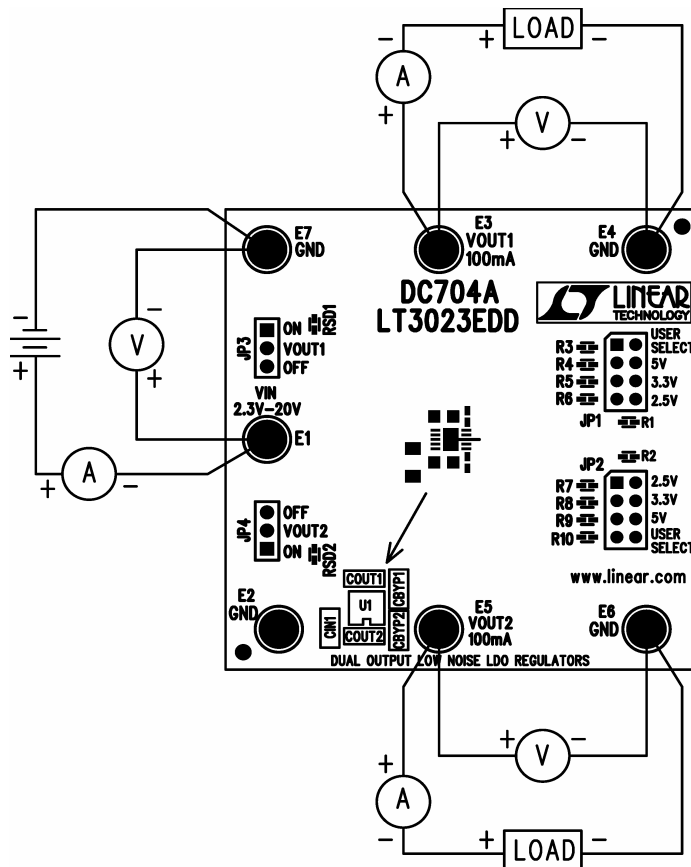

Figure1. Proper Measurement Equipment Setup

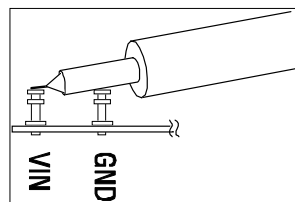
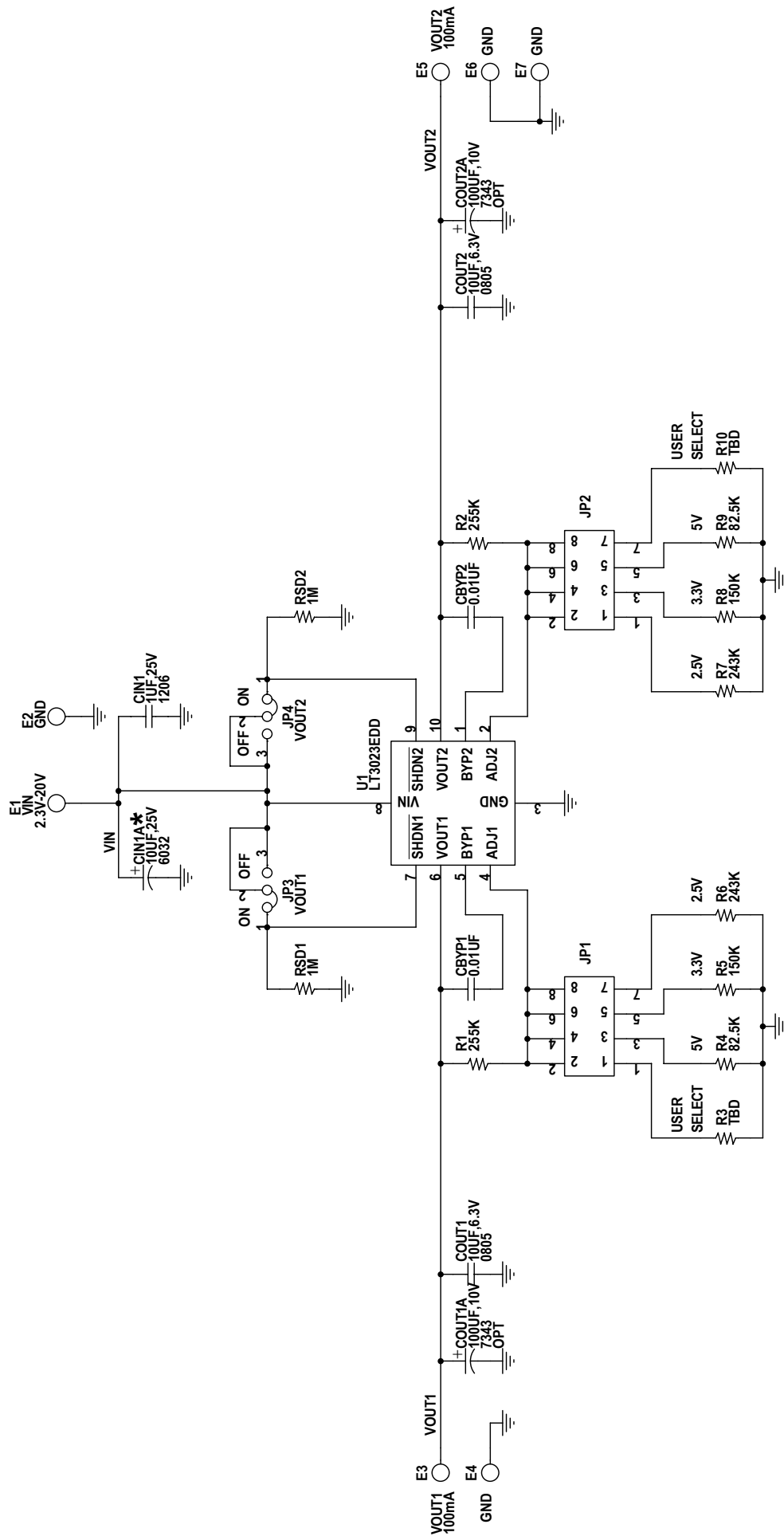

Figure 2. Measuring Input or Output Ripple



NOTES: UNLESS OTHERWISE SPECIFIED

1. ALL RESISTORS ARE IN OHMS, 0402.
ALL CAPACITORS ARE IN MICROFARADS, 0402.
2. INSTALL SHUNTS ON JP1 AND JP2 PIN 3 AND 4; JP3 AND JP4 PIN 1 AND 2.

*** CIN1A IS AN OPTIONAL CAPACITOR. IT WAS INSERTED ON THE DC704A TO DAMPEN THE (POSSIBLE) RINGING VOLTAGE DUE TO THE USE OF LONG INPUT LEADS. ON A NORMAL, TYPICAL PCB, WITH SHORT TRACES, CIN1A IS NOT NEEDED.**

CUSTOMER NOTICE

LINEAR TECHNOLOGY HAS MADE A BEST EFFORT TO DESIGN A CIRCUIT THAT MEETS CUSTOMER-SUPPLIED SPECIFICATIONS; HOWEVER, IT REMAINS THE CUSTOMER'S RESPONSIBILITY TO VERIFY PROPER AND RELIABLE OPERATION IN THE ACTUAL APPLICATION. COMPONENT SUBSTITUTION AND PRINTED CIRCUIT BOARD LAYOUT MAY SIGNIFICANTLY AFFECT CIRCUIT PERFORMANCE OR RELIABILITY. CONTACT LINEAR TECHNOLOGY APPLICATIONS ENGINEERING FOR ASSISTANCE. THIS CIRCUIT IS PROPRIETARY TO LINEAR TECHNOLOGY AND SUPPLIED FOR USE WITH LINEAR TECHNOLOGY PARTS.

CONTRACT NO.	
APPROVALS	
DRAWN: KIM T.	
CHECKED:	
APPROVED:	
ENGINEER: TOM G.	
DESIGNER:	

1630 McCarthy Blvd.
Milpitas, CA 95035
Phone: (408)432-1900
Fax: (408)434-0507
LTC Confidential-For Customer Use Only

TITLE: SCHEMATIC

DUAL OUTPUT LOW NOISE LDO REGULATORS

SIZE DWG NO. **DC704A * LT3023EDD** REV **A**

DATE: Monday, January 05, 2004 SHEET 1 OF 1

Linear Technology Corporation

LT3023EDD

DUAL OUTPUT LOW NOISE LDO REGULATORS
 ENG: TOM GROSS (23-30)

BILL OF MATERIALS

DC704A

6/20/2005

10:06 AM

Item	Qty	Reference	Part Description	Manufacture / Part #
1	2	CBYP2,CBYP1	CAP., X7R, 0.01UF 16V, 20%, 0402	AVX, 0402YC103MAT
2	1	CIN1	CAP., X7R, 1UF 25V, 20%, 1206	AVX, 12063C105MAT
3	1	CIN1A	CAP., TANT 10UF 25V, 20%, 6032	AVX, TAJW106M025R
4	0	COUT1A,COUT2A	CAP., TANT 100UF 10V, 7343	AVX, TPSD107M010R0100 OPT
5	2	COUT2,COUT1	CAP., X5R, 10UF 6.3V, 20%, 0805	TAIYO YUDEN, JMK212BJ106MG-T
6	7	E1-E7	TESTPOINT, TURRET, .094"	MILL-MAX, 2501-2
7	2	JP1,JP2	JMP, 2X4, .079CC, HD2X4-079	COMM-CON, 2202S-08-G2
8	2	JP3,JP4	HEADER, 3PIN 1 ROW .079CC	COMM-CON, 2802S-03-G1
9	4	SHUNTS FOR JP1-JP4	SHUNT, .079" CENTER	COMM-CON CCIJ2MM-138G
10	2	RSD2,RSD1	RES., CHIP 1M 1/16W 5%,0402	AAC, CR05-105JM
11	2	R1,R2	RES., CHIP 255K 1/16W 1%,0402	AAC, CR05-2553FM
12	0	R10,R3	RES., CHIP, 0402	TBD
13	2	R9,R4	RES., CHIP 82.5K 1/16W 1%,0402	AAC, CR05-8252FM
14	2	R5,R8	RES., CHIP 150K 1/16W 1%,0402	AAC, CR05-1503FM
15	2	R7,R6	RES., CHIP 243K 1/16W 1%,0402	AAC, CR05-2433FM
16	1	U1	I.C., LT3023EDD,DFN10DD	LINEAR TECH., LT3023EDD