

## Edge Drive Jog Encoders

Type: **EVQWK**

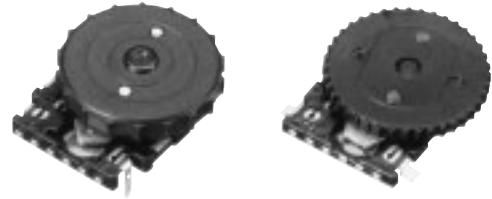

### ■ Features

- Tactile rotary operation and push operation
- Reflow soldering type available
- Anti-electrostatic measures available

### ■ Recommended Applications

- Memory paging and transmitting
- Menu selection and input for Portable Electronic Equipment

### ■ Explanation of Part Numbers

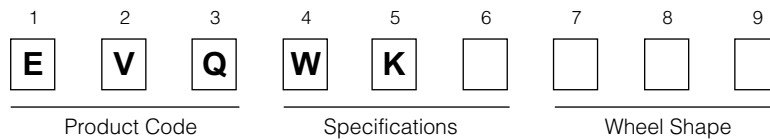

### ■ Specifications

Mechanical	Encoder	Detents	15 points
		Rotation Torque	1 mN·m to 10 mN·m
	Push-on Switch	Travel	0.3 mm (Thin-Type : 0.2 mm)
		Operating Force	4.5 N±1.5 N
Electrical	Encoder	Resolution	15 pulses/360 °
		Output Signals	2-Phases (A and B)
		Contact Resistance	1 Ω max.
	Push-on Switch	Contact Resistance	100 mΩ
Endurance	Encoder	Rotation Life	100000 cycles min.
	Push-on Switch	Operating Life	
Minimum Quantity/Packing Unit			100 pcs. (Tray Pack)
			400 pcs. Embossed Taping (Reel Pack)
Quantity/Carton			1000 pcs.
			1600 pcs.

Design and specifications are each subject to change without notice. Ask factory for the current technical specifications before purchase and/or use. Should a safety concern arise regarding this product, please be sure to contact us immediately.

## ■ Dimensions in mm (not to scale)

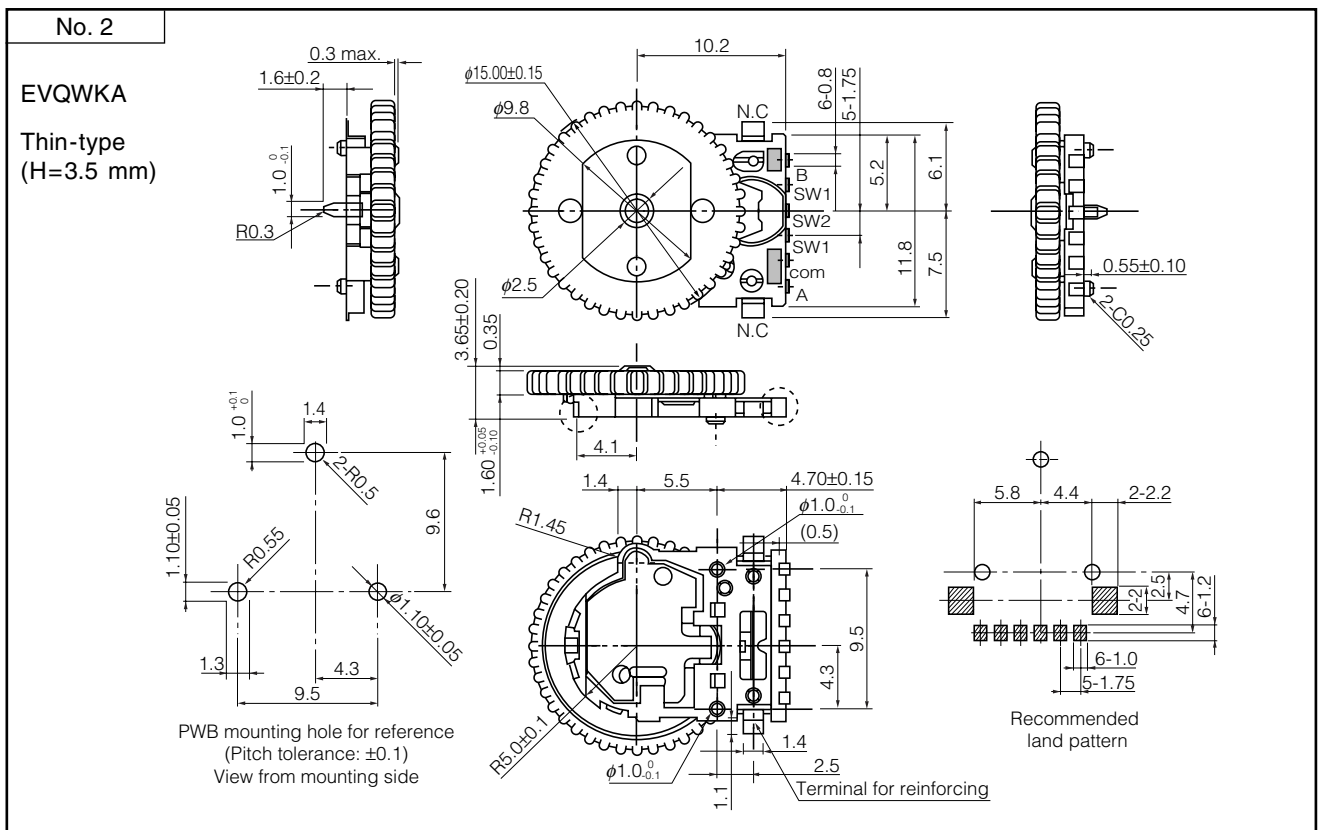
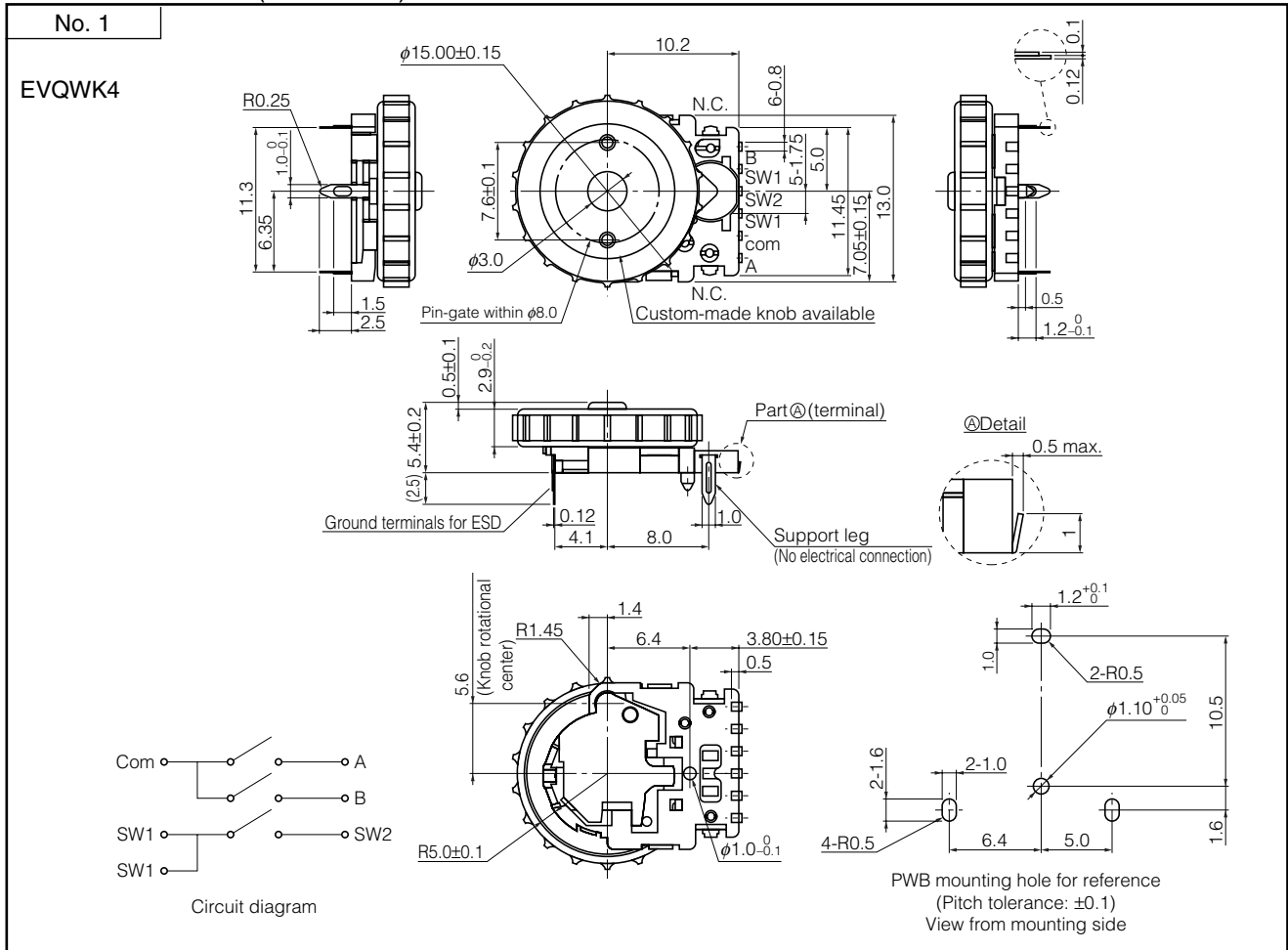

Design and specifications are each subject to change without notice. Ask factory for the current technical specifications before purchase and/or use. Should a safety concern arise regarding this product, please be sure to contact us immediately.