

TrueTouch® Multi-Touch All-Points Touchscreen Controller Datasheet

Features

- Multi-touch capacitive touchscreen controller
 - 32-bit ARM Cortex™ CPU
 - Register configurable
 - Noise suppression technologies for battery charger and display
 - Effective 28-V drive for higher signal-to-noise ratio (SNR)
 - ChargerArmor™ for charger noise immunity
 - External display synchronization
 - Water rejection and wet-finger tracking using DualSense™
 - Multi-touch glove with automatic mode switching
 - 10 fingers with thin glove (≤1-mm thick)
 - 2 fingers with thick glove (≤5-mm thick)
 - Fingernail tracking
 - Large object rejection
 - Automatic baseline tracking to environmental changes
 - Low-power look-for-touch mode
 - Field upgrades via bootloader
 - Android™ driver support
 - Cypress Manufacturing Test Kit (MTK)
 - Touchscreen sensor self-test and Panel ID reporting
- System performance (configuration dependent)
 - Screen sizes up to 5.0-inch diagonal
 - 4.8-mm sensor pitch, 16:9 aspect ratio
 - Up to 36 sense pins
 - 299 intersections (23 × 13)
 - Reports up to 10 fingers
 - Small finger support down to 4 mm
 - Large finger support up to 30 mm
 - Refresh rate up to 300 Hz; other rates configurable
 - TX frequency up to 500 kHz
 - Fast first-touch response (≤13 ms)
 - Charger noise immunity
 - Immunity up to 35 peak-to-peak voltage (V_{PP})
 - Immunity to AT&T Zero charger
- Power (configuration dependent)
 - 1.71- to 5.5-V digital and I/O supply
 - 2.65- to 5.5-V analog supply
 - 6.75-mW average power
 - 4.5-μW typical deep-sleep power
- Sensor and system design (configuration dependent)
 - Supports a variety of touchscreen sensors and stackups
 - Manhattan, diamond, and Single Layer Independent Multi-touch (SLIM®) patterns
 - Sensor-on-lens (SOL)
 - On-cell touch integrated display modules
 - Plastic (PET) and glass sensor substrates
 - LCD and AMOLED displays
 - Single-layer flexible printed circuit (FPC) routing enabled by flexible TX/RX configurations
- Communication Interface
 - I²C slave at all standard bit rates
 - 100 kbps, 400 kbps, 1 Mbps, and 3.4 Mbps
 - SPI slave bit rate up to 10 Mbps
- Package options
 - 44-pin 5 × 5 × 0.6-mm QFN (0.35-mm lead pitch)
 - 48-pin 6 × 6 × 0.6-mm QFN (0.4-mm lead pitch)

Ordering Information

Table 1 lists the CYTMA445 TrueTouch touchscreen controllers. For information on other TrueTouch® families, visit <http://www.cypress.com/truetouch>.

Table 1. Device Ordering Information [1]

Device Part Number		Base Features					Glove	Package
Family	Part Number	Sense Pins	Typ Screen Size (inches) ^[2]	Max Fingers	TX Slew Rate Control	Improved ESD Performance		
Water Rejection (DualSense)	CYTMA445-48LQI36AE(T)	36	5.0	10	–	–	✓	48-Pin QFN
Custom Reserved for Kits	CYTMA445-44LQI33ZZ(T)	33	4.5	10	–	–	✓	44-Pin QFN
Base	CYTMA445-44LQI28AAA(T)	28	3.9	10	✓	✓	–	44-Pin QFN
	CYTMA445-44LQI33AAA(T)	33	4.5	10	✓	✓	–	44-Pin QFN
	CYTMA445-48LQI36AAA(T)	36	5.0	10	✓	✓	–	48-Pin QFN
Water Rejection (DualSense)	CYTMA445-44LQI33ABA(T)	33	4.5	10	✓	✓	–	44-Pin QFN
	CYTMA445-48LQI36ABA(T)	36	5.0	10	✓	✓	–	48-Pin QFN
	CYTMA445-44LQI33ACA(T)	33	4.5	10	✓	✓	–	44-Pin QFN
	CYTMA445-48LQI36ACA(T)	36	5.0	10	✓	✓	–	48-Pin QFN
	CYTMA445-44LQI33AEA(T)	33	4.5	10	✓	✓	✓	44-Pin QFN
	CYTMA445-48LQI36AEA(T)	36	5.0	10	✓	✓	✓	48-Pin QFN
Custom Reserved for Kits	CYTMA445-44LQI33ZZA(T)	33	4.5	10	✓	✓	✓	44-Pin QFN
	CYTMA445-48LQI36ZZA(T)	36	5.0	10	✓	✓	✓	48-Pin QFN

Ordering Code Definitions

CYTMA 445 - ##LQI ## · XX (A) · (T)

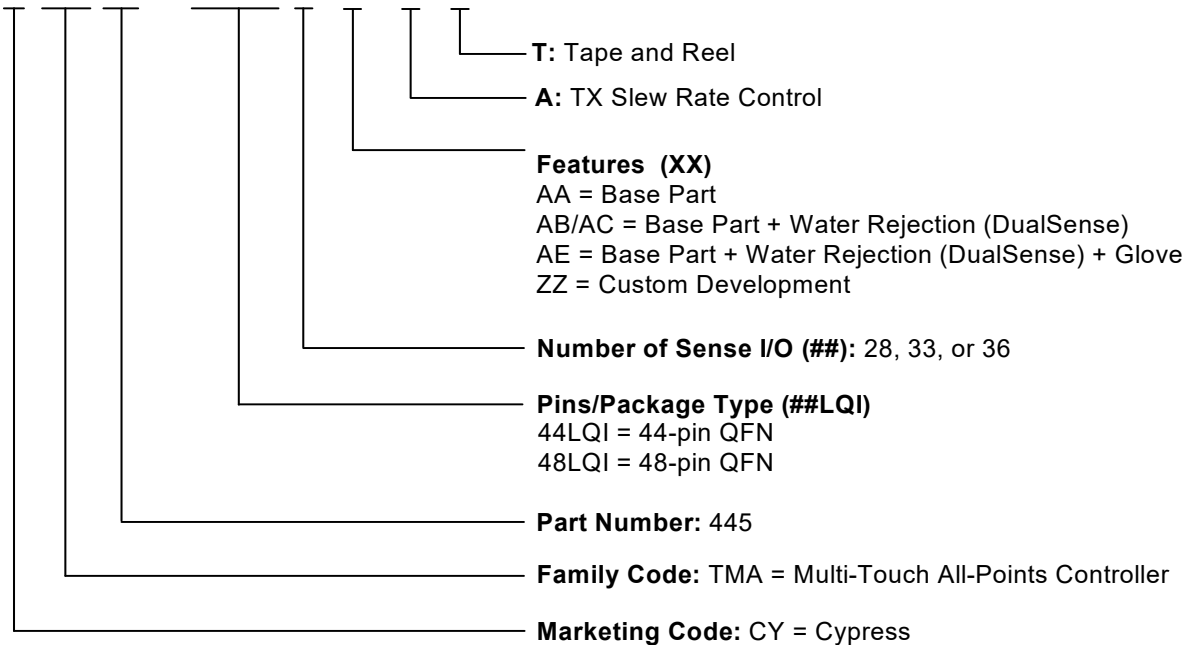

Notes

- All devices have the following base features: 10-V TX, ChargerArmor, CapSense buttons, Large Object Detection and Rejection, and Grip Suppression.
- 4.7-mm pitch for screen sizes up to 4.9-inch diagonal, 4.8-mm pitch for 5.0-inch diagonal screen size, 16:9 aspect ratio. Larger screen sizes can be supported with a larger pitch.

Document History Page

Document Title: CYTMA445, TrueTouch® Multi-Touch All-Points Touchscreen Controller Datasheet				
Document Number: 001-90907				
Revision	ECN	Orig. of Change	Submission Date	Description of Change
**	4267426	SWU	02/19/2014	New data sheet.
*A	4379995	SWU	05/14/2014	Updated Features: Replaced "Refresh rate up to 250 Hz" with "Refresh rate up to 300 Hz". Updated Ordering Information: Updated part numbers. Updated Ordering Code Definitions (Removed 24 under "Number of Sense I/O").
*B	4392605	SWU	05/28/2014	Updated Features: Removed "Face detection with grip suppression" under "Multi-touch capacitive touchscreen controller". Replaced "6.1-mW average power" with "6.75-mW average power" under "Power (configuration dependent)". Updated Ordering Information: Updated part numbers.
*C	4466944	SWU	08/08/2014	Updated Document Title to read as "CYTMA445, TrueTouch® Multi-Touch All-Points Touchscreen Controller Datasheet". Completing Sunset Review.
*D	5139587	ELG	02/18/2016	Updated Ordering Information: Updated part numbers. Updated copyright information. Completing Sunset Review.
*E	6434214	ELG	01/08/2019	Updated to new template. Completing Sunset Review.

Sales, Solutions, and Legal Information

Worldwide Sales and Design Support

Cypress maintains a worldwide network of offices, solution centers, manufacturer's representatives, and distributors. To find the office closest to you, visit us at [Cypress Locations](#).

Products

Arm® Cortex® Microcontrollers	cypress.com/arm
Automotive	cypress.com/automotive
Clocks & Buffers	cypress.com/clocks
Interface	cypress.com/interface
Internet of Things	cypress.com/iot
Memory	cypress.com/memory
Microcontrollers	cypress.com/mcu
PSoC	cypress.com/psoc
Power Management ICs	cypress.com/pmic
Touch Sensing	cypress.com/touch
USB Controllers	cypress.com/usb
Wireless Connectivity	cypress.com/wireless

PSoC® Solutions

[PSoC 1](#) | [PSoC 3](#) | [PSoC 4](#) | [PSoC 5LP](#) | [PSoC 6 MCU](#)

Cypress Developer Community

[Community](#) | [Projects](#) | [Video](#) | [Blogs](#) | [Training](#) | [Components](#)

Technical Support

cypress.com/support

© Cypress Semiconductor Corporation 2014–2019. This document is the property of Cypress Semiconductor Corporation and its subsidiaries, including Spansion LLC ("Cypress"). This document, including any software or firmware included or referenced in this document ("Software"), is owned by Cypress under the intellectual property laws and treaties of the United States and other countries worldwide. Cypress reserves all rights under such laws and treaties and does not, except as specifically stated in this paragraph, grant any license under its patents, copyrights, trademarks, or other intellectual property rights. If the Software is not accompanied by a license agreement and you do not otherwise have a written agreement with Cypress governing the use of the Software, then Cypress hereby grants you a personal, non-exclusive, nontransferable license (without the right to sublicense) (1) under its copyright rights in the Software (a) for Software provided in source code form, to modify and reproduce the Software solely for use with Cypress hardware products, only internally within your organization, and (b) to distribute the Software in binary code form externally to end users (either directly or indirectly through resellers and distributors), solely for use on Cypress hardware product units, and (2) under those claims of Cypress's patents that are infringed by the Software (as provided by Cypress, unmodified) to make, use, distribute, and import the Software solely for use with Cypress hardware products. Any other use, reproduction, modification, translation, or compilation of the Software is prohibited.

TO THE EXTENT PERMITTED BY APPLICABLE LAW, CYPRESS MAKES NO WARRANTY OF ANY KIND, EXPRESS OR IMPLIED, WITH REGARD TO THIS DOCUMENT OR ANY SOFTWARE OR ACCOMPANYING HARDWARE, INCLUDING, BUT NOT LIMITED TO, THE IMPLIED WARRANTIES OF MERCHANTABILITY AND FITNESS FOR A PARTICULAR PURPOSE. No computing device can be absolutely secure. Therefore, despite security measures implemented in Cypress hardware or software products, Cypress does not assume any liability arising out of any security breach, such as unauthorized access to or use of a Cypress product. In addition, the products described in these materials may contain design defects or errors known as errata which may cause the product to deviate from published specifications. To the extent permitted by applicable law, Cypress reserves the right to make changes to this document without further notice. Cypress does not assume any liability arising out of the application or use of any product or circuit described in this document. Any information provided in this document, including any sample design information or programming code, is provided only for reference purposes. It is the responsibility of the user of this document to properly design, program, and test the functionality and safety of any application made of this information and any resulting product. Cypress products are not designed, intended, or authorized for use as critical components in systems designed or intended for the operation of weapons, weapons systems, nuclear installations, life-support devices or systems, other medical devices or systems (including resuscitation equipment and surgical implants), pollution control or hazardous substances management, or other uses where the failure of the device or system could cause personal injury, death, or property damage ("Unintended Uses"). A critical component is any component of a device or system whose failure to perform can be reasonably expected to cause the failure of the device or system, or to affect its safety or effectiveness. Cypress is not liable, in whole or in part, and you shall and hereby do release Cypress from any claim, damage, or other liability arising from or related to all Unintended Uses of Cypress products. You shall indemnify and hold Cypress harmless from and against all claims, costs, damages, and other liabilities, including claims for personal injury or death, arising from or related to any Unintended Uses of Cypress products.

Cypress, the Cypress logo, Spansion, the Spansion logo, and combinations thereof, WICED, PSoC, CapSense, EZ-USB, F-RAM, and Traveo are trademarks or registered trademarks of Cypress in the United States and other countries. For a more complete list of Cypress trademarks, visit cypress.com. Other names and brands may be claimed as property of their respective owners.