

## “ZNR” Transient/Surge Absorbers

Type : **SC**

The ZNR Type SC protects power supply facilities, communications equipment from steep lightning surges, and it is a suitable product to incorporate it in a surge protective device corresponding to the Japanese Industrial Standards (JIS C 5381-1).



### Features

- Very large surge withstanding capability with a compact size
- Fast response to steep impulse voltage
- Low clamping voltage for better surge protection
- No follow-on current
- RoHS compliant

### Recommended Applications

- Power suppliers for OA, FA, telecommunication or industrial equipment
- Traffic or railroad systems
- Surge protection of automatic control devices for power distribution line

### As for Handling Precautions and Minimum Quantity / Packing Unit

Please see Related Information

### Explanation of Part Numbers

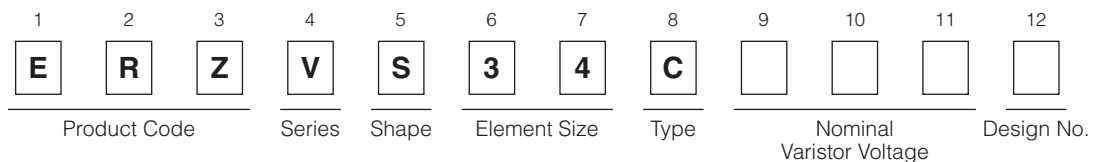

### Dimensions in mm (not to scale)

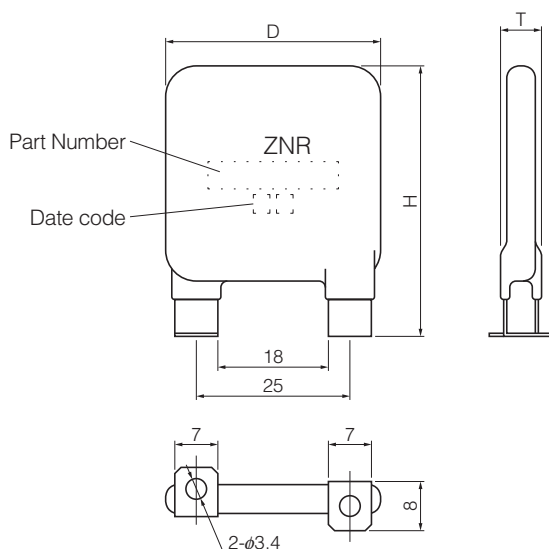

(Unit : mm)			
Part No.	D max.	H max.	T max.
ERZVS34C201	36	47	9.0
ERZVS34C241			9.2
ERZVS34C271			9.5
ERZVS34C361			10.4
ERZVS34C431			11.1
ERZVS34C471			11.3
ERZVS34C511			9.7
ERZVS34C621			9.7
ERZVS34C751			10.5
ERZVS34C821			11.0
ERZVS34C951			11.5

## Ratings and Characteristics

- Operating Temperature Range : -40 to 85 °C
- Storage Temperature Range : -40 to 125 °C

Part No.	Varistor Voltage	Maximum Allowable Voltage		Maximum Clamping Voltage	Voltage Protection Level	Nominal Discharge Current	Maximum Discharge Current
	V <sub>1mA</sub> (V)	ACrms (V)	DC (V)	V250 A	UP(V) (at 1n)	In(8/20 μs)	I <sub>max</sub> (8/20 μs)
ERZVS34C201	200(185 to 225)	130	170	340	800	20 kA	40 kA
ERZVS34C241	240(216 to 264)	150	200	395	900		
ERZVS34C271	270(247 to 303)	175	225	455	1000		
ERZVS34C361	360(324 to 396)	230	300	595	1200		
ERZVS34C431	430(387 to 473)	275	350	710	1500		
ERZVS34C471	470(423 to 517)	300	385	775	1500		
ERZVS34C511	510(459 to 561)	320	415	845	1500		
ERZVS34C621	620(558 to 682)	385	505	1025	2000		
ERZVS34C751	750(675 to 825)	460	615	1240	2500		
ERZVS34C821	820(738 to 902)	510	670	1355	2500		
ERZVS34C951	950(855 to 1045)	575	765	1570	3000		

## Typical Characteristics

Voltage vs. Current (ERZVS34C201 to ERZVS34C951)

