

## DESCRIPTION

Demonstration circuit 450 is a termination power supply that sinks or sources up to 12A current. Typical applications include termination power supplies for DDR or QDR memories. DC450 utilizes the LTC3717, a Constant On-Time, Valley Current Mode synchronous buck controller. The demo circuit provides additional footprints for paralleling more MOSFETs and input/output capacitors for higher current applications. The output voltage ( $V_{OUT}$ ) equals half of the reference voltage ( $V_{REF}$ ). The default reference voltage is the input voltage,  $V_{IN}$ . An

external reference can be provided to program the output voltage directly.

## SPECIFICATIONS

- $V_{IN}$  5V–20V
- $V_{OUT}$   $V_{REF}/2$ , preset at 1.25V
- $I_{OUT}$   $\pm 10A$  continuous,  $\pm 12A_{MAX}$  with air flow 100LFM

## SETUP NOTES

### JUMPER SETTINGS

JP1: shunt at **ADJ.** position

### EXTERNAL REFERENCE

The output of this demo board can be programmed by the external reference at the VREF pin.

**NOTE:** R11 and R12 must be removed *before* applying  $V_{REF}$ .

### APPLY 5V TO EXTVCC:

LTC3717 has an internal 5V LDO that provides the gate drive for power MOSFETs. When an external 5V source is available, apply this 5V to EXTVCC pin to disable the internal LDO. This will improve efficiency for high  $V_{IN}$  applications.

## QUICK START PROCEDURE

Refer to Figure 1 and Figure 2 for proper measurement equipment setup and follow the procedure below:

1. Connect the input 5V–20V power source to the  $V_{IN}$  and GND pins using wires capable of handling 4A current.
2. Turn on the input power supply.
3. Adjust R12 such that  $V_{REF} = 2.5V$  (the default reference voltage).
4. Measure  $V_{OUT}$ . It should read about  $1.25V \pm 0.05V$ .

### SOURCING CURRENT TEST (FIGURE 1)

5. Turn off the input power supply  $V_{IN}$  first.
6. Connect the load to the  $V_{OUT}$  and GND pins with the positive terminal of the load connecting to  $V_{OUT}$ .

7. Turn on  $V_{IN}$ .
8. Increase the load current to 10A.  $V_{OUT}$  should always equal  $V_{REF}/2 \pm 0.05V$ . If  $V_{REF}$  is fixed at 2.5V,  $V_{OUT}$  should read about  $1.25V \pm 0.05V$ .

### SINKING CURRENT TEST (FIGURE 2)

9. Turn off the input power supply  $V_{IN}$  first.
10. Connect the load to the  $V_{IN}$  and  $V_{OUT}$  pins with the positive terminal of the load connecting to  $V_{IN}$  and the negative terminal of load connecting to  $V_{OUT}$ .
11. Turn on  $V_{IN}$ .
12. Increase the load current to 10A. If  $V_{REF}$  is fixed at 2.5V,  $V_{OUT}$  should read about  $1.25V \pm 0.05V$ .

# DEMO BOARD QUICK START GUIDE 450

## DDR, HSTL, STTL TERMINATION POWER SUPPLY

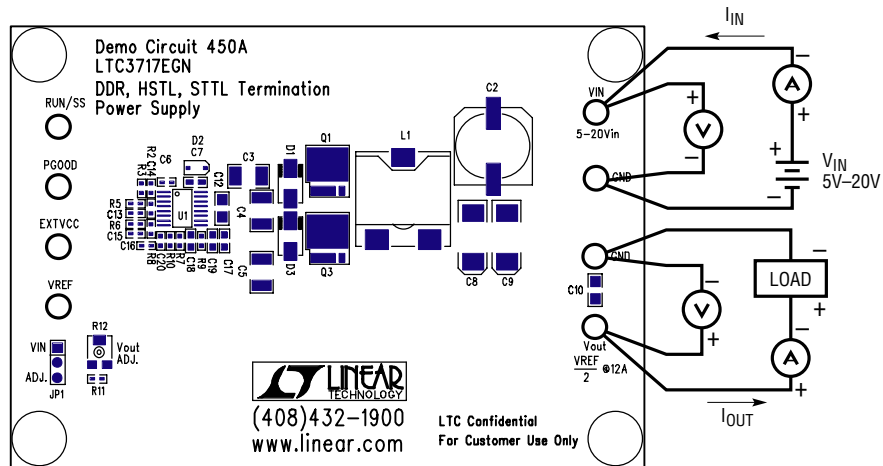

Figure 1. Proper Measurement Equipment Setup for Output Sourcing Current

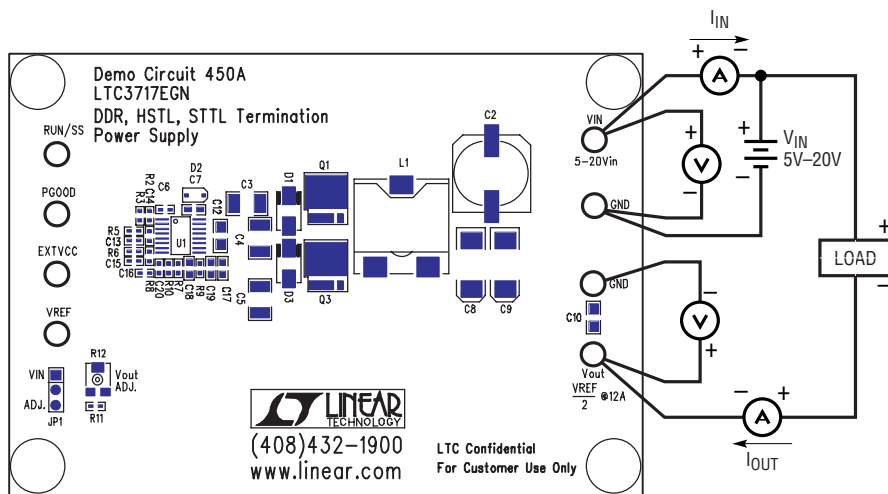

Figure 2. Proper Measurement Equipment Setup for Output Sinking Current