

- 50 W at 25°C Case Temperature
- 10 A Continuous Collector Current
- 15 A Peak Collector Current
- Maximum  $V_{CE(sat)}$  of 2.8 V at  $I_C = 6.5$  A
- $I_{CEX(sus)}$  7 A at rated  $V_{(BR)CEO}$

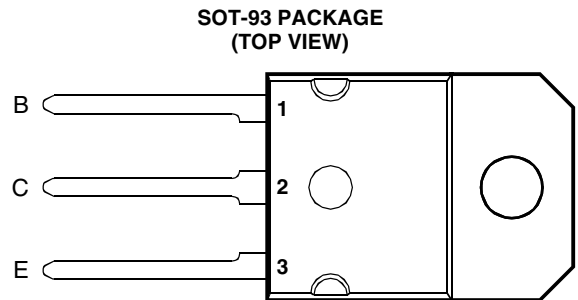

Pin 2 is in electrical contact with the mounting base.

MDTRAAA

**absolute maximum ratings at 25°C case temperature (unless otherwise noted)**

RATING		SYMBOL	VALUE	UNIT
Collector-base voltage ( $I_E = 0$ )	TIP160	$V_{CBO}$	320	V
	TIP161		350	
	TIP162		380	
Collector-emitter voltage ( $I_B = 0$ )	TIP160	$V_{CEO}$	320	V
	TIP161		350	
	TIP162		380	
Emitter-base voltage		$V_{EBO}$	5	V
Continuous collector current		$I_C$	10	A
Peak collector current (see Note 1)		$I_{CM}$	15	A
Peak commutating anti-parallel diode current ( $I_B = 0$ ) (see Note 2)		$I_{EM}$	10	A
Continuous base current		$I_B$	1	A
Continuous device dissipation at (or below) 100°C case temperature (see Note 3)		$P_{tot}$	50	W
Continuous device dissipation at (or below) 25°C free air temperature (see Note 4)		$P_{tot}$	3	W
Operating junction temperature range		$T_j$	-65 to +150	°C
Storage temperature range		$T_{stg}$	-65 to +150	°C
Lead temperature 3.2 mm from case for 10 seconds		$T_L$	260	°C

- NOTES: 1. This value applies for  $t_p \leq 10$  ms, duty cycle  $\leq 10\%$ .  
 2. This value applies to the total collector-terminal current when the collector is at negative potential with respect to the emitter.  
 3. Derate linearly to 150°C case temperature at the rate of 0.4 W/°C.  
 4. Derate linearly to 150°C free air temperature at the rate of 24 mW/°C.

**PRODUCT INFORMATION**

JUNE 1973 - REVISED SEPTEMBER 2002  
 Specifications are subject to change without notice.

**electrical characteristics at 25°C case temperature**

PARAMETER	TEST CONDITIONS	MIN	TYP	MAX	UNIT
$I_{CEO}$ Collector-emitter cut-off current	$V_{CE} = 320\text{ V}$ $I_B = 0$ TIP160 $V_{CE} = 350\text{ V}$ $I_B = 0$ TIP161 $V_{CE} = 380\text{ V}$ $I_B = 0$ TIP162			1	mA
$I_{CEX(sus)}$ Collector-emitter sustaining current	$V_{CLAMP} = V_{(BR)CEO}$	7			A
$I_{EBO}$ Emitter cut-off current	$V_{EB} = 5\text{ V}$ $I_C = 0$			100	mA
$h_{FE}$ Forward current transfer ratio	$V_{CE} = 2.2\text{ V}$ $I_C = 4\text{ A}$ (see Notes 5 and 6)	200			
$V_{CE(sat)}$ Collector-emitter saturation voltage	$I_B = 0.1\text{ A}$ $I_C = 6.5\text{ A}$ (see Notes 5 and 6) $I_B = 1\text{ A}$ $I_C = 10\text{ A}$			2.8 2.9	V
$V_{BE(sat)}$ Base-emitter saturation voltage	$I_B = 0.1\text{ A}$ $I_C = 6.5\text{ A}$ (see Notes 5 and 6)			2.2	V
$V_{EC}$ Parallel diode forward voltage	$I_E = 10\text{ A}$ $I_B = 0$ (see Notes 5 and 6)			3.5	V

NOTES: 5. These parameters must be measured using pulse techniques,  $t_p = 300\text{ }\mu\text{s}$ , duty cycle  $\leq 2\%$ .

6. These parameters must be measured using voltage-sensing contacts, separate from the current carrying contacts.

**thermal characteristics**

PARAMETER	MIN	TYP	MAX	UNIT
$R_{\theta JC}$ Junction to case thermal resistance			1	°C/W
$R_{\theta JA}$ Junction to free air thermal resistance			41.7	°C/W
$C_{\theta C}$ Thermal capacitance of case		1.4		J/°C

**resistive-load-switching characteristics at 25°C case temperature**

PARAMETER	TEST CONDITIONS †	MIN	TYP	MAX	UNIT
$t_d$ Delay time	$I_C = 6.5\text{ A}$ $I_{B(on)} = 100\text{ mA}$ $I_{B(off)} = -100\text{ mA}$ $V_{BE(off)} = -5\text{ V}$ $R_L = 5\text{ }\Omega$		40		ns
$t_r$ Rise time			1.5		$\mu\text{s}$
$t_s$ Storage time			2.2		$\mu\text{s}$
$t_f$ Fall time			2.6		$\mu\text{s}$

† Voltage and current values shown are nominal; exact values vary slightly with transistor parameters.

**PRODUCT INFORMATION**

JUNE 1973 - REVISED SEPTEMBER 2002  
Specifications are subject to change without notice.

**PARAMETER MEASUREMENT INFORMATION**

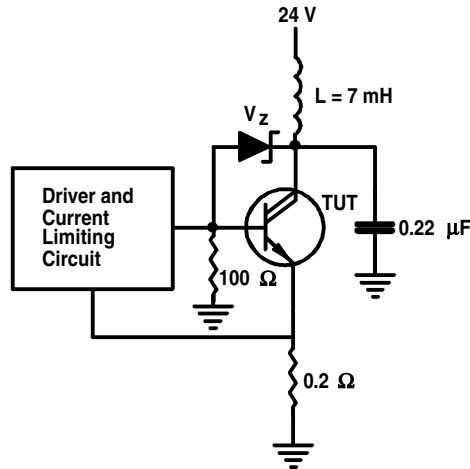

**Figure 1. Functional Test Circuit**

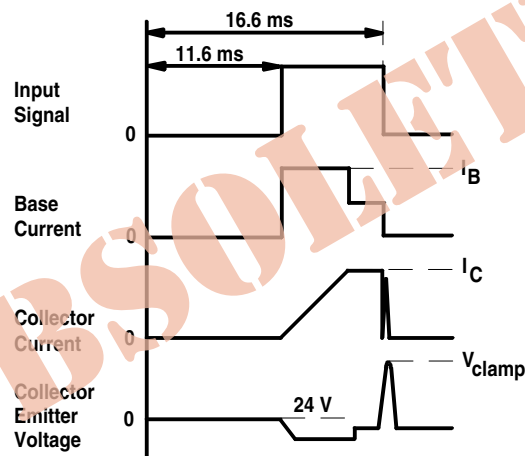

**Figure 2. Functional Test Waveforms**

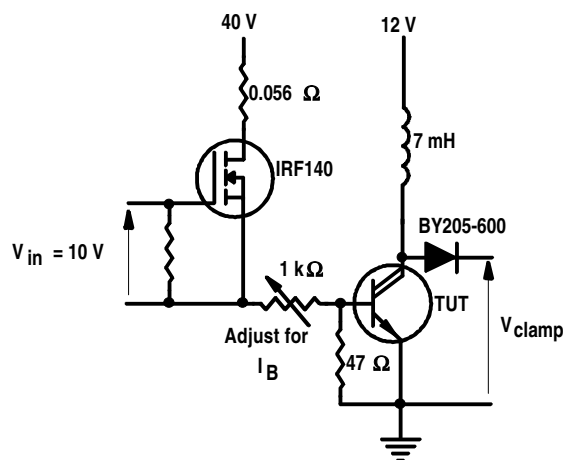

**Figure 3. Switching Test Circuit**

**PRODUCT INFORMATION**

JUNE 1973 - REVISED SEPTEMBER 2002  
Specifications are subject to change without notice.

TYPICAL CHARACTERISTICS

TYPICAL DC CURRENT GAIN  
vs  
COLLECTOR CURRENT

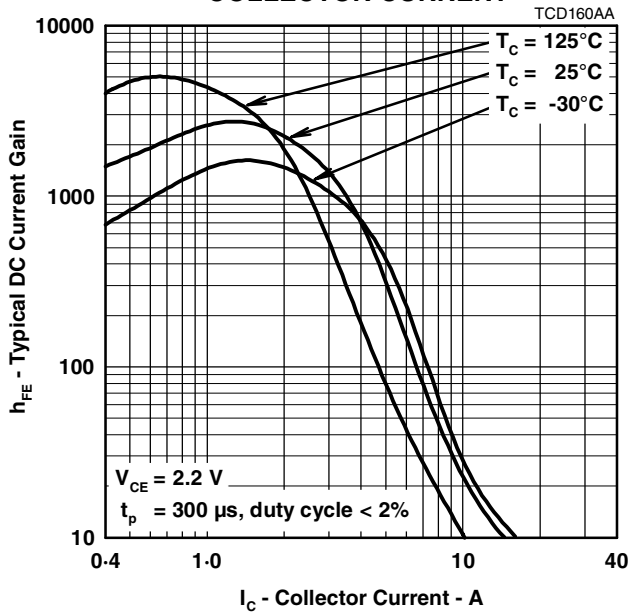

Figure 4.

COLLECTOR-EMITTER SATURATION VOLTAGE  
vs  
COLLECTOR CURRENT

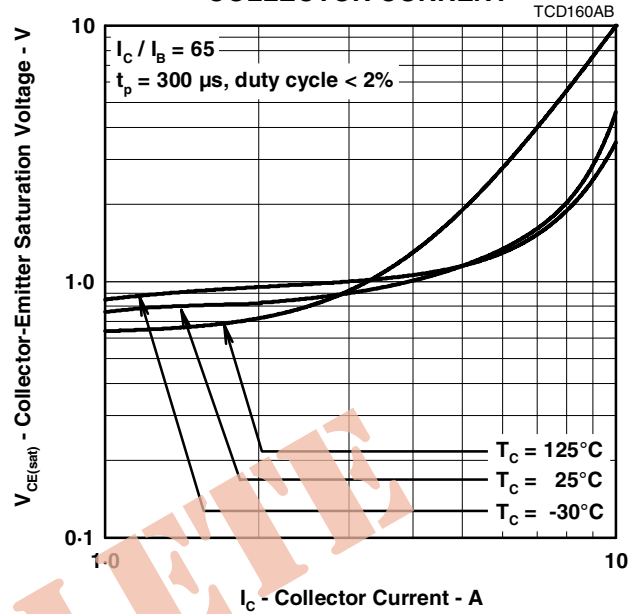

Figure 5.

COLLECTOR-EMITTER SATURATION VOLTAGE  
vs  
COLLECTOR CURRENT

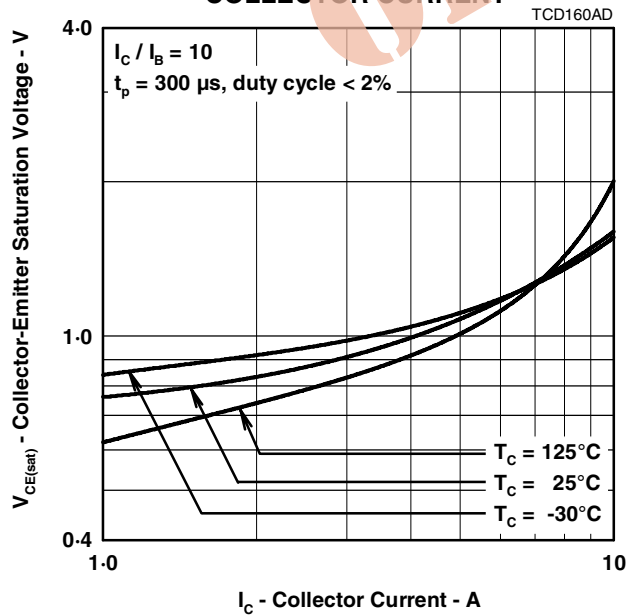

Figure 6.

BASE-EMITTER SATURATION VOLTAGE  
vs  
COLLECTOR CURRENT

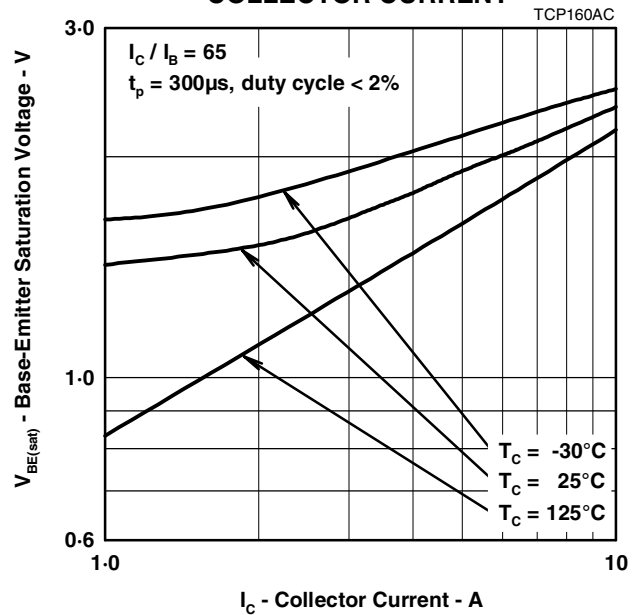

Figure 7.

**PRODUCT INFORMATION**

JUNE 1973 - REVISED SEPTEMBER 2002  
Specifications are subject to change without notice.

**MAXIMUM SAFE OPERATING REGIONS**

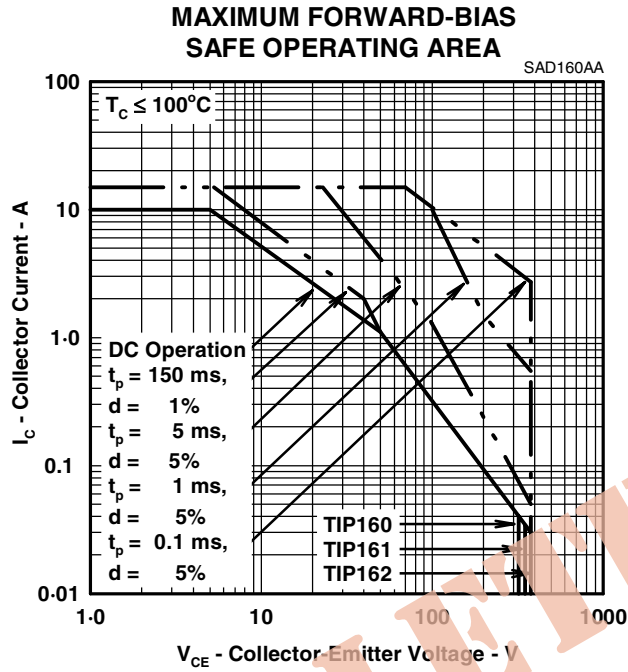

Figure 8.

OBSOLETE

**PRODUCT INFORMATION**

JUNE 1973 - REVISED SEPTEMBER 2002  
Specifications are subject to change without notice.