

DESCRIPTION

Demonstration circuit 647 is a 1.2MHz, SOT-23 DC/DC Converter featuring the LT[®]3467. The demo board demonstrates two separate DC/DC converters for different application needs. The Boost Circuit is designed to convert a 5V input to 12V output at 300mA maximum load. The SEPIC Circuit generates a constant 12V/300mA output with 10V~16V variable input. Both circuits are designed to demonstrate the soft start feature, advantages of the 1.2MHz switching frequency, the internal 42V/1.1A switch, wide input voltage range and small circuit size. These circuits are intended for space-conscious applications such

as digital cameras, cellular phones, palmtop computers and LCD displays. The 1.2MHz switching frequency, 1.1A integrated switch, small circuit size, and low component count makes the LT3467 suitable for use in many other applications, such as PC cards, miniature disk drives, xDSL power supplies, flash memory products and local 5V or 12V supplies.

Design files for this circuit board are available. Call the LTC factory.

LT is a registered trademark of Linear Technology Corporation

Table 1. Performance Summary (T_A = 25°C)

| PARAMETERS FOR BOOST CONVERTER | CONDITION | VALUE |
|--|--|---------------------|
| Input Voltage | | 5V |
| Output Voltage V _{OUT} | V _{IN} = 5V, I _{OUT} = 0A to 300mA | 12V ±2% |
| Maximum Output Current | | 300mA |
| Typical Output Ripple V _{OUT} | V _{IN} = 5, I _{OUT} = 300mA | 55mV _{P-P} |
| Typical efficiency | V _{IN} = 5, I _{OUT} = 300mA | 86% |
| PARAMETERS FOR SEPIC CONVERTER | CONDITION | VALUE |
| Minimum Input Voltage | | 10V |
| Maximum Input Voltage | | 16V |
| Output Voltage V _{OUT} | V _{IN} = 10V to 16V, I _{OUT} = 0A to 300mA | 12V ±2% |
| Maximum Output Current | | 300mA |
| Typical Output Ripple V _{OUT} | V _{IN} = 10V, I _{OUT} = 300mA | 50mV _{P-P} |
| Typical efficiency | V _{IN} = 10V to 16V, I _{OUT} = 300mA | 80% |

QUICK START PROCEDURE

Demonstration circuit 647 is easy to set up to evaluate the performance of the LT3467. Refer to Figure 1 for proper measurement equipment setup and follow the procedure below:

NOTE: When measuring the input or output voltage ripple, care must be taken to avoid a long ground lead

on the oscilloscope probe. Measure the input or output voltage ripple by touching the probe tip directly across the V_{IN} or V_{OUT} and GND terminals. See Figure 2 for proper scope probe technique.

NOTE: Steps 1-4 are for Boost Converter only.

1. Place jumper in the following positions:

QUICK START GUIDE FOR DEMONSTRATION CIRCUIT 647

1.2MHZ, SOT-23 DC/DC CONVERTER

JP1 On

2. With power off, connect the input power supply to V_{IN} and GND.
3. Turn on the power at the input.

NOTE: Make sure that the input voltage does not exceed 5V.

4. Check for the proper output voltages.

NOTE: If there is no output, temporarily disconnect the load to make sure that the load is not set too high.

NOTE: Once the proper output voltages are established, adjust the loads within the operating range and observe the output voltage regulation, ripple voltage, efficiency and other parameters directly across the V_{IN} or V_{OUT} and GND terminals. See Figure 2 for proper scope probe technique.

NOTE: Steps 5-9 are for Sepic converter only.

5. Place jumper in the following positions:

JP2 On

6. With power off, connect the input power supply to V_{IN} and GND.
7. Turn on the power at the input.

NOTE: Make sure that the input voltage is set between 10V and 16V.

8. Check for the proper output voltages.

NOTE: If there is no output, temporarily disconnect the load to make sure that the load is not set too high.

9. Once the proper output voltages are established, adjust the loads within the operating range and observe the output voltage regulation, ripple voltage, efficiency and other parameters.

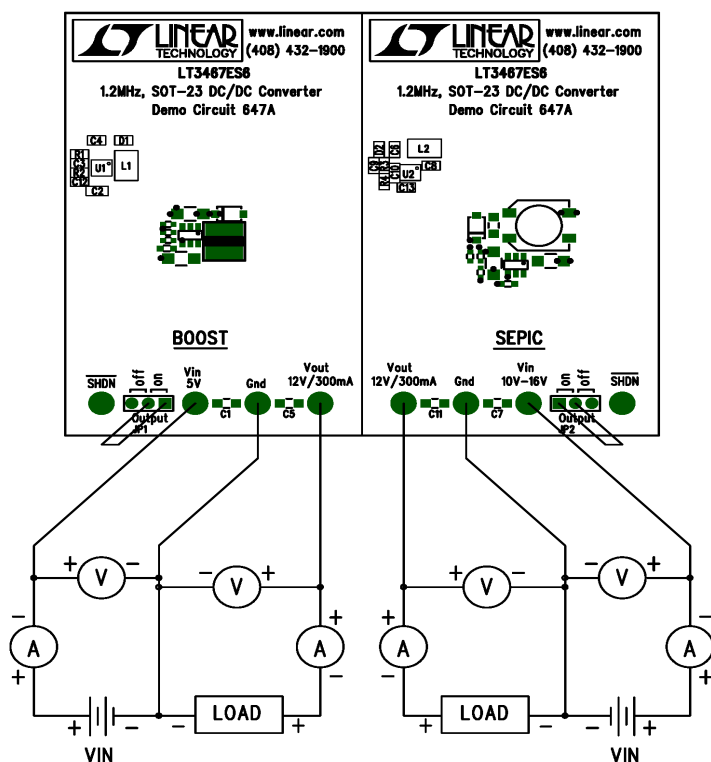

Figure 1. Proper Measurement Equipment setup

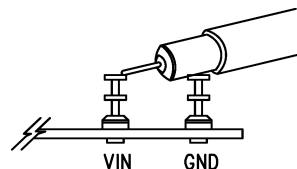
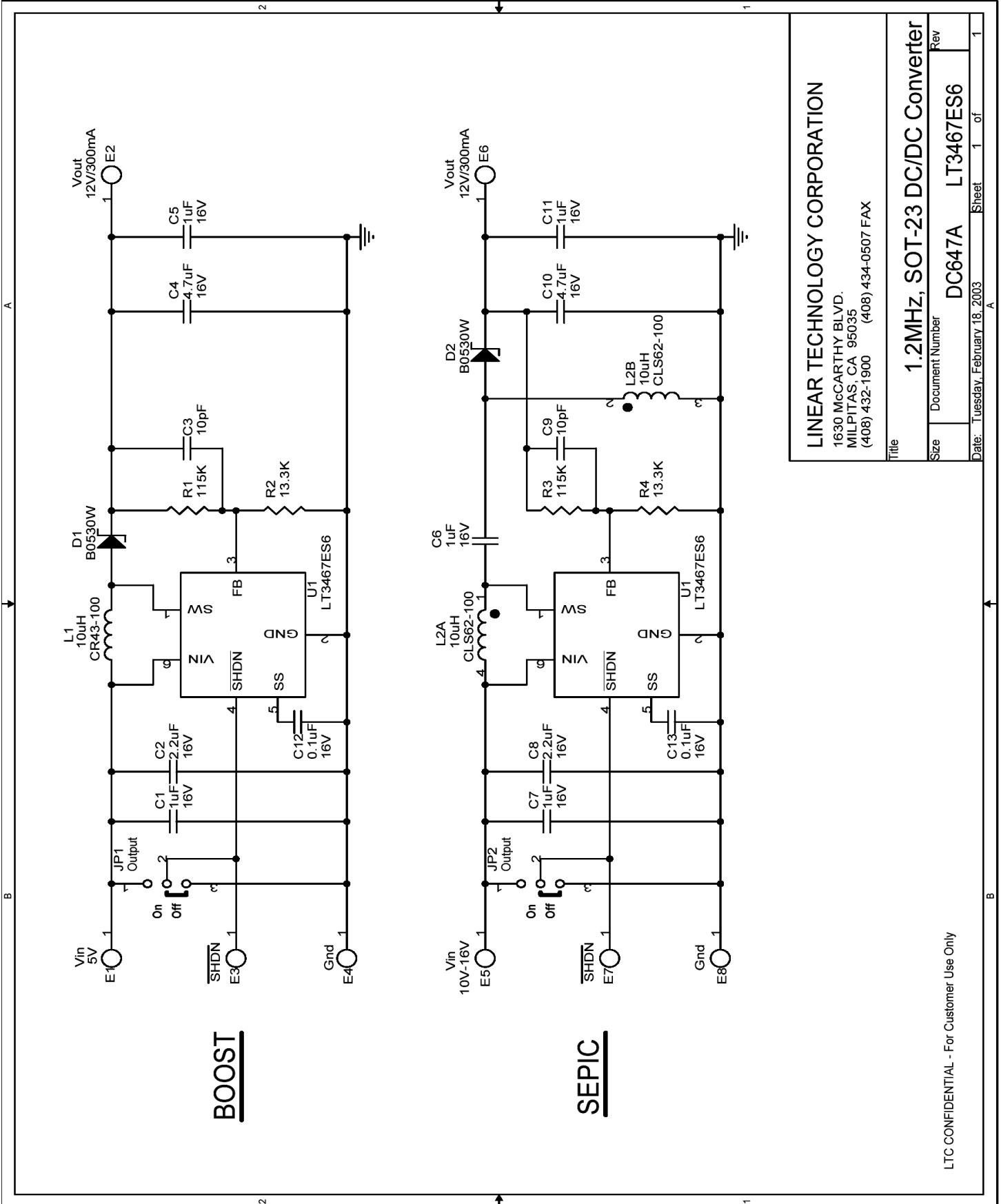

Figure 2. Measurement Input or Output Ripple

QUICK START GUIDE FOR DEMONSTRATION CIRCUIT 647

1.2MHZ, SOT-23 DC/DC CONVERTER



LINEAR TECHNOLOGY CORPORATION
 1630 MCCARTHY BLVD.
 MILPITAS, CA 95035
 (408) 432-1900 (408) 434-0507 FAX

Title: **1.2MHz, SOT-23 DC/DC Converter**

| | | |
|------|-----------------|-----------|
| Size | Document Number | Rev |
| | DC647A | LT3467ES6 |

Date: Tuesday, February 18, 2003 Sheet 1 of 1

LTC CONFIDENTIAL - For Customer Use Only