

# QUICK START GUIDE FOR DEMONSTRATION CIRCUIT 913 POLYPHASE 3-OUTPUT STEP-DOWN SUPPLY WITH TRACKING

## LTC3773EUHF

### DESCRIPTION

Demonstration circuit 913 is a high efficiency and high density supply featuring the 3-output, 3-phase synchronous buck regulator LTC3773. The input voltage range of the demo board is designed for 4.5V to 13.5V, though the LTC3773 controller can take up to  $36V_{MAX}$   $V_{in}$ . The outputs of this board are 2.5V/15A, 1.8V/15A and 1.2V/15A. To minimize input ripple current and capacitor size, there is 120° phase clock interleaving among every two phases. The power up/down tracking of the three output voltages is programmable. The supply can be synchronized to an external clock signal.

The critical power components are on the top side of the PC board and are within a 1.7" x 1.7" "drop-in" layout area. The small signal components and IC are on the bottom side of the PC board within a 1" x 1" board area. The LTC3773EUHF regulator IC is in a small 5mm x 7mm QFN package with exposed thermal pad for low thermal impedance. An optional 5V bias supply is stuffed on the board to power the LTC3773.

**Design files for this circuit board are available.  
Call the LTC factory.**

 , LTC and LT are registered trademarks of Linear Technology Corporation.

**Table 1. Performance Summary ( $T_A = 25^\circ\text{C}$ )**

PARAMETER	CONDITION	VALUE
Input Voltage	Typical	4.5V-13.5V (15V abs_max)
Output Voltage $V_{OUT1}$	$I_{OUT1} = 0A$ to 15A	$2.5V \pm 2\%$
Output Voltage $V_{OUT2}$	$I_{OUT2} = 0A$ to 15A	$1.8V \pm 2\%$
Output Voltage $V_{OUT3}$	$I_{OUT3} = 0A$ to 15A	$1.2V \pm 2\%$
Maximum Output Current	$V_{IN} = 4.5V-13.5V$	15A Each Output
Switching frequency	4.5V-13.5V <sub>in</sub>	400kHz
Full Load Efficiency	$V_{IN} = 12V, V_{OUT1} = 2.5V, I_{OUT1} = 15A$	90% Typical
	$V_{IN} = 12V, V_{OUT2} = 1.8V, I_{OUT2} = 15A$	88 % Typical
	$V_{IN} = 12V, V_{OUT3} = 1.2V, I_{OUT3} = 15A$	84.5 % Typical

### QUICK START PROCEDURE

Demonstration circuit 913 is easy to set up to evaluate the performance of the LTC3773EUHF. Refer to Figure 1 for proper measurement equipment setup and follow the procedure below:

# QUICK START GUIDE FOR DEMONSTRATION CIRCUIT 913

## POLYPHASE 3-OUTPUT STEP-DOWN SUPPLY WITH TRACKING

**NOTE:** When measuring the input or output voltage ripple, care must be taken to avoid a long ground lead on the oscilloscope probe. Measure the input or output voltage ripple by touching the probe tip directly across the Vin or Vout and GND terminals. See Figure 2 for proper scope probe technique.

1. The following are the default jumper settings:

+5V Select	INT 5V	PHASMD	SDB1	SDB2	SDB3	FC
INT.	ON	120	ON	ON	ON	CCM

The following tables show the assembly options to program the power up/down tracking among Vout1, Vout2 and Vout3:

	VOUT1 TRACKING OPTIONS	R8	C13	C10
1*	Softstart W/O tracking	0	DNP	0.01uF
2	Track TRACK1	Stuff, value TBD	Stuff R, value TBD	DNP

	VOUT2 TRACKING OPTIONS	R13	R18	C22
1	Softstart W/O tracking	DNP	DNP	0.01uF
2*	Track VOUT1	20K	10K	DNP

	VOUT3 TRACKING OPTIONS	R28	R30	C29
1	Softstart W/O tracking	DNP	DNP	0.01uF
2*	Track VOUT2	10K	10K	DNP

\*With existing tracking circuit assembly, VOUT1 starts independently (Option 1). VOUT2 tracks VOUT1 during start up (option 2). VOUT3 tracks VOUT2 during start up (option 2). Figure 6 and 7 are the typical power-up/down waveforms with rail tracking.

- With power off, connect the input power supply to VIN and GND. Connect the loads between VOUT1, VOUT2, VOUT3 and GND. Preset the load current at 0A (minimum). Refer to Figure 1 for correct test set up.
- Turn on the input power.
 

**NOTE:** Make sure that the input voltage does not exceed 15V.
- Check for the proper output voltages:  $V_{OUT1}$ : 2.45V-2.55V,  $V_{OUT2}$ : 1.764V – 1.836V, and  $V_{OUT3}$ : 1.176V – 1.224V
 

**NOTE:** If there is no output, temporarily disconnect the load to make sure that the load is not set too high.
- Once the proper output voltages are established, adjust the loads within the operating range and observe the output voltage regulation, ripple voltage, efficiency and other parameters.

# QUICK START GUIDE FOR DEMONSTRATION CIRCUIT 913

## POLYPHASE 3-OUTPUT STEP-DOWN SUPPLY WITH TRACKING

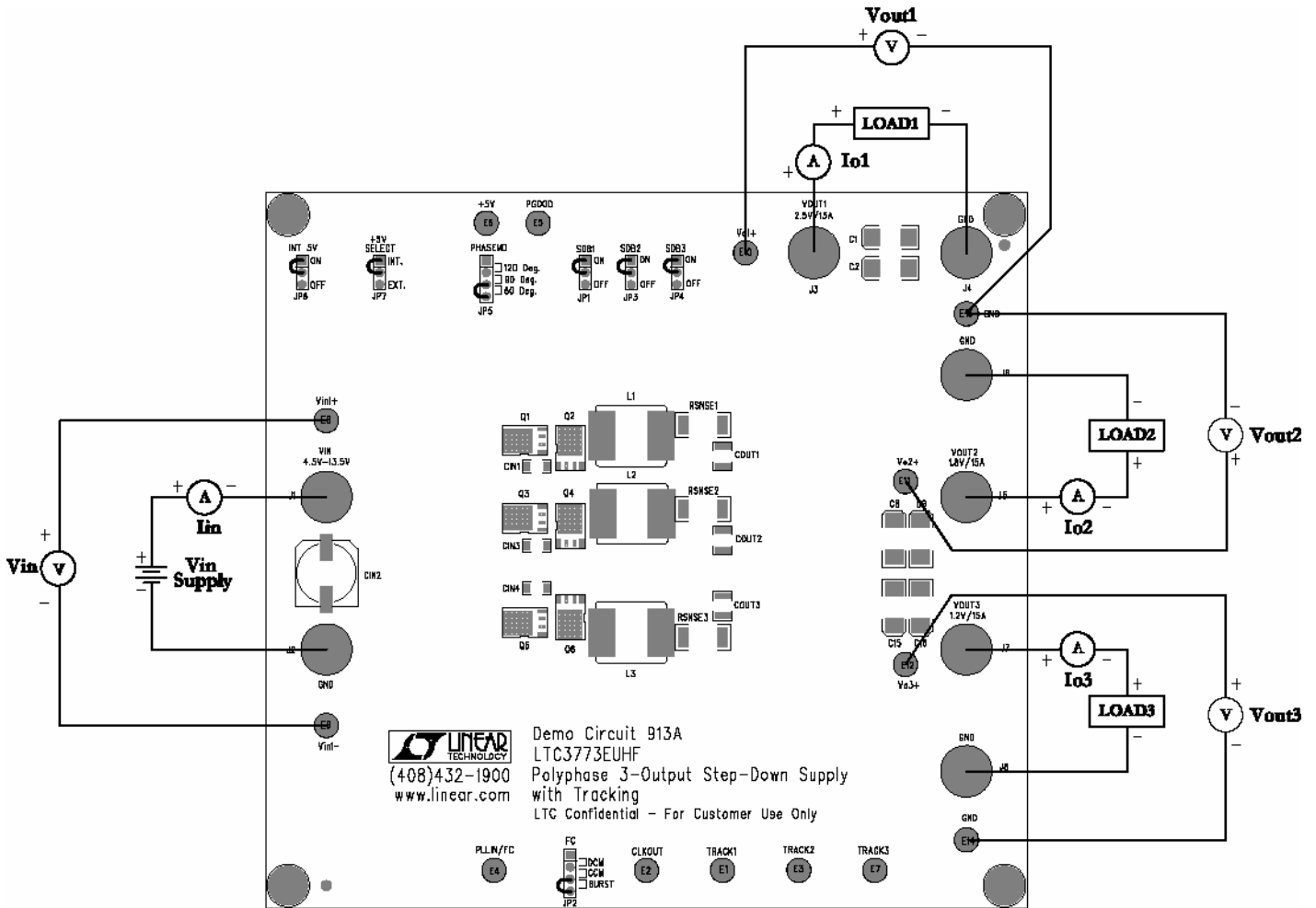

Figure 1. Proper Measurement Equipment Setup

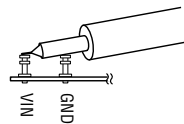

Figure 2. Measuring Input or Output Ripple

# QUICK START GUIDE FOR DEMONSTRATION CIRCUIT 913

## POLYPHASE 3-OUTPUT STEP-DOWN SUPPLY WITH TRACKING

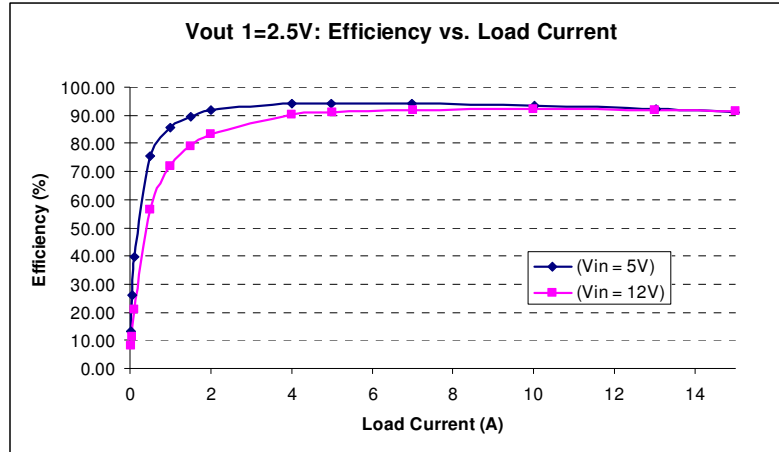

Figure 3. Typical Supply Efficiency vs Load Current of 2.5V output

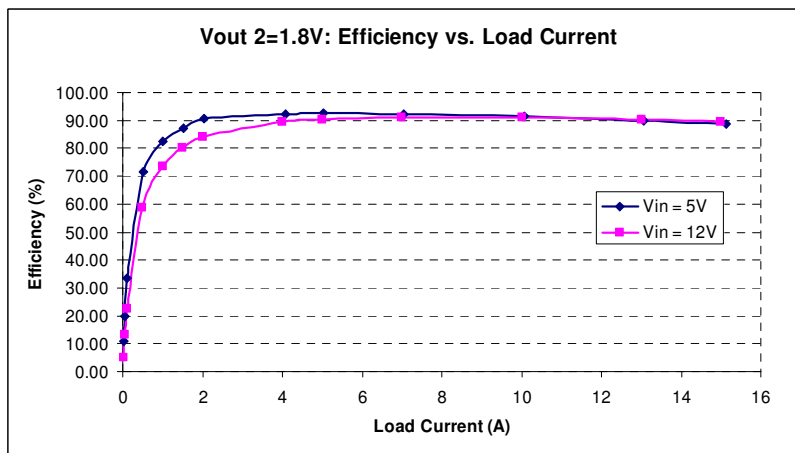

Figure 4. Typical Supply Efficiency vs Load Current of 1.8V output

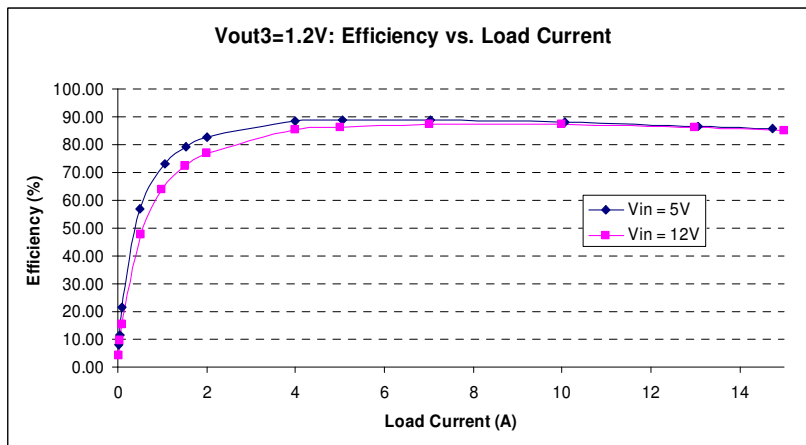

Figure 5. Typical Supply Efficiency vs Load Current of 1.2V output

# QUICK START GUIDE FOR DEMONSTRATION CIRCUIT 913

## POLYPHASE 3-OUTPUT STEP-DOWN SUPPLY WITH TRACKING

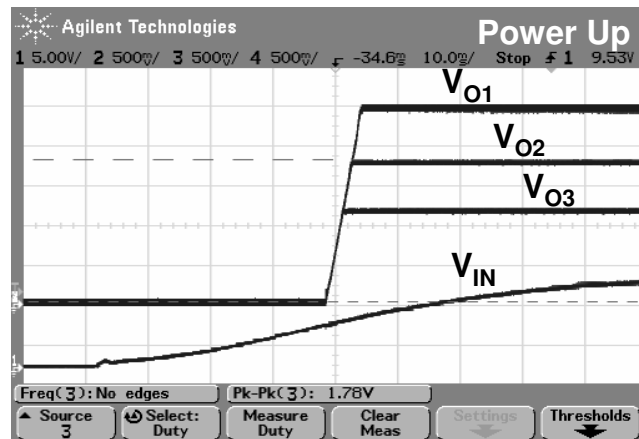

Figure 6. Power Up Tracking

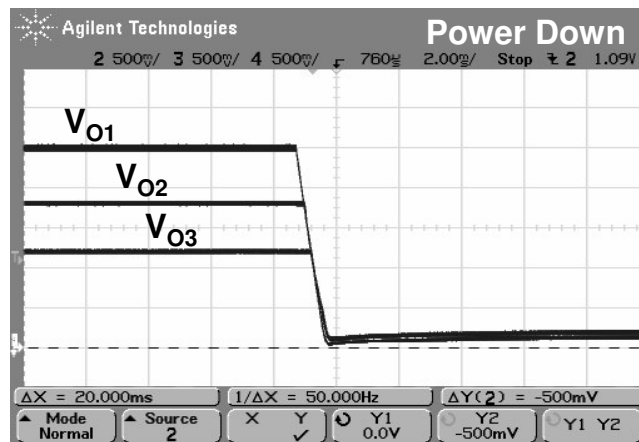
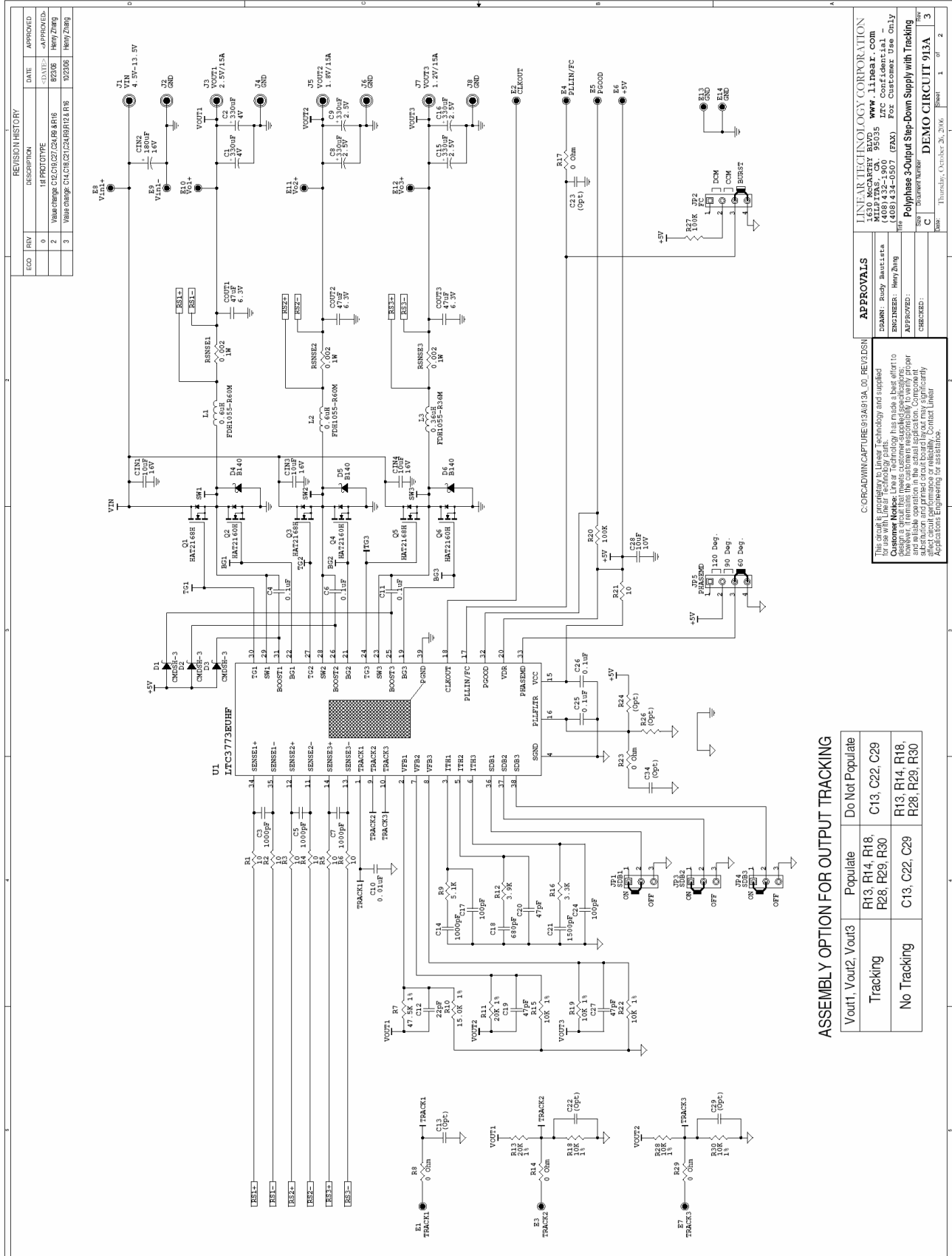

Figure 7. Power Down Tracking

# QUICK START GUIDE FOR DEMONSTRATION CIRCUIT 913

## POLYPHASE 3-OUTPUT STEP-DOWN SUPPLY WITH TRACKING



# QUICK START GUIDE FOR DEMONSTRATION CIRCUIT 913

## POLYPHASE 3-OUTPUT STEP-DOWN SUPPLY WITH TRACKING

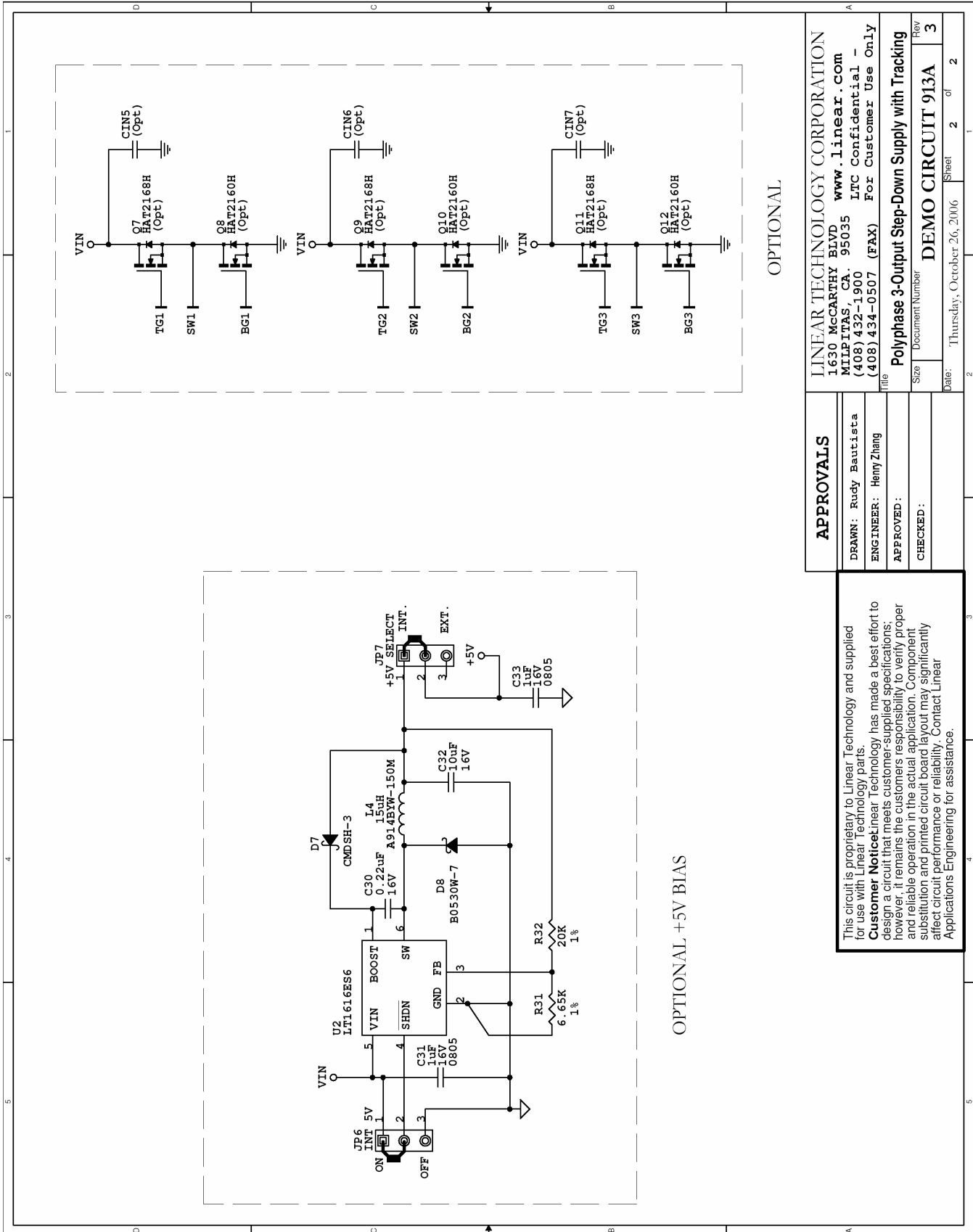

<b>APPROVALS</b>	
DRAWN: Rudy Bautista	
ENGINEER: Henry Zhang	
APPROVED:	
CHECKED:	
File	LINEAR TECHNOLOGY CORPORATION 1630 MCCARTHY BLVD MILPITAS, CA. 95035 (408) 432-1900 (408) 434-0507 (FAX) For Customer Use Only
Size	Document Number
Rev	<b>3</b>
Date:	Thursday, October 26, 2006
Sheet	2 of 2

This circuit is proprietary to Linear Technology and supplied for use with Linear Technology parts.  
**Customer Notice:** Linear Technology has made a best effort to design a circuit that meets customer-supplied specifications; however, it remains the customer's responsibility to verify proper and reliable operation in the actual application. Component substitution and printed circuit board layout may significantly affect circuit performance or reliability. Contact Linear Applications Engineering for assistance.