

TCO Series

Conductive Polymer Chip Capacitors (Standard)



FEATURES

- Ta-polymer technology
- High ripple capability
- High CV
- Surge robust
- J-lead LF

APPLICATIONS

- DC/DC
- Industrial
- Computers
- Telecom
- IoT
- Home applications



MARKING

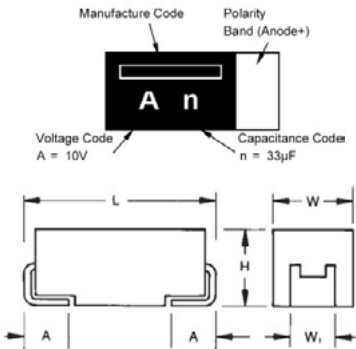

CASE DIMENSIONS:

millimeters (inches)

Code	EIA Code	EIA Metric	L±0.20 (0.008)	W±0.20 (0.008)	H±0.20 (0.008)	W ₁ ±0.20 (0.008)	A±0.30 (0.012)
B	1210	3528-21	3.50 (0.138)	2.80 (0.110)	1.90 (0.075)	1.90 (0.075)	0.80 (0.031)

HOW TO ORDER

TCO
Type

B
Case Size
See table above

1A
Rated DC Voltage
0E = 2.5Vdc
0J = 6.3Vdc
1A = 10Vdc
1C = 16Vdc
1E = 25Vdc

336
Capacitance Code
pF code: 1st two digits represent significant figures, 3rd digit represents multiplier (number of zeros to follow)

M
Tolerance
M = ±20%

8R
Packaging
8 = Tape width
R = Positive electrode on the side opposite to sprocket hole

- **□□□**
Discrimination code

TECHNICAL SPECIFICATIONS

Technical Data:	All technical data relate to an ambient temperature of +25°C
Capacitance Range:	15µF to 330µF
Capacitance Tolerance:	±20%
Leakage Current DCL:	Please see the ratings and part number reference table below
Temperature Range:	-55°C to +105°C

Note: Conductive Polymer Capacitors are designed to operate within the limits of the environmental conditions specified for each series. If operated continuously at their maximum temperature and / or humidity limit, or beyond these limits, capacitors may exhibit a parametric shift in capacitance and increases in ESR. These changes may occur earlier if the specified environmental conditions are exceeded. Similarly, their normal operational time period will be significantly extended if their general duty cycle includes operation below maximum temperature within humidity controlled environments. Careful attention should be paid to maximum temperature with associated high humidity environments as well as voltage derating, ripple current and current surges.

Please reference the KYOCERA AVX Conductive Polymer Capacitor Guidelines for more information or contact factory for application assistance

TCO Series

Conductive Polymer Chip Capacitors (Standard)

CAPACITANCE AND RATED VOLTAGE RANGE (LETTER DENOTES CASE SIZE)

Capacitance		Rated Voltage DC (V _R) @ 105°C					Cap Code
μF	Code	2.5V(e)	6.3V(j)	10V(A)	16V(C)	25V(E)	
15	156					100	e
22	226					90	j
33	336			150	100		n
47	476			150			s
100	107		35,45				ā
150	157		35,45				ē
220	227	35	35				ī
330	337	35,45					ñ

Released ratings, (ESR ratings in mOhms)

Note: Voltage ratings are minimum values. KYOCERA AVX reserves the right to supply higher voltage ratings in the same case size, to the same reliability standards.

RATINGS & PART NUMBER REFERENCE

Part No.	Case Size	Capacitance (μF)	Rated Voltage (V)	Maximum Operating Temp. (°C)	DCL Max. (μA)	DF Max. (%)	ESR Max. @100kHz (mΩ)	100kHz RMS Current (mA) 45°C	MSL
2.5 Volt									
TCOB0E227M8R-EN1	B	220	2.5	105	55.0	8	35	1900	3
TCOB0E337M8R-EN2	B	330	2.5	105	82.5	15	35	1900	3
TCOB0E337M8R-ES2	B	330	2.5	105	82.5	15	45	1700	3
6.3 Volt									
TCOB0J107M8R-EN1	B	100	6.3	105	63.0	8	35	1900	3
TCOB0J107M8R-ES1	B	100	6.3	105	63.0	8	45	1700	3
TCOB0J157M8R-EN1	B	150	6.3	105	95.5	15	35	1900	3
TCOB0J157M8R-ES2	B	150	6.3	105	94.5	15	45	1700	3
TCOB0J227M8R-EN1	B	220	6.3	105	139.0	15	35	1900	3
10 Volt									
TCOB1A336M8R	B	33	10	105	33.0	8	150	900	3
TCOB1A476M8R	B	47	10	105	47.0	8	150	900	3
16 Volt									
TCOB1C336M8R	B	33	16	105	159.0	10	100	1100	3
25 Volt									
TCOB1E156M8R	B	15	25	105	113.0	10	100	1100	3
TCOB1E226M8R-EB1	B	22	25	105	55.0	10	90	1200	3

Moisture Sensitivity Level (MSL) is defined according to J-STD-020.
All technical data relates to an ambient temperature of +25C.

Capacitance and DF are measured at 120Hz, 0.5RMS with DC bias of 1.5 volts.
DCL is measured at rated voltage after 5 minutes.
ESR allowed to move up to 1.25 times catalog limit post mounting.

NOTE: KYOCERA AVX reserves the rights to supply higher voltage rating in the same case size, to the same reliability standards.

TCO Series

Conductive Polymer Chip Capacitors (Standard)

QUALIFICATION TABLE

TEST	TCO series (Temperature range -55°C to 105°C)				
	Condition		Characteristics		
Endurance	Apply rated voltage (Ur) at 105°C for 1000hrs through a serial resistance of $\leq 3.0\Omega$. Stabilize at room temperature for 24 hours before measuring.		Visual examination	no visible damage	
			DCL	2x initial limit	
			$\Delta C/C$	within $\pm 20\%$ of initial value	
			DF	1.5x initial limit	
Humidity	Apply rated voltage (Ur) at $60\pm 2^\circ\text{C}$, 90-95% relative humidity for 500+ 12/0 hours. Stabilize at room temperature and humidity for 24 hours before measuring.		Visual examination	no visible damage	
			DCL	1.5x initial limit	
			$\Delta C/C$	within +30/-20% of initial value	
			DF	1.5x initial limit	
Temperature Stability	Step	Temperature°C	Duration(min)		
	1	-55	15		
	2	+105	15		
				DCL	-55°C
Surge Voltage	Apply 1.3x rated voltage (Ur) at $85\pm 2^\circ\text{C}$ for 1000 cycles, 300sec charge and 30sec discharge resistance 1000 Ω .		Visual examination	no visible damage	
			DCL	initial limit	
			$\Delta C/C$	$\pm 20\%$ of initial limit	
			DF	initial limit	
Vibration	4.17 JIS C 5101-1 Frequency: 10 to 55 to 10Hz/min. Amplitude: 1.5mm Time: 2hours each in X and Y directions		Visual examination	no visible damage	
			DCL	initial limit	
			$\Delta C/C$	within $\pm 5\%$ of initial value	
			DF	initial limit	

*Initial Limit
For use outside of recommended conditions and special request, please contact KYOCERA AVX.
Initial measurement max. 1hr after the removal from dry pack or after pretreatment at 85°C for 24 hours.

PACKAGING SPECIFICATIONS

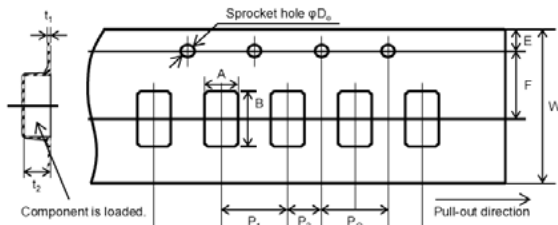

Unit (mm)

Case	A ± 0.10	B ± 0.10	W ± 0.20	E ± 0.10	F ± 0.05	P1 ± 0.10	P2 ± 0.05	PO ± 0.10	DO+0.10/0	t1 ± 0.05	t2 ± 0.10	Standard packaging quantity
B	3.30	3.80	8.00	1.75	3.50	4.00	2.00	4.00	$\phi 1.50$	0.25	2.20	2,000 pcs

REEL DIMENSIONS

