

# Magnetic Pattern Recognition Sensors



## Standard Compact Type

### BS05C/N Series

#### ■ Features (BS05C Series)

1. High sensitivity and excellent gap characteristics
2. Output voltage is independent of scanning speed.
3. Compact size and light weight make them ideal for downsizing.
4. Longer product life is given to BS05C series with a specially hard metal cover.
5. BS05C1HGCA has superior noise immunity against induced noise originating from motors and transformers.

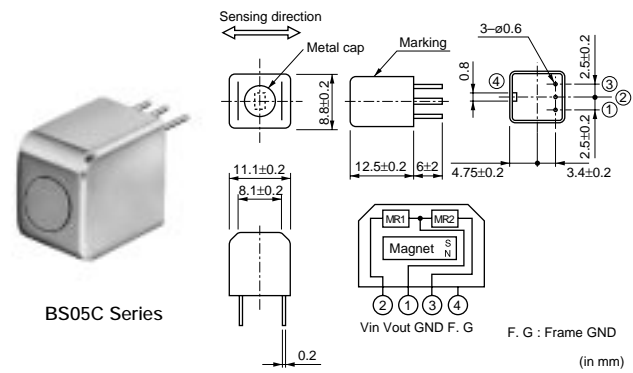

BS05C Series

#### ■ Applications

1. Bank note validator
2. Magnetic ink document reader
3. Magnetic card reader
4. Magnetic gear detector

#### ■ Features (BS05N Series)

1. High sensitivity and excellent gap characteristics
2. Output voltage is independent of scanning speed.
3. Compact size and light weight make them ideal for downsizing.
4. High reliability by sealing structure
5. BS05N1HGAA has superior noise immunity against induced noise originating from motors and transformers.
6. BS05N1NFAA has wider detection width of 6mm.

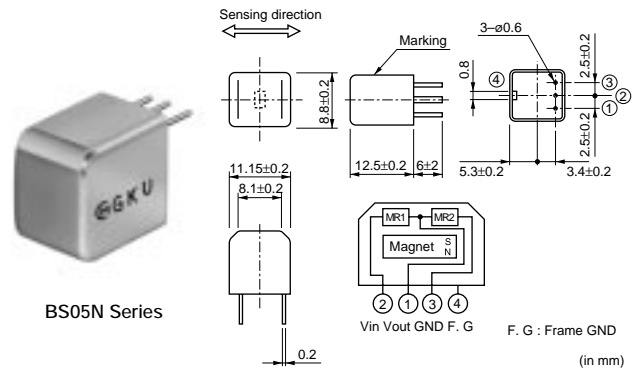

BS05N Series

#### ■ Applications

1. Bank note validator
2. Magnetic ink document reader
3. Magnetic card reader
4. Magnetic gear detector

Part Number	Supply Voltage (V)	Total Resistance (k ohm)	Output Voltage (mVrms)	Test Method	Detection Width (mm)	Resolution (mm)	Operating Temperature Range (°C)
BS05C1HFAA	5	0.5 to 4	400 min.	Test Method A	3	0.75	-20 to 60
BS05C1HGCA	5	0.5 to 4	235 to 405	Test Method A	3	0.75	-20 to 60
BS05N1HFAA	5	0.5 to 4	400 min.	Test Method A	3	0.75	-20 to 60
BS05N1HGAA	5	0.5 to 4	235 to 405	Test Method A	3	0.75	-20 to 60
BS05N1NFAA	5	0.6 to 6	330 min.	Test Method B	6	0.87	-20 to 60



1

## BS05T Series

### ■ Features

1. High sensitivity and excellent gap characteristics
2. Output voltage is independent of scanning speed.
3. Compact size and light weight make them ideal for downsizing.
4. Higher in cost performance
5. Superior noise immunity against induced noise originating from motors and transformers.

### ■ Applications

1. Bank note validator
2. Magnetic ink document reader

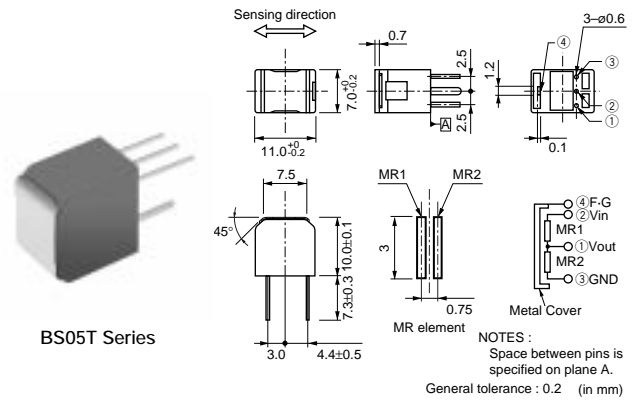

Part Number	Supply Voltage (V)	Total Resistance (k ohm)	Output Voltage (mVrms)	Test Method	Detection Width (mm)	Resolution (mm)	Operating Temperature Range (°C)
BS05T1HGNA	5	1 to 6	200 to 400	Test Method B	3	0.75	-20 to 60

### ■ Test Method A

1. Amplifier's gain is set to 1,100 at the frequency of 60 Hz.  
Fig. 1 shows the detail of amplifier.
2. DUT is set in the test fixture as shown in Fig. 2.
3. AC current of 100mArms is applied to the copper wire.
4. Amplifier's output voltage is read with DMM while DUT is slowly moved along the guide rail.

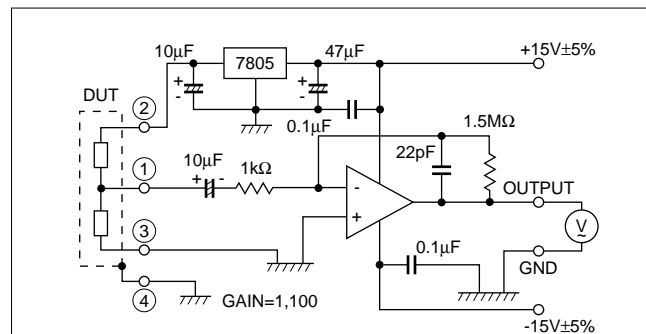

Fig. 1 Amplifier for Output Voltage Measurement

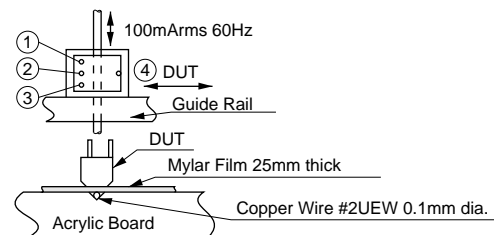

Fig. 2 Test Fixture for Output Voltage Measurement

Continued on the following page.

Continued from the preceding page.

■ Test Method B

1. Amplifier's gain is set to 1,100 at the frequency of 60 Hz.
- Fig. 1 shows the detail of amplifier.
2. DUT is set in the test fixture as shown in Fig. 2.
3. AC current of 100mA rms is applied to the copper wire.
4. Amplifier's output voltage is read with DMM while DUT is slowly moved along the guide rail.

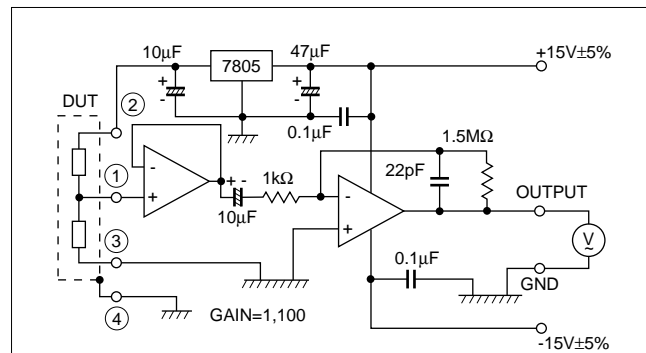

Fig. 1 Amplifier for Output Voltage Measurement

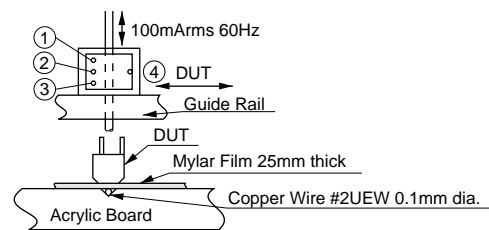

Fig. 2 Test Fixture for Output Voltage Measurement

1

# Magnetic Pattern Recognition Sensors



## Wide Sensing Element Type

2

### ■ Features

1. Wide MR element covering extensive area allows increased tolerance for scanning and can accept a variety of bank notes.
2. Long product life achieved by an extremely hard metal cover is ideal for use in high speed ATM and bank note counters.
3. High sensitivity and excellent gap characteristics
4. Output voltage is independent of scanning speed.
5. BS05W1KFAB is ideal for use in high-speed process machines such as ATM and bank note counters because an extremely hard metal cover is used.

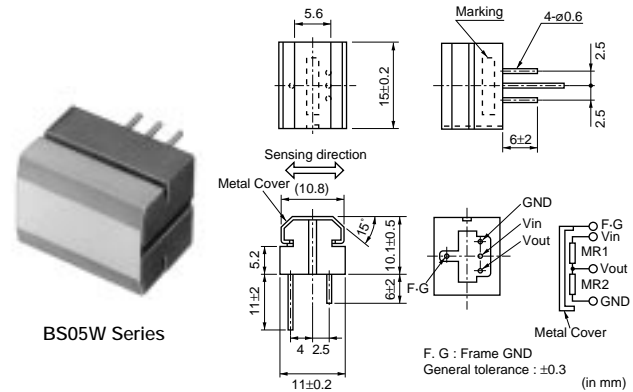

### ■ Applications

1. Bank note validator
2. Magnetic ink document reader

Part Number	Supply Voltage (V)	Total Resistance (k ohm)	Output Voltage (mVp-p)	Test Method	Detection Width (mm)	Resolution (mm)	Operating Temperature Range (°C)
BS05W1KFAA	5	1 to 15	0.3 to 0.8	Test Method C	10	0.75	-20 to 60
BS05W1KFAB	5	1 to 15	0.3 to 0.8	Test Method C	10	0.75	-20 to 60

### ■ Test Method C

1. Output voltage is measured by using the magnetic pattern card. The magnetic pattern card has the same magnetic density of 1000 letters on 1000 yen bank notes.
2. Drive the magnetic pattern card and record output voltage Vp-p with X-Y recorder.

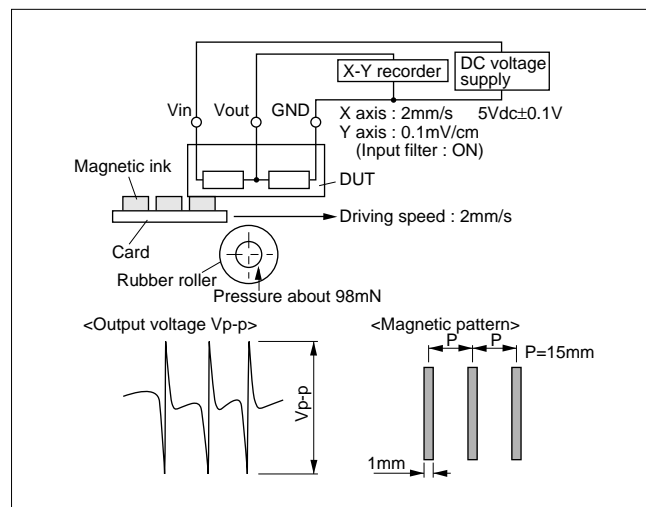

# Magnetic Pattern Recognition Sensors



## Multi-channel Type

### ■ Features

1. High sensitivity and excellent gap characteristics
2. Output voltage is independent of scanning speed.
3. Compact size and light weight make them ideal for downsizing.
4. Simple and quick mounting is possible due to one single holder for multiple MR elements.
5. BS05M1KFCA, BS05M1KGCA have detection width of 60mm, without non-detection area.
6. BS05M1KFBA, BS05M1KFBB have detection width of 130mm, without non-detection area.
7. BS05M1KGCA has superior noise immunity against induced noise originating from motors and transformers.

### ■ Applications

1. Bank note validator
2. Magnetic ink document reader
3. Magnetic card reader



BS05M1HFAL

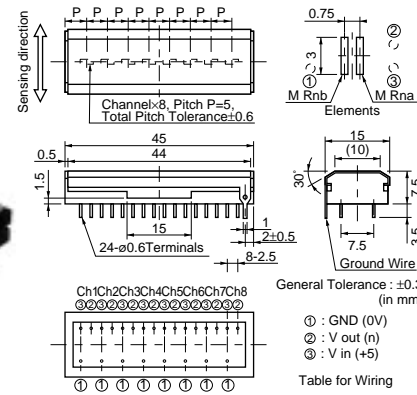

BS05M1KFBA

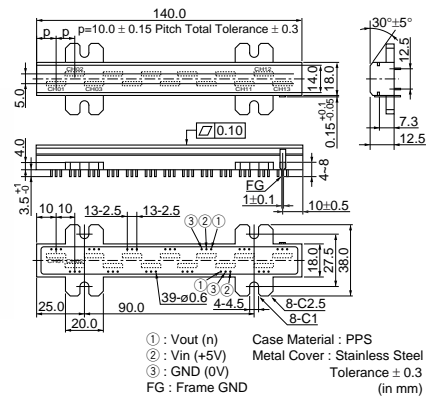

BS05M1KFBB

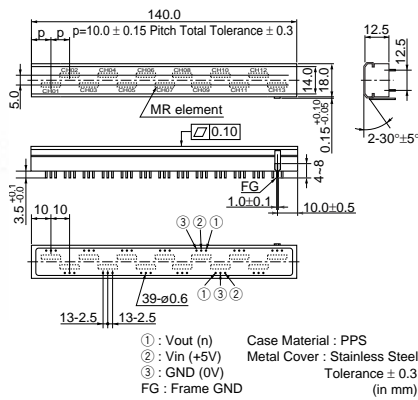

BS05M1KFCA/BS05M1KGCA

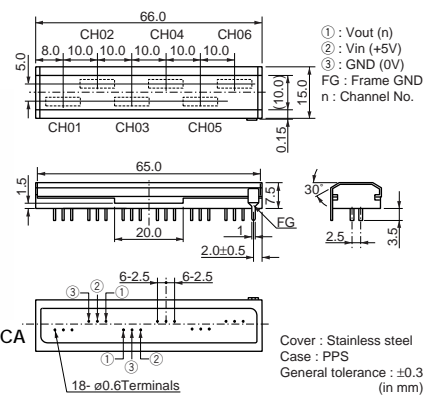

Part Number	Supply Voltage (V)	Total Resistance (k ohm)	Output Voltage (mVrms)	Test Method	Detection Width (mm)	Resolution (mm)	Operating Temperature Range (°C)
BS05M1HFAL	5	0.5 to 6	150 min.	Test Method D	3 x 8ch	0.75	0 to 50
BS05M1KFBA	5	1 to 5	350 min.	Test Method E	10 x 13ch	0.75	0 to 50
BS05M1KFBB	5	1 to 5	350 min.	Test Method E	10 x 13ch	0.75	0 to 50
BS05M1KFCA	5	1 to 6	300 min.	Test Method E	10 x 6ch	0.75	0 to 50
BS05M1KGCA	5	0.5 to 6	150 min.	Test Method E	10 x 6ch	0.75	0 to 50

3

### ■ Test Method D

1. Amplifier's gain is set to 70dB at the frequency of 500Hz.  
Fig. 1 shows details of amplifier.
2. DUT is set in the test fixture as shown in Fig. 2.
3. AC current of 100mArms is applied to the copper wire.
4. Amplifier's output voltage is read with DMM while DUT is slowly moved along the guide rail.

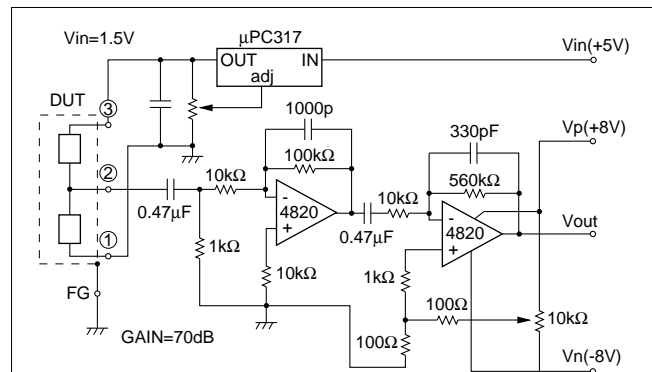

Fig. 1 Amplifier for Output Voltage Measurement

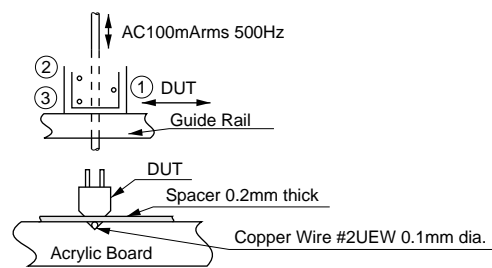

Fig. 2 Test Fixture for Output Voltage Measurement

3

### ■ Test Method E

1. Amplifier's gain is set to 1,100 at the frequency of 60 Hz.  
Fig. 1 shows details of amplifier.
2. DUT is set in the test fixture as shown in Fig. 2.
3. AC current of 100mA (rms) is applied to the copper wire.
4. Amplifier's output voltage is read with DMM while DUT is slowly moved along the guide rail.

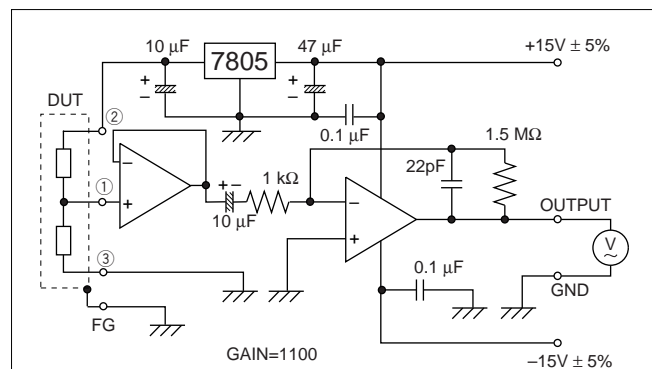

Fig. 1 Amplifier for Output Voltage Measurement

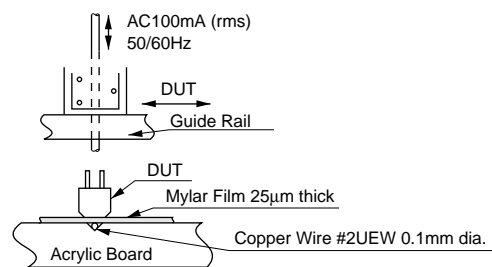

Fig. 2 Test Fixture for Output Voltage Measurement

## ⚠Caution/Notice

### ■ ⚠Caution (Handling)

1. This sensor generates very strong suction because this product contains a permanent magnet. Be careful not to apply mechanical shock when handling the sensor.
2. Do not place this product near magnetic recording media such as magnetic tapes or floppy disks. Magnetic recording could be damaged.
3. Do not place this product near a person who has an electronic medical device. It is very dangerous and may cause malfunction of an electronic medical device.

### ■ Notice (Storage and Operating Condition)

1. Please avoid water, chemical solvent or oil.
2. Please avoid corrosive gas (Chlorine gas, Hydrogen sulfide gas, Ammonia gas, Nitric oxide gas, etc.).
3. Please avoid airborne particles.
4. Please avoid strong vibration or shock.
5. Ambient temperature change should be within 1 deg. C/min.

### ■ Notice (Rating)

1. This product is designed to detect magnetic properties of banknotes. Please contact us when using this product to detect any magnetic properties other than of banknotes.
2. Because this product contains a permanent magnet, magnetic signals in writable magnetic cards, such as train tickets or pre-paid cards could be damaged. Please consult with us before using in such circumstances.
3. BS05M1 series:  
To avoid unusual wear of the metal cover or jamming of the banknote, around 0.1mm gap between the sensor and the opposite mechanisms such as rollers is recommended to reduce the load on the metal cover. A load of 0N is recommended.

4. BS05N series, BS05C series, BS05W series:  
Please do not apply excessive force or shock on the sensing side. When adhering the target media on the sensing side, please give the same level of load throughout the sensor surface and the load should be less than 0.49N.  
When a roller is set over the sensor, it should be cylindrical shape and its diameter greater than the width of the sensor.  
If the area coming in contact with the sensor is smaller, the surface will be partially worn and lead to trouble.
5. Please mount this product with holder stuck firmly on the PCB in addition to solder terminals.

### ■ Notice (Soldering and Mounting)

1. Excessive force or shock to the product should be avoided, especially to the metal cover.
2. Do not place the product near magnets, moving ferromagnetic materials, parts which generate magnetic fields.
3. Do not place the product near high voltage lines or high current lines.
4. Do not apply excessive force, rotate or bend the terminal.
5. Wiring should be avoided while voltage supply is active.

6. Hand soldering should be applied. Soldering should be done in following conditions:  
Soldering Temperature:  
350+/-10 deg. C less than 3 seconds  
or 260+/-5 deg. C less than 10 seconds.
7. Flux should be rosin with a chlorine content of no more than 0.2wt%.
8. Flux cleaning should be done by hand brushing.
9. Prevent the flux cleaning solvent from splashing on the product.

## Reference Data

### ■ Construction

Magnetic pattern recognition sensor consists of a pair of magnetoresistive (MR) elements and a magnet.

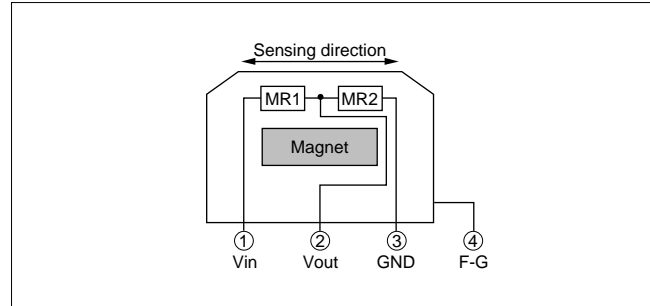

### ■ Magnetoresistive Effect

A change in the resistance of a ferromagnetic or semiconductive material when it is subjected to magnetic flux is illustrated in the diagram. Murata's sensor uses InSb, which exhibits a very high magnetoresistive effect.

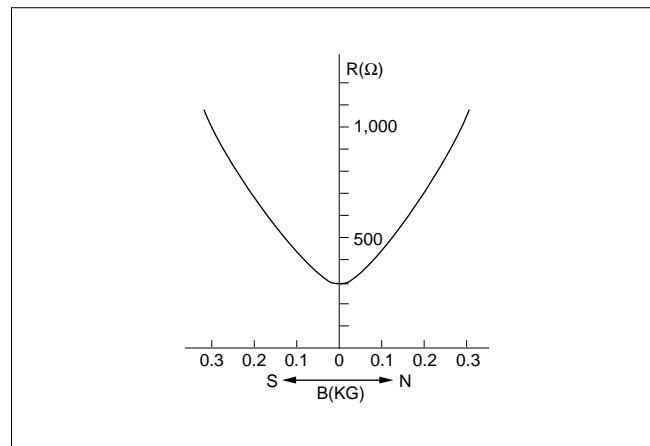

### ■ Principle of Operation

When a material printed with magnetic ink is scanned over the sensor, the magnetic flux applied to MR1 and MR2 changes. Thus, the sensor generates signals as indicated below.

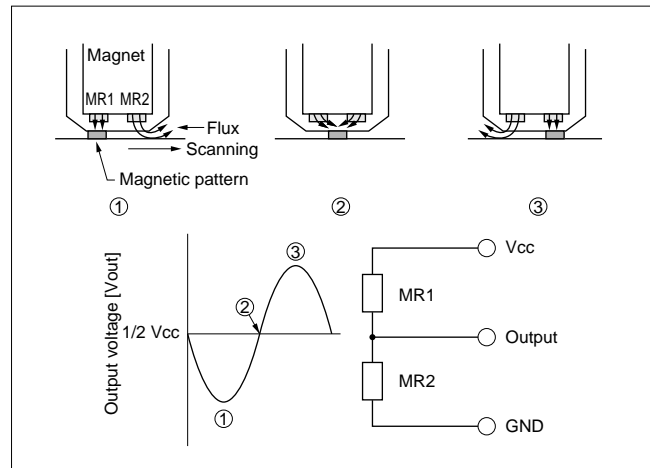

### ■ Typical Application

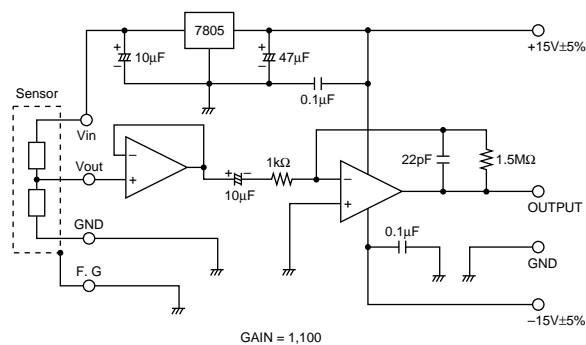



## ISO 9000 Certifications/Part Numbering

Manufacturer's of the products in this catalog have obtained the ISO 9000 quality system certificate.

Plant	Certified Date	Organization	Registration No.
Kanazawa Murata Mfg. Co., Ltd. Includes Nishikanazawa factory	Nov. 25,1992	Reliability Center for Electronic Components of Japan	RCJ-92M-10

● Part Numbering

Magnetic Pattern Recognition Sensors

(Part Number)    BS 05W 1KFAB  

1  
 2  
 3  
 4

- ① Product ID
- ② Type
- ③ Characteristics
- ④ Individual Specification Code

\* "(Part Number)" shows only an example which might be different from actual part number.

\* Any other definitions than "① Product ID" might have different digit number from actual part number.

**⚠Note:**

1. Export Control

〈For customers outside Japan〉

No muRata products should be used or sold, through any channels, for use in the design, development, production, utilization, maintenance or operation of, or otherwise contribution to (1) any weapons (Weapons of Mass Destruction (nuclear, chemical or biological weapons or missiles) or conventional weapons) or (2) goods or systems specially designed or intended for military end-use or utilization by military end-users.

〈For customers in Japan〉

For products which are controlled items subject to the "Foreign Exchange and Foreign Trade Law" of Japan, the export license specified by the law is required for export.

2. Please contact our sales representatives or product engineers before using the products in this catalog for the applications listed below, which require especially high reliability for the prevention of defects which might directly damage a third party's life, body or property, or when one of our products is intended for use in applications other than those specified in this catalog.

- |                             |  |
|-----------------------------|--|
| ① Aircraft equipment        | ② Aerospace equipment  |
| ③ Undersea equipment        | ④ Power plant equipment  |
| ⑤ Medical equipment         | ⑥ Transportation equipment (vehicles, trains, ships, etc.)   |
| ⑦ Traffic signal equipment  | ⑧ Disaster prevention / crime prevention equipment   |
| ⑨ Data-processing equipment | ⑩ Application of similar complexity and/or reliability requirements to the applications listed above |

3. Product specifications in this catalog are as of July 2004. They are subject to change or our products in it may be discontinued without advance notice. Please check with our sales representatives or product engineers before ordering. If there are any questions, please contact our sales representatives or product engineers.

4. Please read rating and ⚠CAUTION (for storage, operating, rating, soldering, mounting and handling) in this catalog to prevent smoking and/or burning, etc.

5. This catalog has only typical specifications because there is no space for detailed specifications. Therefore, please approve our product specifications or transact the approval sheet for product specifications before ordering.

6. Please note that unless otherwise specified, we shall assume no responsibility whatsoever for any conflict or dispute that may occur in connection with the effect of our and/or a third party's intellectual property rights and other related rights in consideration of your use of our products and/or information described or contained in our catalogs. In this connection, no representation shall be made to the effect that any third parties are authorized to use the rights mentioned above under licenses without our consent.

7. No ozone depleting substances (ODS) under the Montreal Protocol are used in our manufacturing process.



<http://www.murata.com/>

**Head Office**  
1-10-1, Higashi Kotari, Nagaokakyo-shi, Kyoto 617-8555, Japan  
Phone: 81-75-951-9111

**International Division**  
3-29-12, Shibuya, Shibuya-ku, Tokyo 150-0002, Japan  
Phone: 81-3-5469-6123 Fax: 81-3-5469-6155 E-mail: intl@murata.co.jp