

QUICK START GUIDE FOR DEMONSTRATION CIRCUIT 855 PHOTOFLASH CHARGER

LT3484EDCB-0/LT3484EDCB-1/LT3484EDCB-2

DESCRIPTION

Demonstration circuit 855 is a Photoflash Charger featuring the LT3484EDCB-0, LT3484EDCB-1, and LT3484EDCB-2. It demonstrates a complete photoflash application, including the photoflash capacitor, flash tube and trigger circuit. An on-board microcontroller generates the necessary signals to produce an on-demand flash, red-eye sequence, and flash capacitor refresh.

The demonstration board comes in three variants. DC855A-A uses the LT3484EDCB-0, while DC855A-B and DC855A-C use the LT3484EDCB-1 and LT3484EDCB-2, respectively.

The LT3484 family of photoflash capacitor ICs is designed for use in a digital camera and mobile phone applications where space is a premium. The LT3484's patented control technique allows it to use extremely small transformers, and the improved NPN power switch re-

quires no external Schottky diode clamp, reducing the solution size. The output voltage detection requires no external circuitry as the transformer turns ratio determines the final charger voltage.

The device features a V_{BAT} pin, which allows the use of 2 alkaline cells to charge the capacitor. The CHARGE pin gives full control of the part to the user. Driving CHARGE low shuts the part down.

WARNING! Lethal voltages are present on the DC855 circuit board. Do not operate the assembly unless you are trained to handle high voltage circuits.

Design files for this circuit board are available. Call the LTC factory.

 , LTC and LT are registered trademarks of Linear Technology Corporation.

Table 1. Performance Summary ($T_A = 25^\circ\text{C}$)

PARAMETER	CONDITION	VALUE
Minimum V_{BAT} Voltage	$V_{IN} = 2.8\text{V} - 4.2\text{V}$	1.8VDC
Maximum V_{BAT} Voltage	$V_{IN} = 2.8\text{V} - 4.2\text{V}$	4.2VDC
Minimum V_{IN} Voltage	$V_{BAT} = 1.8\text{V} - 4.2\text{V}$	2.8VDC
Maximum V_{IN} Voltage	$V_{BAT} = 1.8\text{V} - 4.2\text{V}$	4.2VDC
Output Voltage	$V_{IN} = 2.8\text{V} - 4.2\text{V}$, $V_{BAT} = 1.8\text{V} - 4.2\text{V}$	320VDC, typical
Average input current	DC855A-A, LT3484-0	500mA, typical
	DC855A-C, LT3484-2	350mA, typical
	DC855A-B, LT3484-1	225mA, typical

OPERATING PRINCIPLES

The theory of operation of the LT3484 and xenon flash tube illumination has been discussed at length in the LT3484 data sheet and the Linear Technology Application Note AN95, respectively. The reader is referred to these documents, available online at <http://www.linear.com>.

QUICK START PROCEDURE

WARNING! Lethal voltages are present on the DC855 circuit board. Do not operate the assembly unless you are trained to handle high voltage circuits.

Demonstration circuit 855 is easy to set up to evaluate the performance of the LT3484EDCB-0, LT3484EDCB-1, and LT3484EDCB-2. Refer to Figure 1 for proper measurement equipment setup and follow the procedure below:

1. Set the jumper at JP1 across the DAT and MCLR pins.
2. With the power supply disconnected from DC855, set the VBAT voltage between 1.8V to 4.2V. Set the VIN voltage between 2.8V and 4.2V. Turn off the power supply.
3. Connect the power supply to DC855, referring to the connection diagram given in Figure 1.
4. Turn on the power supply, verifying that the VIN and VBAT voltages are correctly set.
5. Press the ON/OFF button once. The READY/CHARGE LED should glow red while charging the output capacitor and then glow green.
6. To flash the xenon tube, verify that the READY/CHARGE LED is green. Avoid looking directly at the xenon flash tube and press the FLASH button once. After the tube flashes, the READY/CHARGE LED should turn red as the LT3484 replenishes the charge in the flash capacitor.
7. To generate a red-eye sequence, verify that the READY/CHARGE LED is green. Avoid looking di-

rectly at the xenon flash tube and press the REDEYE button once. After the flash sequence is over, the READY/CHARGE LED should turn red as the LT3484 replenishes the charge in the flash capacitor.

8. When finished testing, press the ON/OFF switch once. This flashes the xenon tube, discharging the flash capacitor and shuts down the LT3484. The output capacitor is not completely discharge when this operation is complete. 50V or more may be left on the capacitor, so the user is cautioned to avoid physical contact with the flash tube circuitry at all times. The flash tube circuitry consists of D1, C2, R3, R10, C3, T2, FT1, and Q1.
9. Monitor the DONE, CHARGE and TRIGGER bits by using the provided test points. Do not make measurements from under the protective cover.
10. The on-board microcontroller may be disabled by removing the VIN and VBAT voltages and moving the JP1 jumper to short the GND and CLK pins. The user can charge the output capacitor and activate the flash tube by applying the appropriate signals to the CHARGE and TRIGGER test points. The timing can be validated by monitoring these and the DONE signal. Please refer to the LT3484 data sheet for detailed signal requirements.

ADDITIONAL NOTES

It is assumed that DC855A will be tested with power provided from an external source, such as a lab bench supply. Under such an operating condition, the wire

QUICK START GUIDE FOR DEMONSTRATION CIRCUIT 855 PHOTOFLASH CHARGER

length between the DC855A board and the power supply terminals can be several feet and the line loss may be excessive. For this reason, CIN has been added to the board at the input terminals to attenuate the ground shifting associated with pulling the main switch current through the wires connecting to the power supply. This capacitor would generally not be required in a battery powered portable application, where the battery would be physically located close to the LT3484 and the impedance of the connection is low.

The flashtube for this reference design is a FTA160709, manufactured by Perkin-Elmer. They can be contacted at:

PerkinElmer Optoelectronics
Lithography and Lighting
1300 Optical Drive
Azusa, CA. 91702

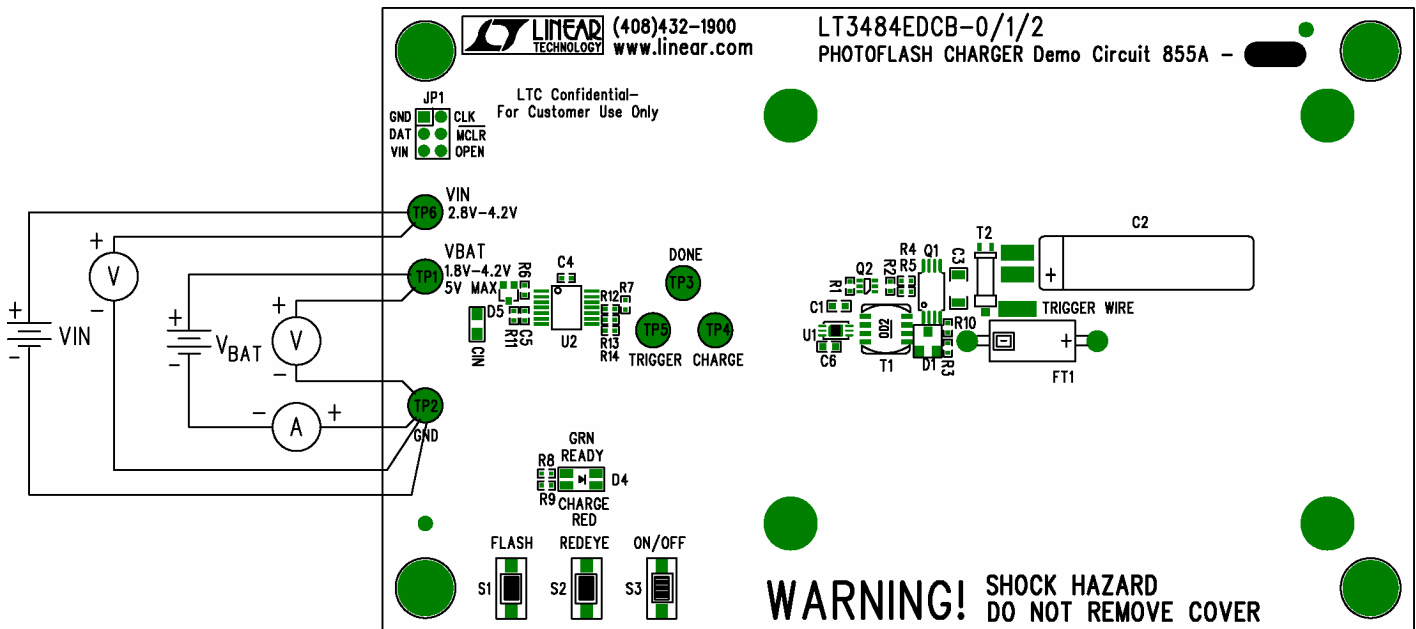
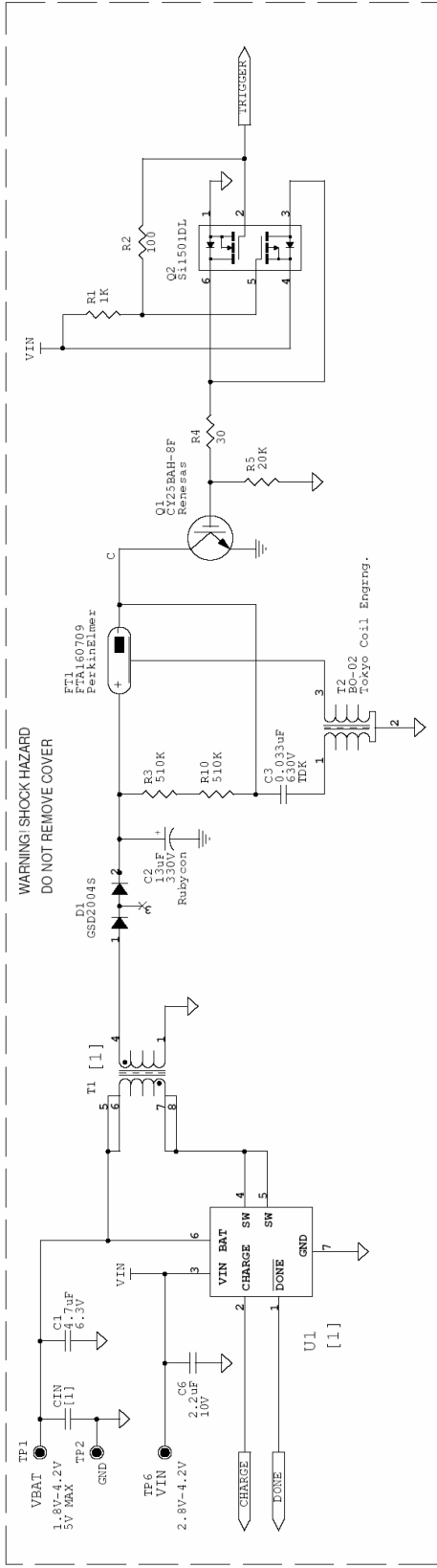

Figure 1. Proper Measurement Equipment Setup

QUICK START GUIDE FOR DEMONSTRATION CIRCUIT 855 PHOTOFLASH CHARGER

REVISION HISTORY				
ECO	REV	DESCRIPTION	DATE	APPROVED
	3	PROTO	08/20/05	

This circuit is proprietary to Linear Technology and supplied for use with Linear Technology parts.
Customer Notice: Linear Technology has made a best effort to design a circuit that meets customer-supplied specifications; however, it remains the customer's responsibility to verify proper and reliable operation in the actual application. Component selection, component quality, and manufacturing process can all affect circuit performance or reliability. Contact Linear Applications Engineering for assistance.



**WARNING: SHOCK HAZARD
DO NOT REMOVE COVER**

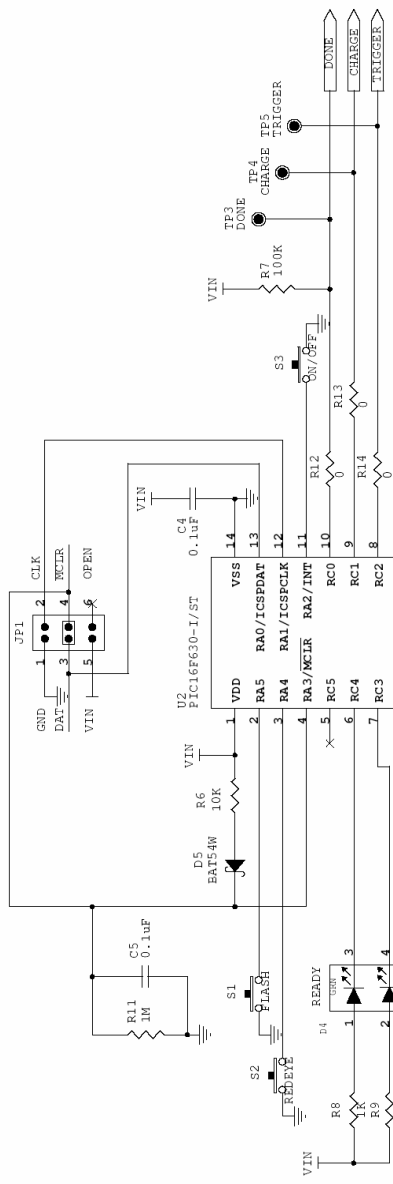

CONTRACT NO.		DATE	
APPROVALS		11/02/04	
DRAWN MEI	CHECKED	APPROVED	DESIGNER
ENGINEER	DESIGNER	SIZE	CAGE CODE
Custom	DWG NO	DC855A	REV
3	3	3	3

TITLE		SCH, LT13484EDCB-012, PHOTOFLASH CHARGER	
SCALE		855A-3.DSN	
SHEET		1 OF 1	

VERSION	U1	T1 (TDK)	CIN
-A	LT3484EDCB-0	LDT565630T-001	CAP, 0805 10uF 20% 6.3V X5R
-B	LT3484EDCB-1	LDT565630T-002	CAP, 0805 4.7uF 10% 6.3V X5R
-C	LT3484EDCB-2	LDT565630T-003	CAP, 0805 10uF 20% 6.3V X5R

Monday, June 27, 2005