

DESCRIPTION

Demonstration circuit 530A-A and 530A-B are complete constant-current/constant-voltage battery chargers designed to charge one Lithium-Ion cell. Both feature the LTC4050 Linear Battery Charger driving a P-channel MOSFET in a series pass linear regulator configuration for charging at a maximum current of 700mA (limited by the power dissipation capabilities of the pass transistor).

Demo board LTC4050A-A features the LTC4050-4.1, which has a recharge threshold voltage of 3.88V, making it suitable for charging 4.1V cells.

Demo board LTC4050A-B features the LTC4050-4.2, which is recommended only for charging a 4.2V cell, due to its recharge threshold voltage of 3.98V.

Other Features include:

- Preset float voltages of 4.1 and 4.2V $\pm 1\%$
- 700mA Constant Current (can be programmed for other charge currents)
- 3-hour charge termination timer. This timer can be set for other time periods through a capacitor change. For instance, you may want to use a much shorter period (on the order of 30 seconds) when evaluating the

board with a battery simulator instead of a Li-Ion battery.

- Manual Shutdown
- C/10 Trickle charge for deeply discharged batteries
- Auto recharge when battery voltage drops below pre-set threshold (3.88V for DC530A-A and 3.98V for DC530A-B).
- Low battery drain current when the input supply is removed
- Input Power OK LED indicator (ACPR)
- C/10 Charge LED indicator (CHRG)
- NTC Input to prevent charging if the battery is too hot or too cold

Small surface mount components are used to minimize board space and height with the circuitry occupying approximately 0.15 square inches of board space with a height of 0.054 inches (1.4mm).

Design files for this circuit board are available. Call the LTC factory.

Table 1. Performance Summary

| PARAMETER | VALUE |
|--|---|
| Input Voltage Range | 4.5V to 6.0V (upper range limited by MOSFET dissipation) |
| Output Voltage V_{BAT} (constant voltage mode) | 4.1V $\pm 1\%$ DC530A-A 4.2V $\pm 1\%$ DC530A-B |
| Output Current I_{BAT} (constant current mode) | 700mA $\pm 8\%$ |
| Output Current I_{BAT} (trickle current mode) | 70mA $\pm 70\%$ |
| C/10 CHRG LED Threshold Level | 35-140mA |
| Trickle Charge Threshold Voltage | 2.49V |
| Battery Drain Current with V_{IN} Removed | 5 μ A Note: If V_{IN} is pulled down to 0V, the current drain from the battery will be higher due to the leakage current of the input Schottky diode. A silicon diode could be used for the input diode if the slightly greater forward voltage drop is not a problem. |

QUICK START PROCEDURE

Demonstration circuits 530A-A and 530A-B are easy to set up to evaluate the performance of the LTC4050. Refer to Figure 1 for proper measurement equipment setup and follow the procedure below:

1. Install jumper JP1 in the PROG position to enable the charger.
2. Set the input power supply to 0V, and then connect it to the VIN and GND pins of the demo board.
3. Set the battery simulator to 0V, and then connect it to the BAT and GND pins.
4. Connect the digital voltmeters as shown in the setup diagram to measure VIN, charger voltage (VBAT) and the charge current (IBAT).
5. Start the demo board evaluation by increasing the input power supply to approximately 3.8V (battery simulator power supply set for 0V). The charger output voltage and charge current should be 0. The CHRG and ACPR LEDs should be off. **The charger is off due to the undervoltage lockout feature.**
6. Increase the input voltage to 5V and keep the battery simulator power supply at 0V. Both LEDs (CHRG and ACPR) should now be on, the charger output voltage (VBAT) should be approximately 140mV, and the charge current should be approximately 70mA. **This is the trickle charge mode for a deeply discharged battery.** Typically, a battery that has not been charged for a long time.
7. Starting from 0V, slowly increase the battery simulator power supply (VBAT), observing the charger's output voltage on the DVM. When the charger's output voltage exceeds approximately 2.5V, the charger will suddenly enter the Constant current portion of the charge cycle resulting in an abrupt increase in charge current (IBAT) to the programmed value of approximately 700mA. **This is the constant current mode.**
8. Continue slowly increasing the battery simulator power supply, thus simulating a battery accepting charge. The charge current should remain at the programmed value of 700mA until the charger output voltage is within approximately 10mV of the preset charge voltage, at which time the charge current will begin to decrease. **This is the beginning of the constant voltage portion of the charge cycle.**
9. Continue slowly increasing the battery simulator power supply until the charge current drops to approximately 200mA, and then read the charger output voltage. **This reading is the charger float voltage (VBAT) which will be either 4.1V or 4.2V ± 40mV depending on the demo board version.**
10. Place jumper JP1 in the SHDN position. The charger will shut down, dropping the charge current to 0mA. The ACPR LED remains on and the charge LED goes out.
11. Return JP1 to the PROG position.
12. Continue slowly increasing the battery simulator power supply while observing the CHRG LED. The LED will go out when the charge current drops to approximately 10% of the programmed charge current of 700mA. **This verifies that the C/10 output is operating correctly.**

The current through the LED drops from approximately 10mA when the LED is on, to approximately 30μA when the charge current drops to 10%, and drops to 0μA after the timer has timed out (3 hours when a 0.1μF timing capacitor is used).

At C/10, when the CHRG LED goes out, the battery is approximately 94% charged. The charger will continue charging for a total of 3 hours (0.1μF timing capacitor) and then stop, at which point the battery is approximately 99% charged.

NOTE: For evaluation purposes, the time can be decreased from the programmed 3 hours to approximately 30 seconds by reducing the timer capacitor (C3) from 0.1μF to 270pF.
13. After the timer has timed out, slowly decrease the battery simulator power supply. At approximately 3.88V for demo board DC530A-A, a new 700mA charge cycle begins. With demo board DC530A-B,

QUICK START GUIDE FOR DEMO CIRCUITS 530A-A AND 530A-B LI-ION BATTERY CHARGER

this should occur at approximately 3.98V. **This is the Recharge Threshold Voltage.**

14. To verify battery drain current, remove the input supply voltage, and set the battery simulator power supply to approximately 4V. **The charge current DVM will now read battery drain current.**

If V_{IN} is pulled down to 0V, the current drain from the battery will be higher due to the leakage current of the input Schottky diode. A silicon diode could be used

for the input diode if the slightly greater forward voltage drop is not a problem.

15. Operation of the NTC function is verified as follows. Placing a 5k resistor from the NTC pin to GND can simulate too hot operation. In order to verify too cold operation R7 has to be removed and replaced by a 33k resistor. While charging is inhibited by an out of spec NTC both the CHRG and ACPR LEDs will be ON.

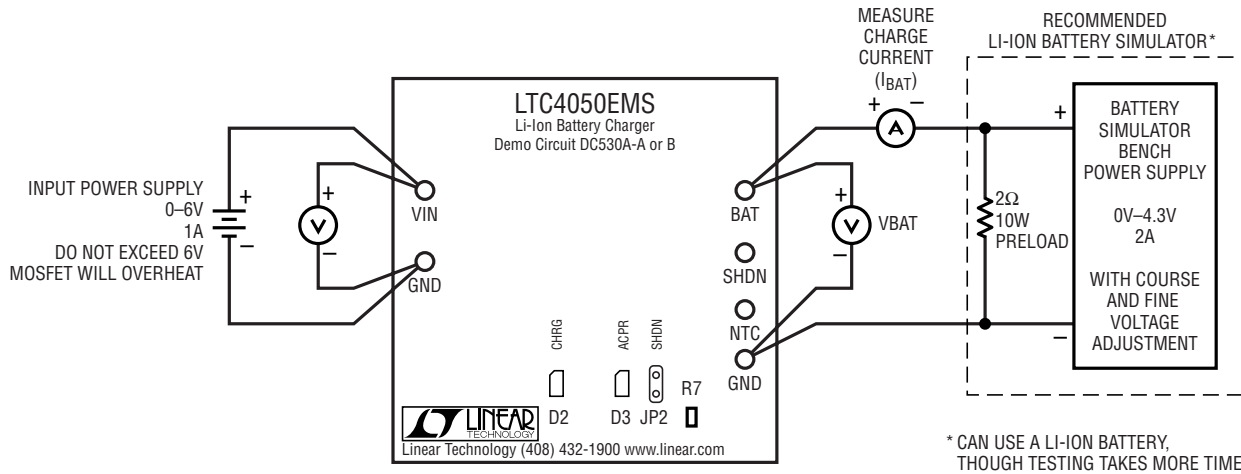

Figure 1. Proper Measurement Equipment Setup

NOTE: Although it would take more time, this charger can also be evaluated using a rechargeable Li-Ion battery in place of the battery simulator pictured here. If you use a real battery, keep the DC resistance between the charger and the battery to a minimum, as this will affect the charge current in the constant voltage mode.

QUICK START GUIDE FOR DEMO CIRCUITS 530A-A AND 530A-B L-ION BATTERY CHARGER

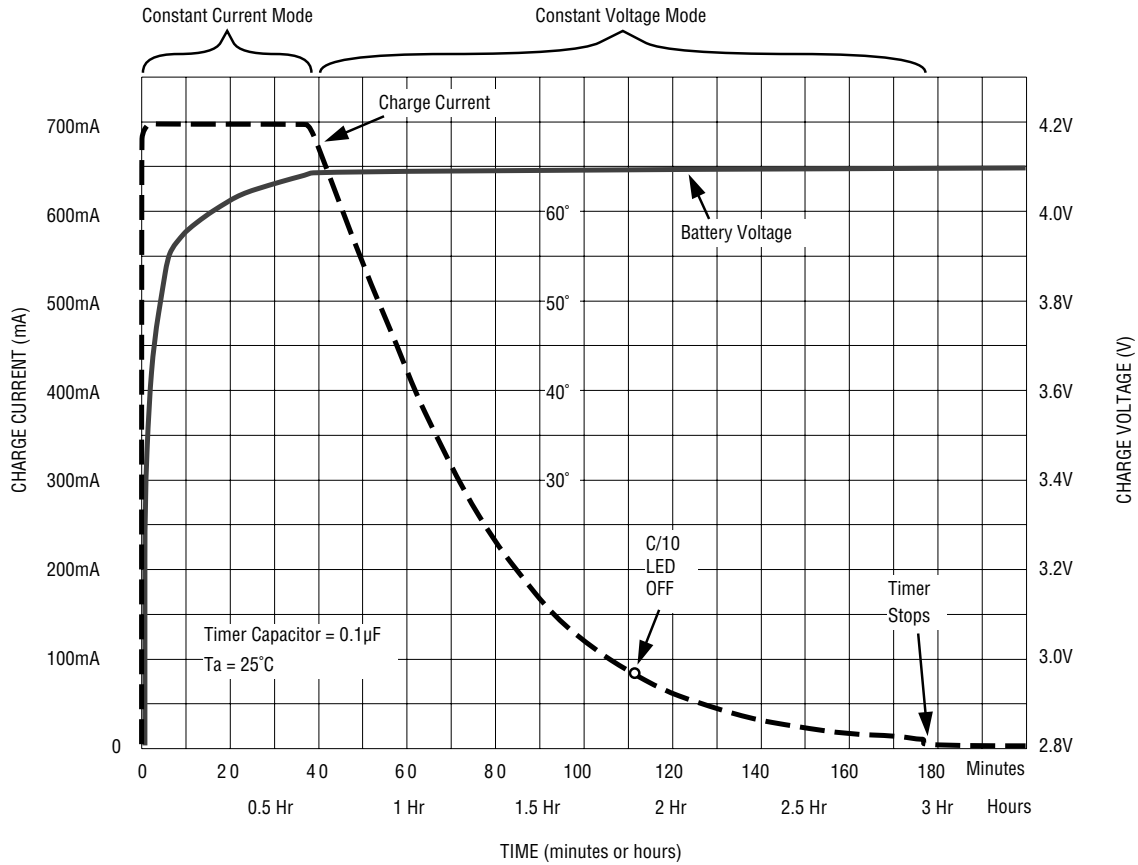
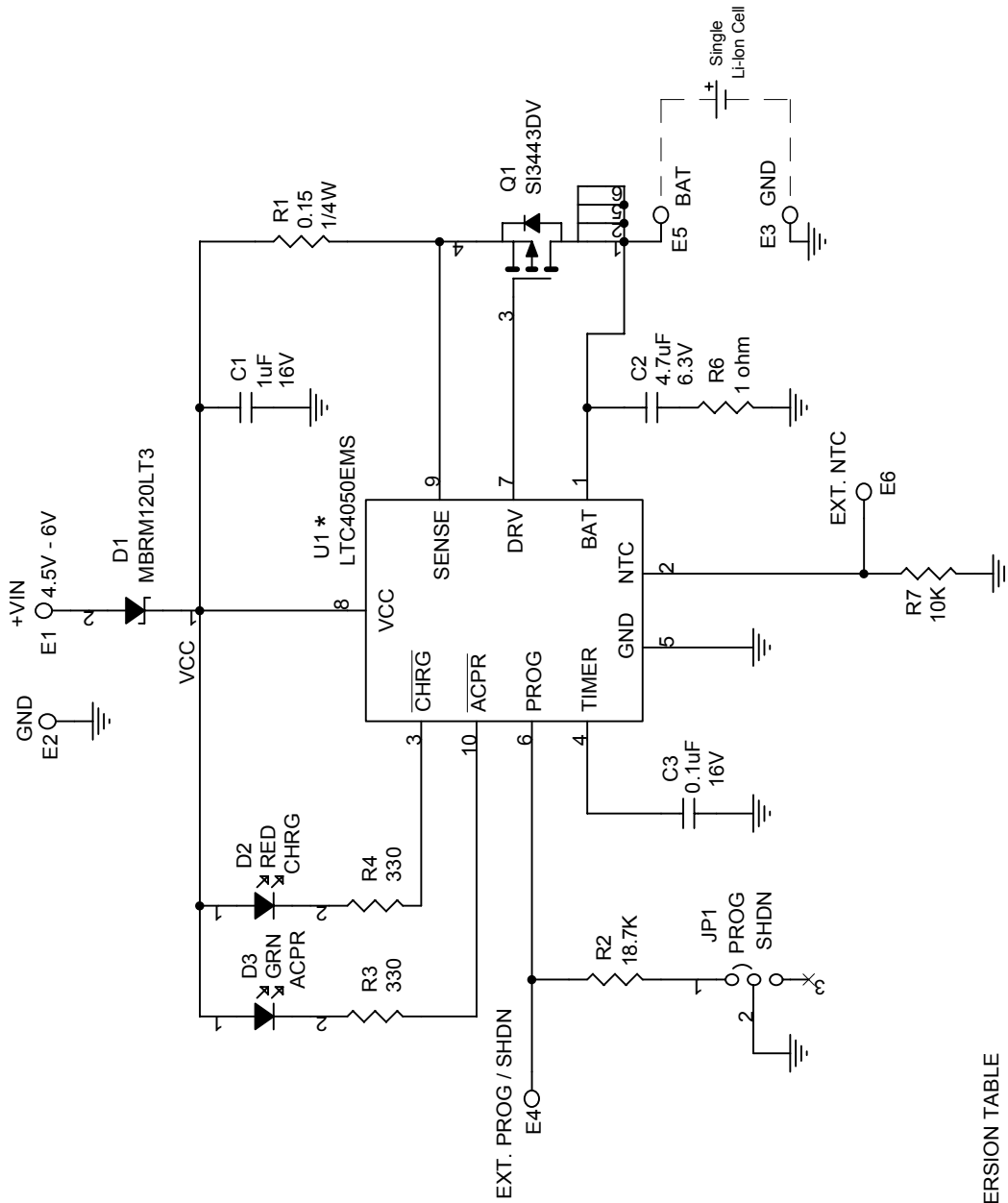

Figure 2. Typical Charge Cycle Using DC530A-A



* VERSION TABLE

| VERSION | Battery Voltages | U1 |
|----------|------------------|----------------|
| DC530A-A | 4.1V | LTC4050EMS-4.1 |
| DC530A-B | 4.2V | LTC4050EMS-4.2 |

| | | | |
|------------------------|---------|---|-----------|
| CONTRACT NO. | | 1630 McCarthy Blvd. Milpitas, CA 95035 Phone: (408)432-1900 Fax: (408)434-0507 | |
| APPROVALS | DATE | TITLE | |
| DRAWN June Wu | 4/30/02 | LTC4050EMS, Li-Ion Battery Charger with NTC | |
| CHECKED | | SIZE | DWG NO |
| APPROVED | | CAGE CODE | DC530A |
| ENGINEER Fran Hoffart | 4/30/02 | SCALE | FILENAME: |
| DESIGNER | | REV | OF |
| Tuesday, July 09, 2002 | | A | 1 |