

FEATURES

mSure sensor monitoring

- Noninvasive, real-time, direct, precision measurement of the input signal path
- Detects changes in meter accuracy and amount of drift over the life of the meter
- Identifies sensor malfunction
- Enables advanced tamper detection methods
- Companion MCU firmware to facilitate diagnostic data reporting
- Supported for shunts on the phase line and CTs on the neutral line

mSure self-calibration

- Self-calibration based on a direct measurement of the full signal path
- Calibration procedure not requiring a reference meter

3 high performance ADCs

- 88 dB SNR
- High gain current channel: ± 26.04 mV peak, 18.4 mV rms input at highest gain setting

Advanced metrology feature set

- Watt, VAR, VA, Wh, VARh, and VAh
- Supports active energy standards: IEC 62053-21; IEC 62053-22; EN50470-3; OIML R46; and ANSI C12.20
- Supports reactive energy standards: IEC 62053-23 and IEC 62053-24

- Current and voltage rms measurement

Operating temperature, industrial range: -40°C to $+85^{\circ}\text{C}$

Integrated temperature sensor with a 12-bit successive approximation register (SAR) ADC

GENERAL DESCRIPTION

The ADE9153B¹ is a highly accurate, single phase, energy metering IC with sensor monitoring and self-calibration. Sensor monitoring with mSure[®] technology allows meter health monitoring and advanced tamper detection. The monitoring feature allows the user to check the overall accuracy of the sensor and signal path to identify accuracy drifts that occur over time on the current and voltage channels, independently. Similarly, mSure offers advanced tamper detection with the capability to detect unusual changes to the sensors. mSure runs in parallel to the metering measurements, allowing uninterrupted and unaffected metrology in the ADE9153B. Self-calibration with mSure enables a meter to automatically calibrate the current and voltage channels without accurate reference meters or accurate sources when a shunt resistor is used as the current sensor. The self-calibration feature supports Class 1 and Class 2 meters.

The ADE9153B includes three high performance analog-to-digital converters (ADCs), providing an 88 dB signal-to-noise ratio (SNR). The ADE9153B offers accurate measurement of line voltage and current, and calculates active, fundamental reactive, and apparent energy, as well as rms. A wide range of power quality information is included, such as dip and swell detection. Current Channel A is ideal for shunts and has a flexible gain stage providing full-scale input ranges from 62.5 mV peak down to 26.04 mV peak. Current Channel B has gain stages of 1 \times , 2 \times , and 4 \times for use with current transformers (CTs). A high speed, 10 MHz, serial peripheral interface (SPI) port allows access to the ADE9153B registers.

Note that throughout this data sheet, multifunction pins, such as ZX/DREADY/CF2, are referred to either by the entire pin name or by a single function of the pin, such as CF2, when only that function is relevant.

TYPICAL APPLICATIONS CIRCUIT

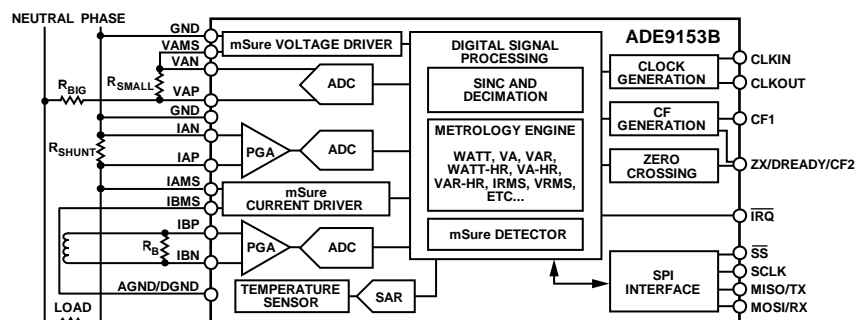

Figure 1.

¹ Protected by U.S. Patents 8,350,558; 8,010,304; WO2013038176 A3; 0113507 A1; 0253102 A1; 0354266 A1; and 0154029 A1.

For more information about the ADE9153B, contact your local Analog Devices Sales Team or visit www.analog.com/mSure.

Rev. SpA
Document Feedback
 Information furnished by Analog Devices is believed to be accurate and reliable. However, no responsibility is assumed by Analog Devices for its use, nor for any infringements of patents or other rights of third parties that may result from its use. Specifications subject to change without notice. No license is granted by implication or otherwise under any patent or patent rights of Analog Devices. Trademarks and registered trademarks are the property of their respective owners.

One Technology Way, P.O. Box 9106, Norwood, MA 02062-9106, U.S.A.
 Tel: 781.329.4700 ©2017–2019 Analog Devices, Inc. All rights reserved.
Technical Support www.analog.com

NOTES