



ACCESSORIES

ST RELAYS

TERMINAL SOCKETS



Terminal socket for PC board



Terminal socket for soldering

RoHS compliant

TYPES

Product name	Part No.
Terminal socket for PC board	ST-PS
Terminal socket for soldering	ST-SS

FEATURES

1. Possible to fit or remove the chassis with one touch ($t = 0.6 \text{ mm to } 2.2 \text{ mm}$.024 inch to .087 inch)
2. Easy design of PC board pattern (2.54 mm x 4 pitch DIL terminal array)
3. High breakdown voltage.

SPECIFICATIONS

Item	Specifications
Breakdown voltage (Initial)	Between contact and coil: 4,000 Vrms for 1 min. (Detection current: 10 mA) Between contact and terminal: 2,000 Vrms for 1 min.
Insulation resistance (Initial)	Min. 1,000 MΩ between terminals (500V DC)
Heat resistance	150°C 302°F for 1 hr
Max. continuous current	10 A
Relay insertion life	15 times

DIMENSIONS (mm inch)

Terminal socket for PC board

CAD Data

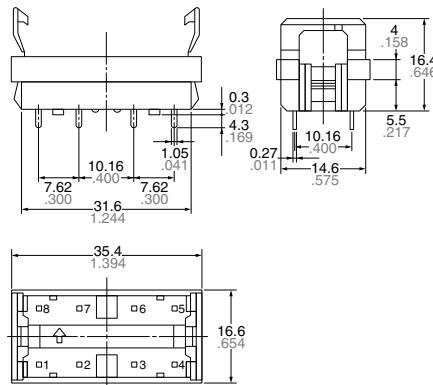

Terminal socket for soldering

CAD Data

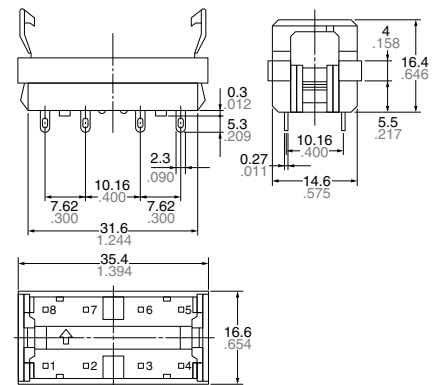

The CAD data of the products with a **CAD Data** mark can be downloaded from: <http://industrial.panasonic.com/ac/e/>

PRECAUTIONS FOR USE (SOCKET)

1. PC board mounting method

PC board pattern

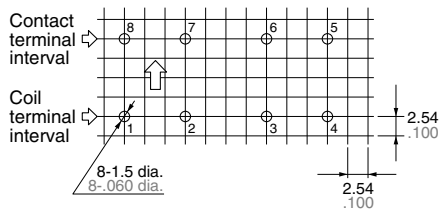

The terminal configuration is symmetrical on the left and right, so an arrow mark \uparrow is stamped on the socket to prevent mis-insertion. We recommend printing the same arrow mark \uparrow on the component mounting side (side opposite from pattern) of the PC board. In this case, the terminal configuration becomes the terminal nos. noted near the drilling holes.

2. Chassis cutout

Chassis cutting dimensions

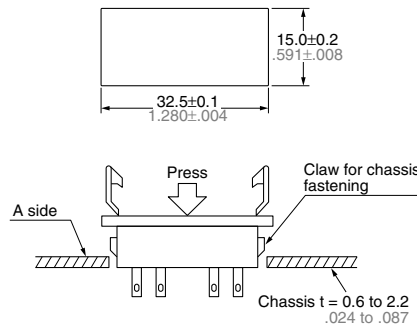

If the chassis hole is punched with a press, set so the release R on the front side (A side). The range for chassis thickness is 0.6 to 2.2 mm .024 to .087 inch.

3. Relay mounting and removal

(1) Align the directions of the relay and socket.

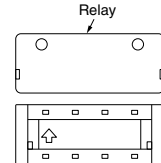

(2) Insert the relay all the way in, so it is securely in place.

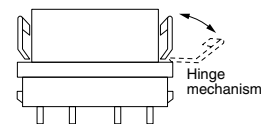

(3) Press the part indicated by A in the B direction, and fasten by placing the hook on the relay.

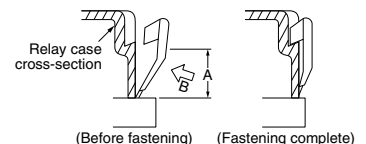

(4) When removing the relay, completely release the hooks on both sides and pull the relay out.

Please contact

Panasonic Corporation

Electromechanical Control Business Division

■ 1006, Oaza Kadoma, Kadoma-shi, Osaka 571-8506, Japan
industrial.panasonic.com/ac/e/

Panasonic[®]

©Panasonic Corporation 2017

ASCTB211E 201701-T

Specifications are subject to change without notice.