

## DESCRIPTION

Demonstration circuit DC872A features the LTC4213 NoRsense Electronic Circuit Breaker, which provides over-current protection without a sense resistor. The

Board allows evaluation of the LTC4213 over its full operating voltage range, at all three over-current protection levels and with ON and RESET functionality.

**Design files for this circuit board are available. Call the LTC factory.**

LT, LTC and LT are registered trademarks of Linear Technology Corporation. ThinSOT and PowerPath are trademarks of Linear Technology Corporation.

## PERFORMANCE SUMMARY

Specifications are at  $T_A = 25^\circ\text{C}$

SYMBOL	PARAMETER	CONDITIONS	MIN	TYP	MAX	UNITS
$V_{CC}$	Supply Voltage Range		2.6		6.0	V
$V_{SENSEP}$	SENSEP Voltage Range	$V_{SENSEP} \leq V_{CC}$	0		6.0	V
$V_{CC}(URLR)$	$V_{CC}$ Undervoltage Lockout Release	$V_{CC}$ Rising	1.8	2.1	2.23	V
$V_{CB}$	Circuit Breaker Trip Voltage $V_{CB} = V_{SENSEP} - V_{SENSEN}$ at slow comparator Trips	$V_{SENSEP} = V_{CC}, I_{OSEL} = 0V$ $V_{SENSEP} = V_{CC}, I_{OSEL} = \text{Floated}$ $V_{SENSEP} = V_{CC}, I_{OSEL} = V_{CC}$	22.5 45 90	25 50 100	23 55 110	mV
$V_{CB}(FAST)$	Circuit Breaker Trip Voltage $V_{CB}(FAST) = V_{SENSEP} - V_{SENSEN}$ at fast comparator Trips	$V_{SENSEP} = V_{CC}, I_{OSEL} = 0V$ $V_{SENSEP} = V_{CC}, I_{OSEL} = \text{Floated}$ $V_{SENSEP} = V_{CC}, I_{OSEL} = V_{CC}$		100 175 325		mV mV mV
$I_{GATE(UP)}$	Gate Pin Pull Up Current	$V_{GATEN} = 0V,$	-50	-100	-150	$\mu\text{A}$
$I_{GATE(DN)}$	Gate Pin Pull Down Current	$V_{ON} = 1V, \Delta = V_{SENSEP} - V_{SENSEN} = 200\text{ mV},$ $V_{GATE} = 8V$	10	40	80	mA
$V_{ON(TH)}$	ON Pin High Threshold	ON Rising, Gate Pulls Down	0.76	0.8	0.84	V
$V_{ON(RST)}$	ON Pin Reset Threshold	ON Falling, Fault Reset, Gate Pulled Down	0.36	0.4	0.44	V

## OPERATING PRINCIPLES

The LTC4213 is an Electronic Circuit Breaker that has a 0V to 6.0V operating range and a 10V absolute maximum operating voltage for the  $V_{CC}$  pin. In low voltage applications where the rail voltage is lower than 2.6V, the  $V_{CC}$  pin must have a separate supply.

The circuit Breaker function is based on sensing the voltage across the drain and source of an external N-channel MOSFET. The LTC4213 provides dual level over-current protection. The slow comparator has 15 $\mu\text{s}$  response time while the fast comparator trips in 1 $\mu\text{s}$ .

One of three Circuit Breaker thresholds, 25mV, 50mV, or 100mV is selected by connecting ISEL pin to GND, leaving it floating, or connecting to  $V_{CC}$ , respectively. The corresponding fast comparator thresholds are 100mV, 175mV, and 325mV.

When the ON pin signal increases above 0.8V, the device starts up and the GATE pulls up with a 100 $\mu\text{A}$  current source. When the ON pin signal drops below 0.76V, the GATE pulls down. To reset a circuit breaker fault, the ON pin must go below 0.4V.

REVISION HISTORY				
ECO	REV	DESCRIPTION	DATE	APPROVED
	2	PROD	06/22/05	

This circuit is proprietary to Linear Technology and supplied for use with Linear Technology parts.  
**Customer Notice:** Linear Technology has made a best effort to design a circuit that meets customer-supplied specifications; however, it remains the customers responsibility to verify proper and reliable operation in the actual application. Component substitution and printed circuit board layout may significantly affect circuit performance or reliability. Contact Linear Applications Engineering for assistance.

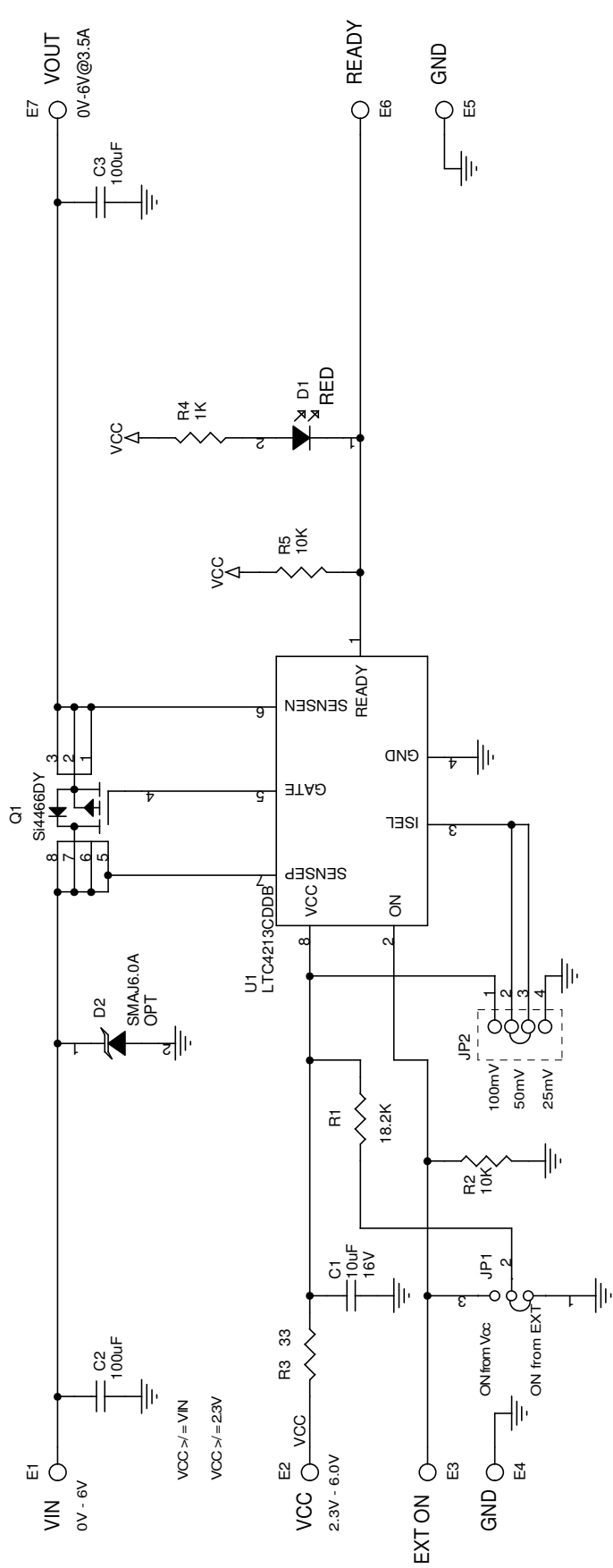

1630 McCarthy Blvd.  
 Milpitas, CA 95035  
 Phone: (408)432-1900  
 Fax: (408)434-0507

TITLE SCH, LTC4213CDDDB, FAST CIRCUIT BREAKER

CONTRACT NO.		
APPROVALS	DATE	12/02/04
DRAWN MEI		
CHECKED		
APPROVED		
ENGINEER		
DESIGNER		
UNLESS OTHERWISE SPECIFIED DIMENSIONS ARE IN INCHES TOLERANCE ON ANGLE . . . 2 PLACES . . . 3 PLACES . . . INTERPRET DIM AND TOL PER ASME Y14.5M - 1994		
THIRD ANGLE PROJECTION		
DO NOT SCALE DRAWING		
Wednesday, April 26, 2006		
SCALE: NONE	FILENAME: 872A-2.DSN	SHEET 1 OF 1
SIZE A	CAGE CODE	DWG NO DC872A
REV 2		

## QUICK START PROCEDURE

1. Adjust electronic or passive load to 1A-1.2A current and connect it between the Vout and GND terminals.
2. Connect a signal source (power supply, pulse generator, etc.) between the ON and GND board terminals and disable its output.
3. Connect Power Supply output to VIN and GND. If the power supply voltage is between 2.6V and 6V, connect the Vcc terminal to Vin. If the power supply voltage is lower than 2.6V use an additional voltage source for Vcc.
4. Figure 1 illustrates DC872A connection with external equipment.
5. Install current level selection jumper in the 25mV position.
6. Activate ON signal source and observe output voltage transient.
7. Increase the load to 2.0-2.5A and observe circuit breaker performance.
8. Repeat 5 and 6 with current level selection jumper the 50mV and 100mV positions and corresponding loads of 3.8-4.2A and 7.0-7.5A.

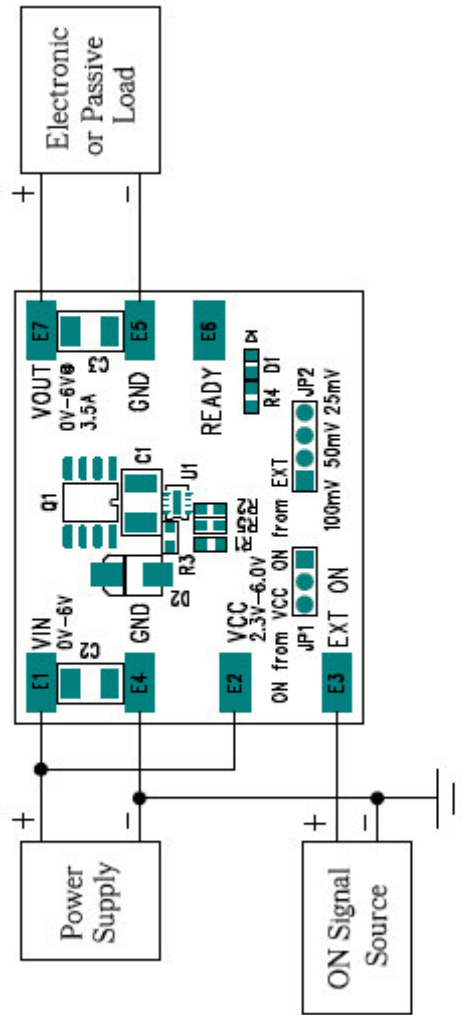

Fig. 1 DC872A Connection with External Equipment