

FEATURES

Low Insertion Loss and On Resistance: 4 Ω Typical
On-Resistance Flatness <2 Ω
Bandwidth >200 MHz
Single 3 V/5 V Supply Operation
Rail-to-Rail Operation
Very Low Distortion: <1%
Low Quiescent Supply Current (100 nA Typical)
Fast Switching Times

t_{ON} 10 ns

t_{OFF} 4 ns

TTL/CMOS Compatible

**For Functionally Equivalent Devices in 16-Lead QSOP/
SOIC Packages, See ADG774**

APPLICATIONS

100VG-AnyLAN

Token Ring 4 Mbps/16 Mbps

ATM25/155

NIC Adapter and Hubs

Audio and Video Switching

Relay Replacement

FUNCTIONAL BLOCK DIAGRAM

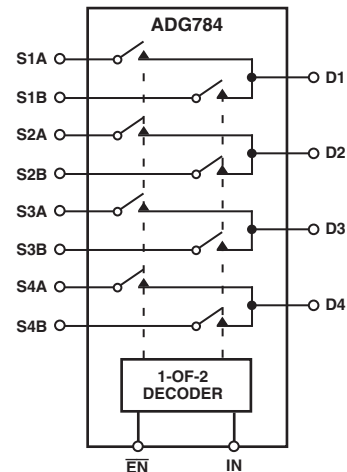

GENERAL DESCRIPTION

The ADG784 is a monolithic CMOS device comprising four 2:1 multiplexer/demultiplexers with high impedance outputs. The CMOS process provides low power dissipation yet gives high switching speed and low on resistance. The on-resistance variation is typically less than 0.5 Ω with an input signal ranging from 0 V to 5 V.

The bandwidth of the ADG784 is greater than 200 MHz and this, coupled with low distortion (typically 0.5%), makes the part suitable for switching fast ethernet signals.

The on-resistance profile is very flat over the full analog input range ensuring excellent linearity and low distortion when switching audio signals. Fast switching speed, coupled with high signal bandwidth, also makes the parts suitable for video signal switching. CMOS construction ensures ultralow power dissipation making the parts ideally suited for portable and battery powered instruments.

The ADG784 operates from a single 3.3 V/5 V supply and is TTL logic compatible. The control logic for each switch is shown in the Truth Table.

These switches conduct equally well in both directions when ON, and have an input signal range that extends to the supplies. In the OFF condition, signal levels up to the supplies are blocked. The ADG784 switches exhibit break-before-make switching action.

PRODUCT HIGHLIGHTS

1. Also Available as ADG774 in 16-Lead QSOP and SOIC.
2. Wide Bandwidth Data Rates >200 MHz.
3. Ultralow Power Dissipation.
4. Extended Signal Range.

The ADG784 is fabricated on a CMOS process giving an increased signal range that fully extends to the supply rails.

5. Low Leakage over Temperature.
6. Break-Before-Make Switching.
This prevents channel shorting when the switches are configured as a multiplexer.
7. Crosstalk is typically -70 dB @ 30 MHz.
8. Off isolation is typically -60 dB @ 10 MHz.
9. Available in Chip Scale Package (CSP).

REV. A

Information furnished by Analog Devices is believed to be accurate and reliable. However, no responsibility is assumed by Analog Devices for its use, nor for any infringements of patents or other rights of third parties that may result from its use. No license is granted by implication or otherwise under any patent or patent rights of Analog Devices.

One Technology Way, P.O. Box 9106, Norwood, MA 02062-9106, U.S.A.
Tel: 781/329-4700 www.analog.com
Fax: 781/461-3113 © Analog Devices, Inc., 2013

ADG784—SPECIFICATIONS

SINGLE SUPPLY ($V_{DD} = 5\text{ V} \pm 10\%$, $GND = 0\text{ V}$. All specifications T_{MIN} to T_{MAX} unless otherwise noted.)

Parameter	B Version		Unit	Test Conditions/Comments
	25°C	T_{MIN} to T_{MAX}		
ANALOG SWITCH				
Analog Signal Range		0 V to V_{DD}	V	
On Resistance (R_{ON})	2.2	5	Ω typ Ω max	$V_D = 0\text{ V to }V_{DD}$, $I_S = -10\text{ mA}$
On Resistance Match Between Channels (ΔR_{ON})	0.15	0.5	Ω typ Ω max	$V_D = 0\text{ V to }V_{DD}$, $I_S = -10\text{ mA}$
On Resistance Flatness ($R_{FLAT(ON)}$)	0.5	1	Ω typ Ω max	$V_D = 0\text{ V to }V_{DD}$; $I_S = -10\text{ mA}$
LEAKAGE CURRENTS				
Source OFF Leakage I_S (OFF)	± 0.01		nA typ nA max	$V_D = 4.5\text{ V}$, $V_S = 1\text{ V}$; $V_D = 1\text{ V}$, $V_S = 4.5\text{ V}$; Test Circuit 2
Drain OFF Leakage I_D (OFF)	± 0.01	± 1	nA typ nA max	$V_D = 4.5\text{ V}$, $V_S = 1\text{ V}$; $V_D = 1\text{ V}$, $V_S = 4.5\text{ V}$; Test Circuit 2
Channel ON Leakage I_D , I_S (ON)	± 0.01	± 1	nA typ nA max	$V_D = V_S = 4.5\text{ V}$; $V_D = V_S = 1\text{ V}$; Test Circuit 3
DIGITAL INPUTS				
Input High Voltage, V_{INH}		2.4	V min	
Input Low Voltage, V_{INL}		0.8	V max	
Input Current I_{INL} or I_{INH}	0.001	± 0.5	μA typ μA max	$V_{IN} = V_{INL}$ or V_{INH}
DYNAMIC CHARACTERISTICS²				
t_{ON}		10 20	ns typ ns max	$R_L = 100\ \Omega$, $C_L = 35\text{ pF}$, $V_S = 3\text{ V}$; Test Circuit 4
t_{OFF}		4 8	ns typ ns max	$R_L = 100\ \Omega$, $C_L = 35\text{ pF}$, $V_S = 3\text{ V}$; Test Circuit 4
Break-Before-Make Time Delay, t_D		5 1	ns typ ns min	$R_L = 100\ \Omega$, $C_L = 35\text{ pF}$, $V_{S1} = V_{S2} = 5\text{ V}$; Test Circuit 5
Off Isolation		-65	dB typ	$R_L = 100\ \Omega$, $f = 10\text{ MHz}$; Test Circuit 7
Channel-to-Channel Crosstalk		-75	dB typ	$R_L = 100\ \Omega$, $f = 10\text{ MHz}$; Test Circuit 8
Bandwidth -3 dB		240	MHz typ	$R_L = 100\ \Omega$; Test Circuit 6
Distortion		0.5	% typ	$R_L = 100\ \Omega$
Charge Injection		10	pC typ	$C_L = 1\text{ nF}$; Test Circuit 9
C_S (OFF)		10	pF typ	$f = 1\text{ kHz}$
C_D (OFF)		20	pF typ	$f = 1\text{ kHz}$
C_D , C_S (ON)		30	pF typ	$f = 1\text{ MHz}$
POWER REQUIREMENTS				
I_{DD}	0.001	1	μA max μA typ	$V_{DD} = 5.5\text{ V}$ Digital Inputs = 0 V or V_{DD}
I_{IN}		1	μA typ	$V_{IN} = 5\text{ V}$
I_O		100	mA max	$V_S/V_D = 0\text{ V}$

NOTES

¹Temperature ranges are as follows: B Version, -40°C to $+85^\circ\text{C}$.

²Guaranteed by design, not subject to production test.

Specifications subject to change without notice.

SINGLE SUPPLY ($V_{DD} = 3\text{ V} \pm 10\%$, $GND = 0\text{ V}$. All specifications T_{MIN} to T_{MAX} unless otherwise noted.)

Parameter	B Version T_{MIN} to T_{MAX}		Unit	Test Conditions/Comments
	25°C			
ANALOG SWITCH				
Analog Signal Range		0 V to V_{DD}	V	
On Resistance (R_{ON})	4	10	Ω typ Ω max	$V_D = 0\text{ V}$ to V_{DD} , $I_S = -10\text{ mA}$
On Resistance Match Between Channels (ΔR_{ON})	0.15	0.5	Ω typ Ω max	$V_D = 0\text{ V}$ to V_{DD} , $I_S = -10\text{ mA}$
On Resistance Flatness ($R_{FLAT(ON)}$)	2	4	Ω typ Ω max	$V_D = 0\text{ V}$ to V_{DD} , $I_S = -10\text{ mA}$
LEAKAGE CURRENTS				
Source OFF Leakage I_S (OFF)	± 0.01 ± 0.5	± 1	nA typ nA max	$V_D = 3\text{ V}$, $V_S = 1\text{ V}$; $V_D = 1\text{ V}$, $V_S = 3\text{ V}$; Test Circuit 2
Drain OFF Leakage I_D (OFF)	± 0.01 ± 0.5	± 1	nA typ nA max	$V_D = 3\text{ V}$, $V_S = 1\text{ V}$; $V_D = 1\text{ V}$, $V_S = 3\text{ V}$; Test Circuit 2
Channel ON Leakage I_D , I_S (ON)	± 0.01 ± 0.5	± 1	nA typ nA max	$V_D = V_S = 3\text{ V}$; $V_D = V_S = 1\text{ V}$; Test Circuit 3
DIGITAL INPUTS				
Input High Voltage, V_{INH}		2.0	V min	
Input Low Voltage, V_{INL}		0.4	V max	
Input Current I_{INL} or I_{INH}	0.001	± 0.5	μA typ μA max	$V_{IN} = V_{INL}$ or V_{INH}
DYNAMIC CHARACTERISTICS²				
t_{ON}		12 25	ns typ ns max	$R_L = 100\ \Omega$, $C_L = 35\text{ pF}$, $V_S = 1.5\text{ V}$; Test Circuit 4
t_{OFF}		5 10	ns typ ns max	$R_L = 100\ \Omega$, $C_L = 35\text{ pF}$, $V_S = 1.5\text{ V}$; Test Circuit 4
Break-Before-Make Time Delay, t_D		5 1	ns typ ns min	$R_L = 100\ \Omega$, $C_L = 35\text{ pF}$, $V_{S1} = V_{S2} = 3\text{ V}$; Test Circuit 5
Off Isolation		-65	dB typ	$R_L = 50\ \Omega$, $f = 10\text{ MHz}$; Test Circuit 7
Channel-to-Channel Crosstalk		-75	dB typ	$R_L = 50\ \Omega$, $f = 10\text{ MHz}$; Test Circuit 8
Bandwidth -3 dB		240	MHz typ	$R_L = 50\ \Omega$; Test Circuit 6
Distortion		2	% typ	$R_L = 50\ \Omega$
Charge Injection		3	pC typ	$C_L = 1\text{ nF}$; Test Circuit 9
C_S (OFF)		10	pF typ	$f = 1\text{ kHz}$
C_D (OFF)		20	pF typ	$f = 1\text{ kHz}$
C_D , C_S (ON)		30	pF typ	$f = 1\text{ MHz}$
POWER REQUIREMENTS				
I_{DD}	0.001	1	μA max μA typ	$V_{DD} = 3.3\text{ V}$ Digital Inputs = 0 V or V_{DD}
I_{IN}		1	μA typ	$V_{IN} = 3\text{ V}$
I_O		100	mA max	$V_S/V_D = 0\text{ V}$

NOTES

¹Temperature ranges are as follows: B Version, -40°C to $+85^\circ\text{C}$.²Guaranteed by design, not subject to production test.

Specifications subject to change without notice.

Table I. Truth Table

$\overline{\text{EN}}$	IN	D1	D2	D3	D4	Function
1	X	Hi-Z	Hi-Z	Hi-Z	Hi-Z	DISABLE
0	0	S1A	S2A	S3A	S4A	IN = 0
0	1	S1B	S2B	S3B	S4B	IN = 1

ADG784

ABSOLUTE MAXIMUM RATINGS¹

(T_A = 25°C unless otherwise noted.)

V _{DD} to GND	-0.3 V to +6 V
Analog, Digital Inputs ²	-0.3 V to V _{DD} + 0.3 V or 30 mA, Whichever Occurs First
Continuous Current, S or D	100 mA
Peak Current, S or D	300 mA (Pulsed at 1 ms, 10% Duty Cycle max)
Operating Temperature Range		
Industrial (B Version)	-40°C to +85°C
Storage Temperature Range	-65°C to +150°C
Junction Temperature	150°C
Chip Scale Package		
θ _{JA} Thermal Impedance	32°C/W
Lead Temperature, Soldering		
Vapor Phase (60 sec)	215°C
Infrared (15 sec)	220°C
ESD	2 kV

NOTES

¹Stresses above those listed under Absolute Maximum Ratings may cause permanent damage to the device. This is a stress rating only; functional operation of the device at these or any other conditions above those listed in the operational sections of this specification is not implied. Exposure to absolute maximum rating conditions for extended periods may affect device reliability. Only one absolute maximum rating may be applied at any one time.

²Overvoltages at IN, S or D will be clamped by internal diodes. Current should be limited to the maximum ratings given.

PIN CONFIGURATION

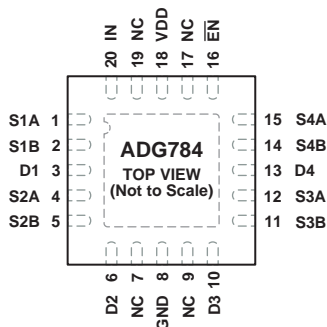

NOTES

1. NC = NO CONNECT.
2. EXPOSED PAD TIED TO SUBSTRATE, GND.

TERMINOLOGY

V _{DD}	Most Positive Power Supply Potential.
GND	Ground (0 V) Reference.
S	Source Terminal. May be an input or output.
D	Drain Terminal. May be an input or output.
IN	Logic Control Input.
$\overline{\text{EN}}$	Logic Control Input.
R _{ON}	Ohmic resistance between D and S.
ΔR _{ON}	On Resistance match between any two channels i.e., R _{ON max} – R _{ON min} .
R _{FLAT(ON)}	Flatness is defined as the difference between the maximum and minimum value of on resistance as measured over the specified analog signal range.
I _S (OFF)	Source Leakage Current with the switch “OFF.”
I _D (OFF)	Drain Leakage Current with the switch “OFF.”
I _D , I _S (ON)	Channel Leakage Current with the switch “ON.”
V _D (Vs)	Analog Voltage on Terminals D, S.
C _S (OFF)	“OFF” Switch Source Capacitance.
C _D (OFF)	“OFF” Switch Drain Capacitance.
C _D , C _S (ON)	“ON” Switch Capacitance.
t _{ON}	Delay between applying the digital control input and the output switching on. See Test Circuit 4.
t _{OFF}	Delay between applying the digital control input and the output switching Off.
t _D	“OFF” time or “ON” time measured between the 90% points of both switches, when switching from one address state to another. See Test Circuit 5.
Crosstalk	A measure of unwanted signal that is coupled through from one channel to another as a result of parasitic capacitance.
Off Isolation	A measure of unwanted signal coupling through an “OFF” switch.
Bandwidth	Frequency response of the switch in the ON state measured at 3 dB down.
Distortion	R _{FLAT(ON)} /R _L

CAUTION

ESD (electrostatic discharge) sensitive device. Electrostatic charges as high as 4000 V readily accumulate on the human body and test equipment and can discharge without detection. Although the ADG784 features proprietary ESD protection circuitry, permanent damage may occur on devices subjected to high-energy electrostatic discharges. Therefore, proper ESD precautions are recommended to avoid performance degradation or loss of functionality.



Typical Performance Characteristics—ADG784

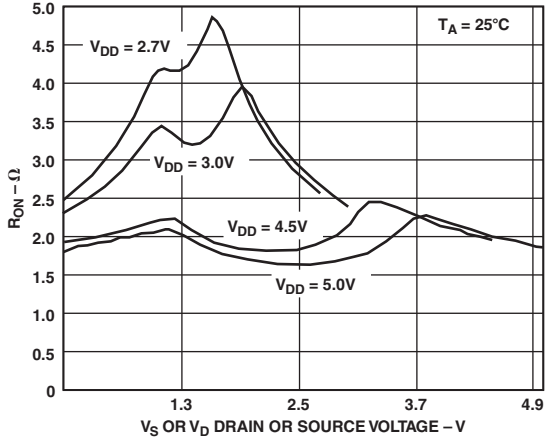

TPC 1. On Resistance as a Function of V_D (V_S) for Various Single Supplies

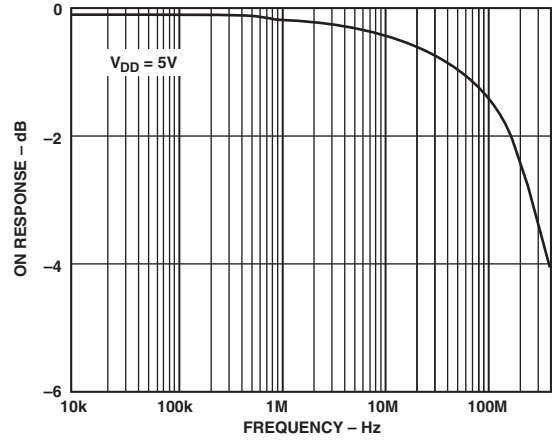

TPC 4. On Response vs. Frequency

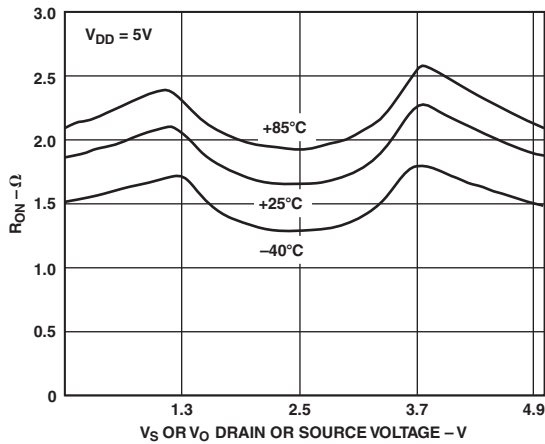

TPC 2. On Resistance as a Function of V_D (V_S) for Different Temperatures with 5 V Single Supplies

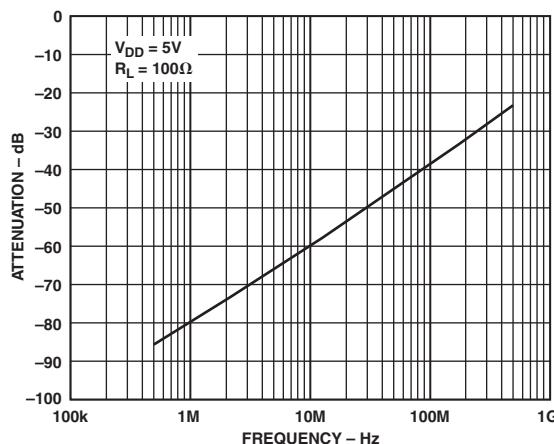

TPC 5. Off Isolation vs. Frequency

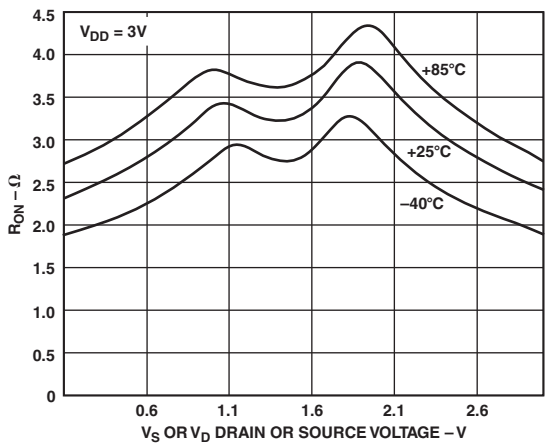

TPC 3. On Resistance as a Function of V_D (V_S) for Different Temperatures with 3 V Single Supplies

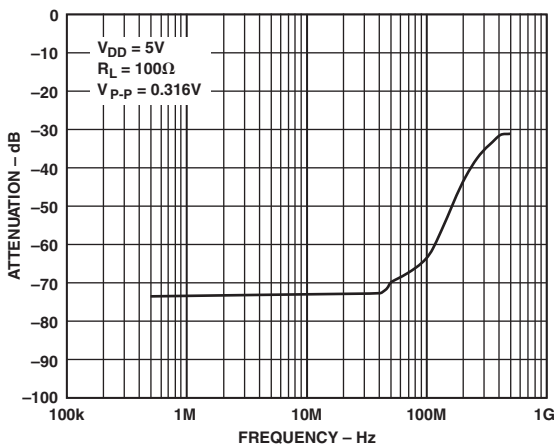

TPC 6. Crosstalk vs. Frequency

ADG784

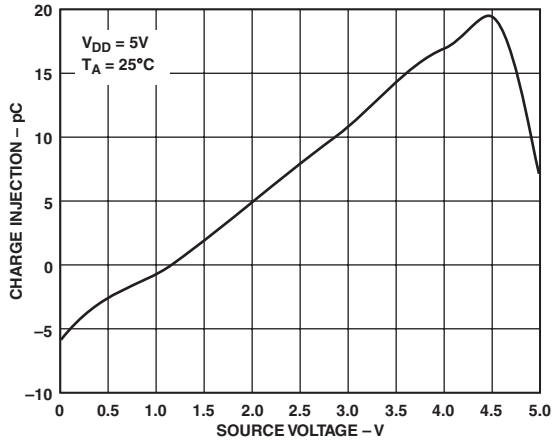

TPC 7. Charge Injection vs. Source Voltage

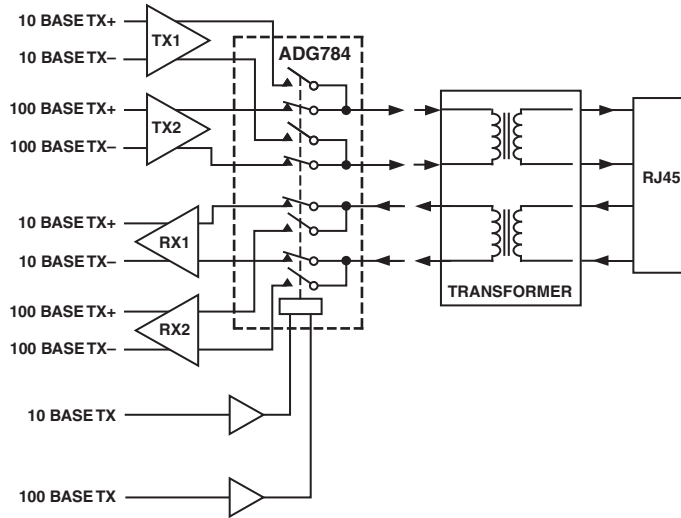

Figure 1. Full Duplex Transceiver

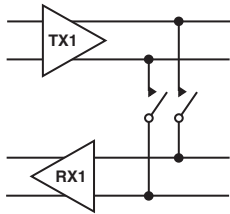

Figure 2. Loop Back

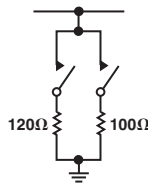

Figure 3. Line Termination

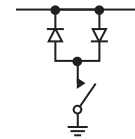
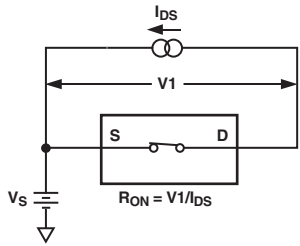
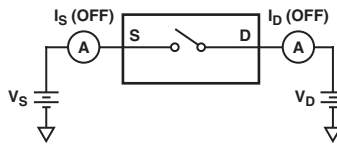

Figure 4. Line Clamp

Test Circuits



Test Circuit 1. On Resistance



Test Circuit 2. Off Leakage

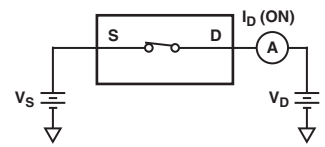

Test Circuit 3. On Leakage

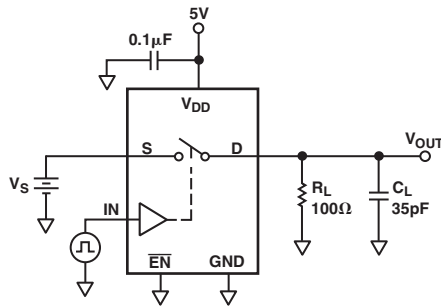

Test Circuit 4. Switching Times

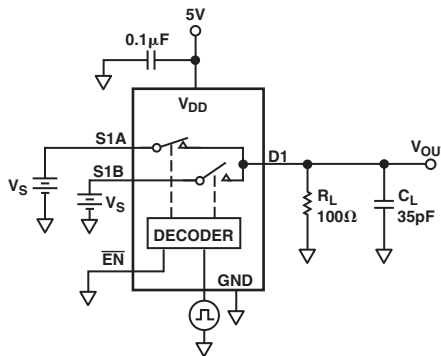

Test Circuit 5. Break-Before-Make Time Delay

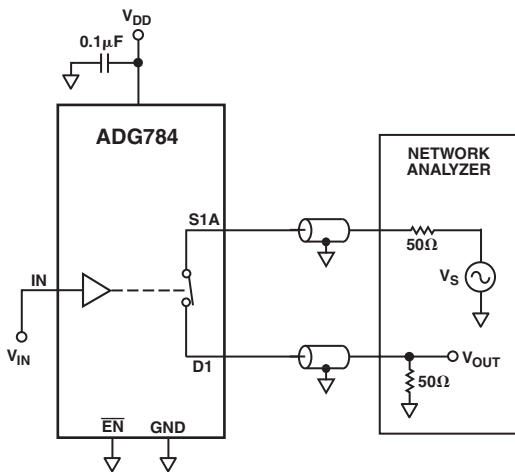

Test Circuit 6. Bandwidth

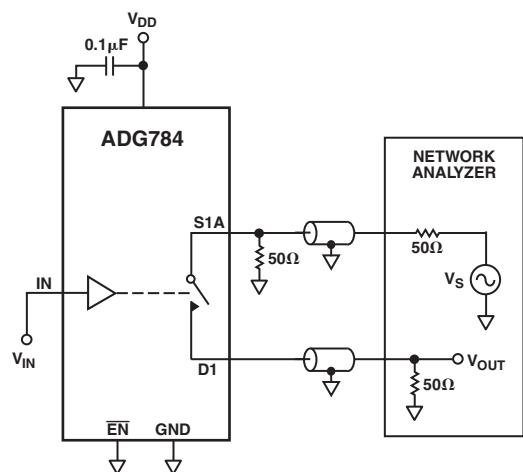

Test Circuit 7. Off Isolation

ADG784

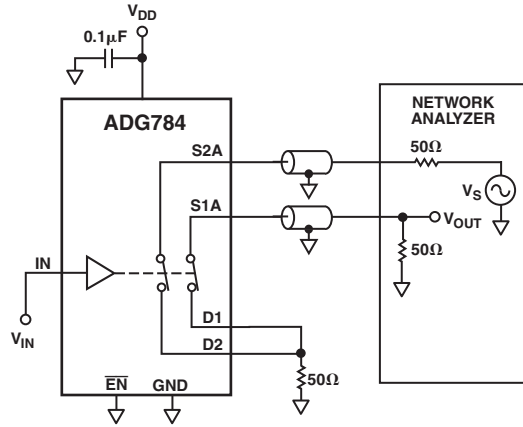

Test Circuit 8. Channel-to-Channel Crosstalk

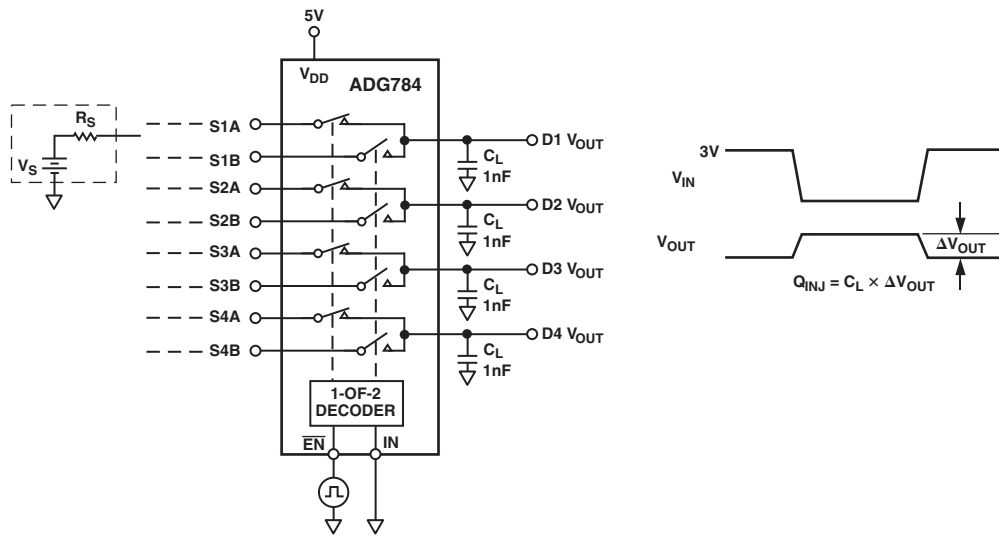

Test Circuit 9. Charge Injection

OUTLINE DIMENSIONS

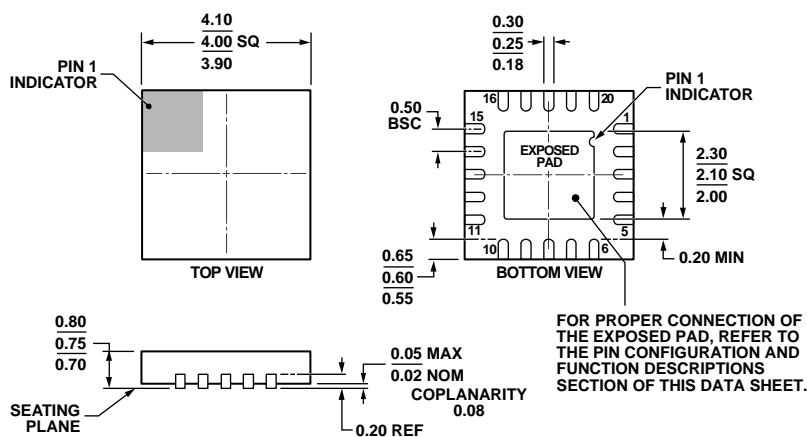

COMPLIANT TO JEDEC STANDARDS MO-220-WGGD-1.

Figure 37. 20-Lead Lead Frame Chip Scale Package [LFCSP_WQ]
 4 mm × 4 mm Body, Very Very Thin Quad
 (CP-20-6)
 Dimensions shown in millimeters

08-16-2010-B

ORDERING GUIDE

Model ¹	Temperature Range	Package Description	Package Option
ADG784BCPZ	-40°C to +85°C	20-Lead LFCSP_WQ	CP-20-6
ADG784BCPZ-REEL	-40°C to +85°C	20-Lead LFCSP_WQ	CP-20-6
ADG784BCPZ-REEL7	-40°C to +85°C	20-Lead LFCSP_WQ	CP-20-6

¹ Z = RoHS Compliant Part.

REVISION HISTORY

2/13—Rev. 0 to Rev. A

Changes to Pin Configuration.....	4
Updated Outline Dimensions.....	9
Changes to Ordering Guide.....	9

4/01—Revision 0: Initial Version