

LTC7003 Fast 60V Protected High Side NMOS Static Switch Driver

DESCRIPTION

Demonstration circuit 2749A is a 60V protected, high side switch featuring the [LTC[®]7003](#). The demo board is designed to switch a 14.5A output load from input voltages from 6V to 60V. The wide input range and low shut-down current (1 μ A typical) make it suitable for automotive, industrial, medical instrument and telecom applications. This board offers a low 45ns (typical) propagation delay, fast switching times (<10ns) and 100% duty cycle operation.

The LTC7003 is a fast protected high side N-channel MOSFET driver. An internal charge pump fully enhances an external N-channel MOSFET switch, allowing it to remain on indefinitely. Its powerful gate driver can drive large gate capacitance MOSFETs with very short transition times, ideal for both high frequency switching and static switch applications. The LTC7003 operates over a 3.5V to 60V input supply range. When an external current sense resistor and internal comparator sense that the switch current has exceeded a preset level, a fault flag is asserted and the switch is turned off after a period of time set by an external timing capacitor. After a cooldown period, the LTC7003 can be configured to automatically retry or remain off until the input is recycled.

The demo board includes input capacitors and output diode to accommodate input and output supply inductance when switching loads. The switch can be controlled directly with external signal or using the on-board on/off switch. A single-shot pulse generator is included for evaluating switching times while limiting output power. Optional auxiliary V_{CC} input accommodates gate power associated with high frequency switching. Positions for RC delay network to control inrush current are also included.

The LTC7003 data sheet gives a complete description of the part, operation and application information. The data sheet must be read in conjunction with this demo manual for demo circuit 2749A. Proper board layout is essential for maximum thermal and electrical performance. See the data sheet sections for details. The LTC7003 is available in 16-lead MSOP package and three operating junction temperature grades extended and industrial from -40°C to 125°C , high temp automotive from -40°C to 150°C and a military grade from -55°C to 150°C .

Design files for this circuit board are available at <http://www.linear.com/demo/DC2749A>

All registered trademarks and trademarks are the property of their respective owners.

PERFORMANCE SUMMARY Specifications are at $T_A = 25^{\circ}\text{C}$

SYMBOL	PARAMETER	CONDITIONS	MIN	TYP	MAX	UNITS
V_{IN}	Input Voltage				60	V
I_{OUT}	Output Current				14.5	A
	Insertion Drop	$V_{IN} - V_{OUT}$, 14.5A Load, Input to Output Terminals		81		mV
V_{IN}	Start-Up Voltage	$V_{INP} = 4\text{V}$ 100k Ω Load		7.0 6.0		V V
V_{CCUV}	V_{CC} Undervoltage Lockout	V_{CC} Rising V_{CC} Falling Hysteresis		5.1 4.6 0.5		V V V
	Overcurrent to V_{OUT} Low	Turn-On into a 25A Resistive Load		19		μs
	Input to Output Propagation Delay	$V_{IN} = 60\text{V}$, 50 Ω Load, INP = 2.2V to $V_{OUT} = 6\text{V}$		45		ns
	Output Rise Time	$V_{IN} = 60\text{V}$, 50 Ω Load, 10% to 90%		9		ns

QUICK START PROCEDURE

Refer to Figure 1 for proper measurement equipment setup and follow the procedure below:

NOTE: When measuring the output voltage during switching transitions, care must be taken to avoid a long ground lead on the oscilloscope probe. Measure the output voltage by touching the probe tip and ground ring directly across the output capacitor as shown in Figure 2.

1. Place SW1 to OFF position. Move JP1 from the PULSE (default position) to ON/OFF position (load on continuously when SW1 is ON).
2. With input power supply set to zero volts and power off, connect the input power supply to +VIN and GND.
3. With power off, connect load from +VOUT to GND.
4. Turn on the input power supply and increase the input voltage slowly to 7V minimum. The input range is up to 60V but hot-plugging with long leads may result in input voltages in excess of 60V.

5. Place SW1 to ON position.
6. Check for the proper output voltage using a voltmeter. Output voltage should be close to input voltage.

NOTE: If there is no output, temporarily disconnect the load and cycle SW1 (the ON/OFF switch) or press reset pushbutton SW2. If output is good, the load may be set too high.

7. Once the proper output voltage is established, adjust the load, if desired, to test current limit.
8. Placing SW1 to OFF position, moving JP1 to PULSE position then placing SW1 in ON position will allow pulse operation. Pushing SW2 will turn the high side switch on for 300µs time.
9. Placing SW1 to OFF position, moving JP1 to INPUT position connects INPUT terminal to LTC7003 INP pin. An INPUT pin voltage of 2.2V or more will turn-on the high side switch.

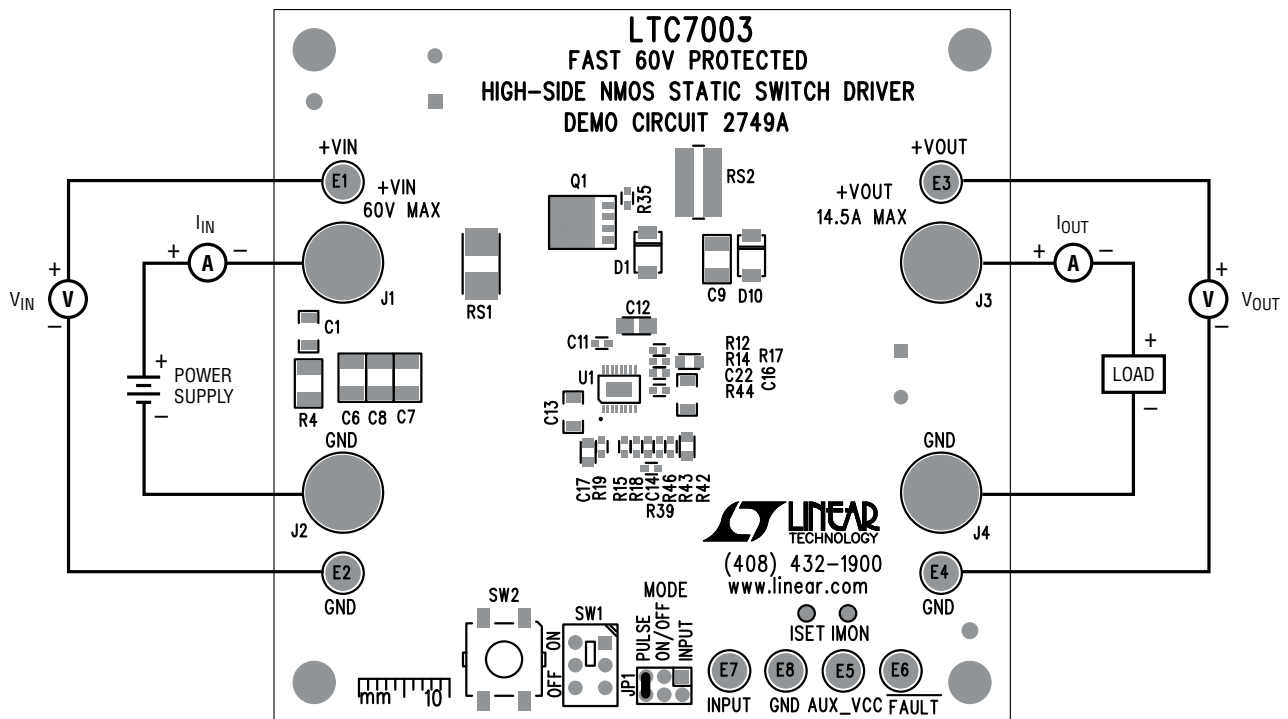

Figure 1. Proper Measurement Equipment Setup

QUICK START PROCEDURE

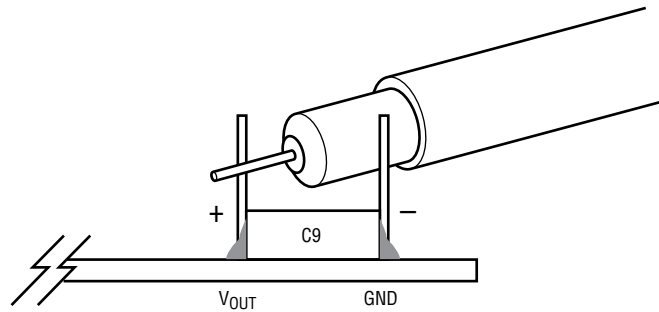

Figure 2. Measuring Output Voltage During Switching across C9. Note that C9 May Not Be Installed

TYPICAL PERFORMANCE CHARACTERISTICS

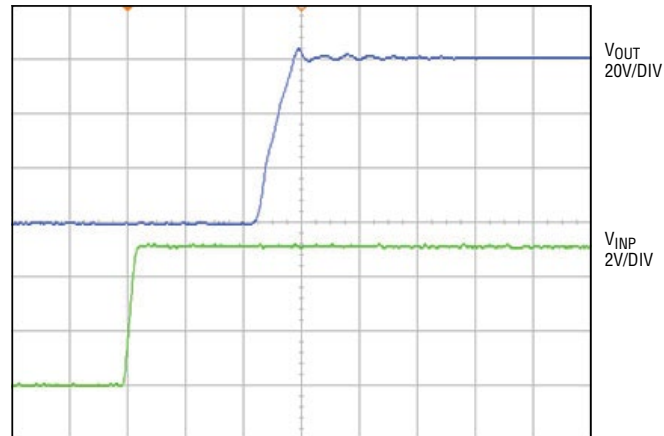

Figure 3. Rise Time into 50Ω Load ($V_{IN} = 60V$, $V_{INP} = 2V/DIV$, $V_{OUT} = 20V/DIV$, 20ns/DIV)

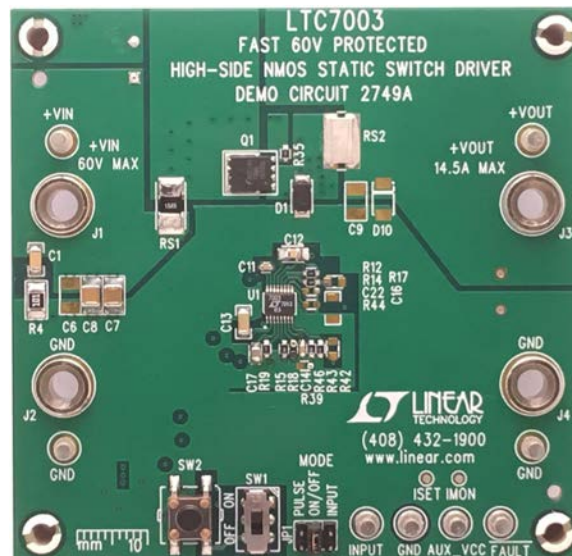

Figure 4. Board Photo

DEMO MANUAL DC2749A

PARTS LIST

ITEM	QTY	REFERENCE	PART DESCRIPTION	MANUFACTURER/PART NUMBER
Required Circuit Components				
1	5	C3, C4, C5, C7, C8	CAP, 4.7 μ F, X7R, 100V, 1210	MURATA, GRM32DC72A475ME01
2	2	C11, C14	CAP, 1000pF, X7R, 25V, 10%, 0603	MURATA, GRM188R71E102KA01D
3	1	C12	CAP, 0.22 μ F, X7R, 25V, 10%, 0805	AVX, 08053C224KAT2A
4	1	C13	CAP, 0.1 μ F, X7R, 100V, 10%, 1206	AVX, 12061C104KAT2A
5	1	C17	CAP, 1 μ F, X7R, 25V, 10%, 0805	AVX, 08053C105KAT2A
6	1	D1	DIODE, SCHOTTKY, 100V, 3A, SOD128	NEXPERIA USA INC, PMEG10030ETPX
7	1	Q1	MOSFET, N-CH, 60V, POWERPAK-SO-8	FAIRCHILD/ON SEMI, FDMS86500L
8	1	RS1	RES, SENSE, 0.0015 Ω , 1W, 1%, 2512	PANASONIC, ERJM1WTF1M5U
9	2	R7	RES, 100 Ω , 1/10W, 1%, 0603	VISHAY CRCW0603100RFKEA
10	2	R15, R46	RES, 100k, 1/10W, 1%, 0603	VISHAY CRCW0603100KFKEA
11	1	R19	RES, 75k, 1/10W, 0603	VISHAY CRCW060375K0FKEA
12	1	R35	RES, 0 Ω , 1/10W, 1%, 0603	VISHAY CRCW06030000Z0EA
13	1	R40	RES, 1MEG, 1/10W, 1%, 0805	VISHAY CRCW08051M00FKEA
14	1	U1	IC, LTC7003EMSE, MSE-16	LINEAR TECH, LTC7003EMSE#PBF
Additional Demo Board Circuit Components				
1	1	C1	CAP, 10nF, X7R, 100V, 10%, 1206	AVX, 12061C103KAZ2A
2	1	C2	CAP, 100 μ F, ELECT, 63V, 20%, TH C-10X12.5	WURTH ELECTRONIC, 860040775006
3	0	C6, C9	CAP, OPTIONAL, 1210	OPTIONAL
4	0	C10	CAP, OPTIONAL, TH C-10X12.5	OPTIONAL
5	0	C16	CAP, OPTIONAL, 1206	OPTIONAL
6	2	C18, C19	CAP, 0.1 μ F, X7R, 25V, 10%, 0603	AVX, 06033C104KAT2A
7	0	C21, C22, C23, C24	CAP, OPTIONAL, 0603	OPTIONAL
8	0	D2, D3, D4, D8, D11, D12	DIODE, OPTIONAL, SOT23	OPTIONAL
9	1	D5	DIODE, MMSZ5V1T1, SOD-123	ON SEMICONDUCTOR, MMSZ5V1T1G
10	1	D6	DIODE, MMBD4148, SOT23	DIODES INC, MMBD4148-7-F
11	0	D7	DIODE, OPTION, PDS4150, POWERDI5	OPTIONAL
12	0	D9	DIODE, OPTION, CMMR1U, SOD-123F	OPTIONAL
13	0	D10	DIODE, OPTIONAL, SOD128	OPTIONAL
14	0	Q2	MOSFET, OPTIONAL, N-CH, 80V, PSOF08A	FAIRCHILD/ON SEMI, FDBL86361_F085
15	0	Q3	MOSFET, OPTIONAL, POWERPAK-SO-8	OPTIONAL
16	1	Q4	TRANS, PNP 40V 0.2A SOT-23	FAIRCHILD/ON SEMI, MMBT3906
17	1	Q5	MOSFET, P-CH, -200V, SOT23	DIODES INC, ZXMP2120FFTA
18	1	RS2	RES, SENSE, 0 Ω , 1/2W, 1%, 1225	TEPRO, RN5326
19	1	R2	RES, 0 Ω , 1/10W, 1%, 0805	VISHAY CRCW08050000Z0EA
20	1	R4	RES, 100 Ω , 1/2W, 5%, 1210	NIC, NRCP25J101TRF
21	9	R6, R12, R14, R22, R25, R43, R45, R47	RES, 0 Ω , 1/10W, 0603	VISHAY CRCW06030000Z0EA
22	0	R9, R17, R41, R42	RES, OPTIONAL, 0805	OPTIONAL
23	0	R13, R18, R33, R34, R36, R39, R44	RES, OPTIONAL, 0603	OPTIONAL
24	3	R21, R37, R38	RES, 100k, 1/10W, 1%, 0603	VISHAY CRCW0603100KFKEA

PARTS LIST

ITEM	QTY	REFERENCE	PART DESCRIPTION	MANUFACTURER/PART NUMBER
25	1	R23	RES, 787Ω, 1/10W, 1%, 0603	VISHAY CRCW0603787RFKEA
26	2	R27, R31	RES, 240k, 1/10W, 1%, 0805	VISHAY CRCW0805240KFKEA
27	1	R28	RES, 976k, 1/10W, 1%, 0603	VISHAY CRCW0603976KFKEA
28	1	R29	RES, 232k, 1/10W, 1%, 0603	VISHAY CRCW0603232KFKEA
29	1	R30	RES, 182k, 1/10W, 1%, 0603	VISHAY CRCW0603182KFKEA
30	1	SW1	SWITCH, SUB MINITURE SLIDE	G&K COMPONENTS, JS202011CQN
31	1	SW2	SWITCH, MICRO MINATURE PUSHBUTTON	TE CONNECTIVITY, FSM4JSMA
32	1	U2	IC, LTC6993CS6-3, TSOT23-6	LINEAR TECH, LTC6993CS6-3#PBF

Hardware: For Demo Board Only

1	8	E1 TO E8	TESTPOINT, TURRET 0.094"	MILL MAX 2501-2-00-80-00-00-07-0
2	1	JP1	CONN., HEADER, 2X3, 2mm	WURTH ELEKTRONIK, 62000621121
3	4	J1, J2, J3, J4	CONN, BANANA JACK	KEYSTONE 575-4
4	1	XJP1	SHUNT, 2MM	WURTH ELEKTRONIK, 60800213421
5	4	MTGS. AT 4 CORNERS	STAND-OFF, NYLON 0.625" TALL	WURTH ELEKTRONIK, 702936000

Misc:

1	1		PCB, DC2749A	DEMO CIRCUIT 2749A
2	2		STENCIL (TOP & BOTTOM)	STENCIL DC2749A

DEMO MANUAL DC2749A

SCHEMATIC DIAGRAM

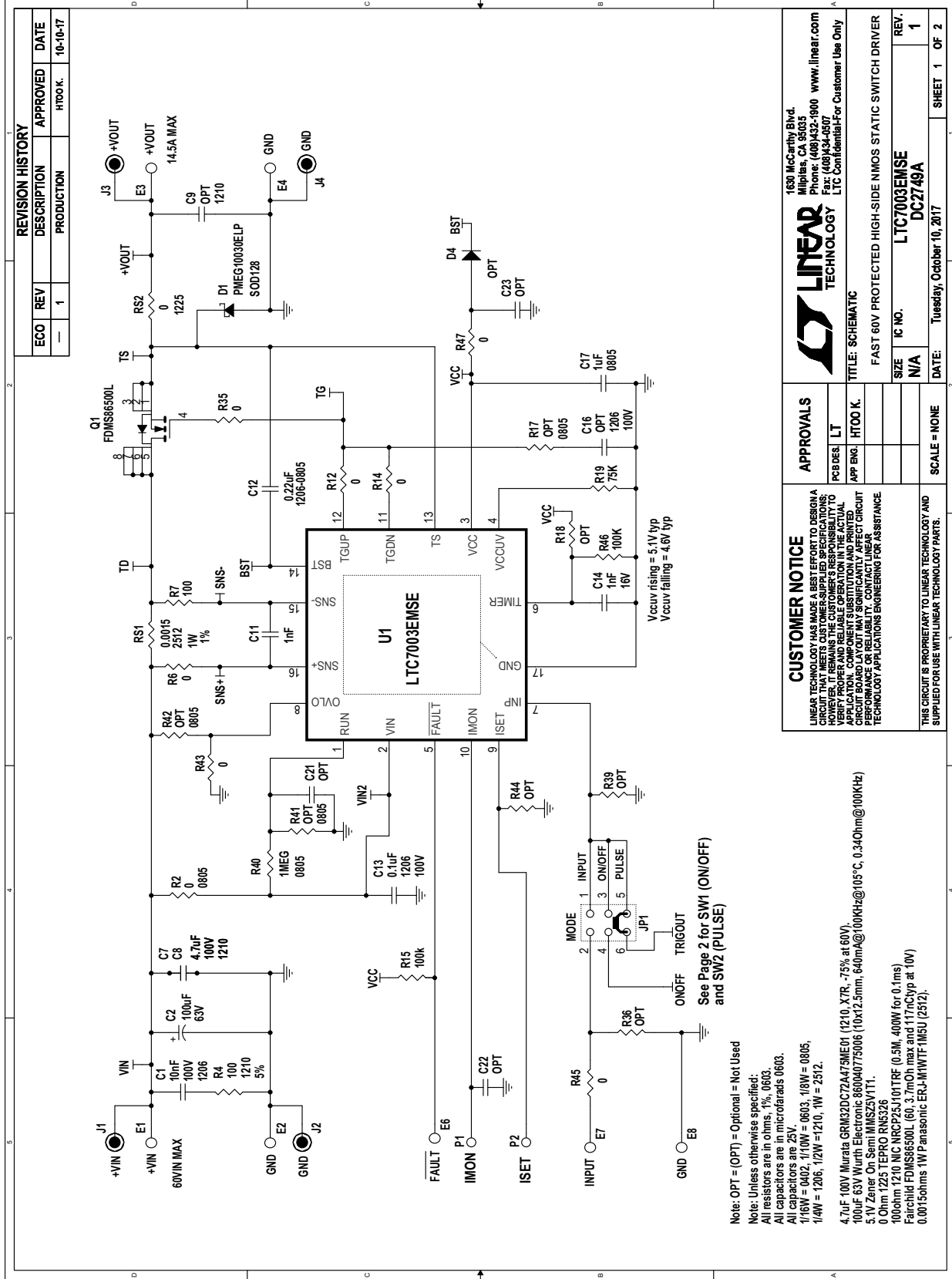

SCHEMATIC DIAGRAM

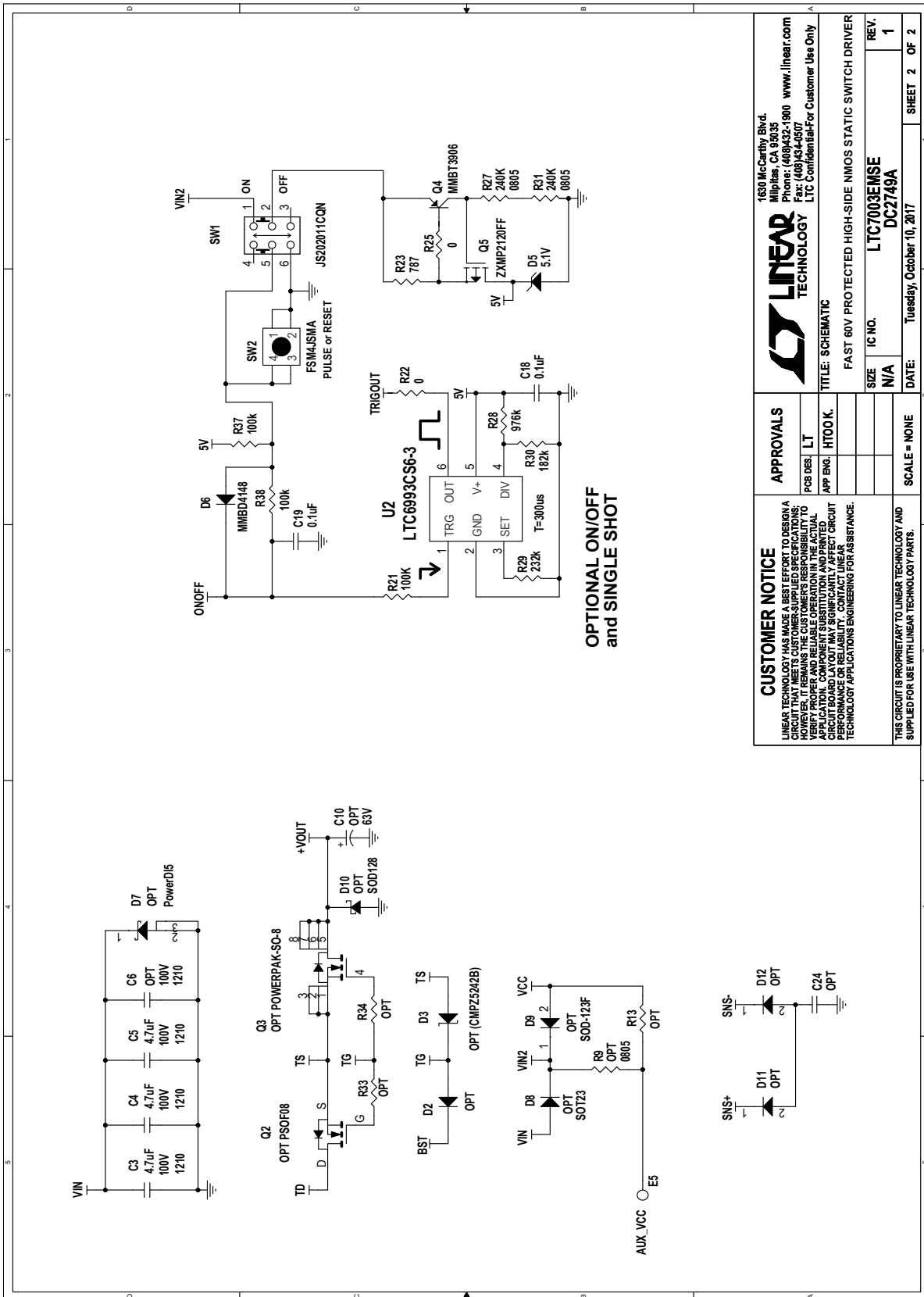

CUSTOMER NOTICE LINEAR TECHNOLOGY HAS MADE A BEST EFFORT TO DESIGN A CIRCUIT THAT MEETS CUSTOMER-SUPPLIED SPECIFICATIONS. HOWEVER, CUSTOMERS ARE RESPONSIBLE FOR VERIFYING THAT THE CIRCUIT MEETS THEIR APPLICATION REQUIREMENTS. CUSTOMERS SHOULD VERIFY PROPER AND RELIABLE OPERATION WITH THE ACTUAL APPLICATION COMPONENT SUBSTITUTION AND PRINTED CIRCUIT BOARD LAYOUT. THIS CANNOT BE GUARANTEED. CUSTOMER BOARD LAYOUT MAY SIGNIFICANTLY AFFECT CIRCUIT PERFORMANCE. CUSTOMERS SHOULD CONTACT LINEAR TECHNOLOGY APPLICATIONS ENGINEERING FOR ASSISTANCE.		APPROVALS PCB DES. LT APP. ENG. HTOOK.K.	
CUSTOMER NOTICE LINEAR TECHNOLOGY HAS MADE A BEST EFFORT TO DESIGN A CIRCUIT THAT MEETS CUSTOMER-SUPPLIED SPECIFICATIONS. HOWEVER, CUSTOMERS ARE RESPONSIBLE FOR VERIFYING THAT THE CIRCUIT MEETS THEIR APPLICATION REQUIREMENTS. CUSTOMERS SHOULD VERIFY PROPER AND RELIABLE OPERATION WITH THE ACTUAL APPLICATION COMPONENT SUBSTITUTION AND PRINTED CIRCUIT BOARD LAYOUT. THIS CANNOT BE GUARANTEED. CUSTOMER BOARD LAYOUT MAY SIGNIFICANTLY AFFECT CIRCUIT PERFORMANCE. CUSTOMERS SHOULD CONTACT LINEAR TECHNOLOGY APPLICATIONS ENGINEERING FOR ASSISTANCE.		SCALE = NONE	
THIS CIRCUIT IS PROPRIETARY TO LINEAR TECHNOLOGY AND SUPPLIED FOR USE WITH LINEAR TECHNOLOGY PARTS.		TITLE: SCHEMATIC	
1630 McCarty Blvd. Millsides, CA 95035 Phone: (408)432-1900 www.linear.com Fax: (408)434-0507 LTC Confidential-For Customer Use Only		FAST 60V PROTECTED HIGH-SIDE NMOS STATIC SWITCH DRIVER	
SIZE	IC NO.	REV.	
N/A	LTC7003EMSE	1	
DATE:	Tuesday, October 10, 2017	SHEET	2 OF 2



ESD Caution

ESD (electrostatic discharge) sensitive device. Charged devices and circuit boards can discharge without detection. Although this product features patented or proprietary protection circuitry, damage may occur on devices subjected to high energy ESD. Therefore, proper ESD precautions should be taken to avoid performance degradation or loss of functionality.

Legal Terms and Conditions

By using the evaluation board discussed herein (together with any tools, components documentation or support materials, the "Evaluation Board"), you are agreeing to be bound by the terms and conditions set forth below ("Agreement") unless you have purchased the Evaluation Board, in which case the Analog Devices Standard Terms and Conditions of Sale shall govern. Do not use the Evaluation Board until you have read and agreed to the Agreement. Your use of the Evaluation Board shall signify your acceptance of the Agreement. This Agreement is made by and between you ("Customer") and Analog Devices, Inc. ("ADI"), with its principal place of business at One Technology Way, Norwood, MA 02062, USA. Subject to the terms and conditions of the Agreement, ADI hereby grants to Customer a free, limited, personal, temporary, non-exclusive, non-sublicensable, non-transferable license to use the Evaluation Board FOR EVALUATION PURPOSES ONLY. Customer understands and agrees that the Evaluation Board is provided for the sole and exclusive purpose referenced above, and agrees not to use the Evaluation Board for any other purpose. Furthermore, the license granted is expressly made subject to the following additional limitations: Customer shall not (i) rent, lease, display, sell, transfer, assign, sublicense, or distribute the Evaluation Board; and (ii) permit any Third Party to access the Evaluation Board. As used herein, the term "Third Party" includes any entity other than ADI, Customer, their employees, affiliates and in-house consultants. The Evaluation Board is NOT sold to Customer; all rights not expressly granted herein, including ownership of the Evaluation Board, are reserved by ADI. CONFIDENTIALITY. This Agreement and the Evaluation Board shall all be considered the confidential and proprietary information of ADI. Customer may not disclose or transfer any portion of the Evaluation Board to any other party for any reason. Upon discontinuation of use of the Evaluation Board or termination of this Agreement, Customer agrees to promptly return the Evaluation Board to ADI. ADDITIONAL RESTRICTIONS. Customer may not disassemble, decompile or reverse engineer chips on the Evaluation Board. Customer shall inform ADI of any occurred damages or any modifications or alterations it makes to the Evaluation Board, including but not limited to soldering or any other activity that affects the material content of the Evaluation Board. Modifications to the Evaluation Board must comply with applicable law, including but not limited to the RoHS Directive. TERMINATION. ADI may terminate this Agreement at any time upon giving written notice to Customer. Customer agrees to return to ADI the Evaluation Board at that time. LIMITATION OF LIABILITY. THE EVALUATION BOARD PROVIDED HEREUNDER IS PROVIDED "AS IS" AND ADI MAKES NO WARRANTIES OR REPRESENTATIONS OF ANY KIND WITH RESPECT TO IT. ADI SPECIFICALLY DISCLAIMS ANY REPRESENTATIONS, ENDORSEMENTS, GUARANTEES, OR WARRANTIES, EXPRESS OR IMPLIED, RELATED TO THE EVALUATION BOARD INCLUDING, BUT NOT LIMITED TO, THE IMPLIED WARRANTY OF MERCHANTABILITY, TITLE, FITNESS FOR A PARTICULAR PURPOSE OR NON-INFRINGEMENT OF INTELLECTUAL PROPERTY RIGHTS. IN NO EVENT WILL ADI AND ITS LICENSORS BE LIABLE FOR ANY INCIDENTAL, SPECIAL, INDIRECT, OR CONSEQUENTIAL DAMAGES RESULTING FROM CUSTOMER'S POSSESSION OR USE OF THE EVALUATION BOARD, INCLUDING BUT NOT LIMITED TO LOST PROFITS, DELAY COSTS, LABOR COSTS OR LOSS OF GOODWILL. ADI'S TOTAL LIABILITY FROM ANY AND ALL CAUSES SHALL BE LIMITED TO THE AMOUNT OF ONE HUNDRED US DOLLARS (\$100.00). EXPORT. Customer agrees that it will not directly or indirectly export the Evaluation Board to another country, and that it will comply with all applicable United States federal laws and regulations relating to exports. GOVERNING LAW. This Agreement shall be governed by and construed in accordance with the substantive laws of the Commonwealth of Massachusetts (excluding conflict of law rules). Any legal action regarding this Agreement will be heard in the state or federal courts having jurisdiction in Suffolk County, Massachusetts, and Customer hereby submits to the personal jurisdiction and venue of such courts. The United Nations Convention on Contracts for the International Sale of Goods shall not apply to this Agreement and is expressly disclaimed.