

LT3585EDDB -0/-1/-2/-3  
 Photoflash Charger with Ad-  
 justable Input Current and

## DESCRIPTION

**WARNING!**
**Do not look directly at flash.**

This circuit produces light that can damage eyes.

**WARNING!**
**Lethal voltages are present on the circuit board.**

Do not operate the assembly unless you are trained to handle high voltage circuits

Demonstration circuit 988 is a Photoflash Charger with Adjustable Input Current and IGBT Driver featuring the LT3585EDDB-x family of products. It demonstrates a complete xenon photoflash solution, including the photoflash capacitor, flash tube and trigger circuit, along with an input current adjust capability. An on-board microcontroller generates the necessary signals to produce an on-demand flash, red-eye sequence, and flash capacitor refresh.

The demonstration board comes in four variants. DC988-A uses the LT3585EDD-0, while DC988-B,

DC988-C and DC988-D use the LT3585EDD-1, LT3585EDD-2, LT3585EDD-3, respectively.

The LT3585-x are highly integrated devices designed to charge photoflash capacitors in digital and film cameras. Its unique control technique allows for the use of extremely small transformers. Each part contains an on-chip high voltage NPN power switch. Output voltage detection is completely contained within the part, eliminating the need for any discrete zener diodes or resistors for high voltage output sensing. The output can be adjusted by simply changing the turns ratio of the transformer.

The CHRG/IADJ pin gives full control of the part to the user. Driving CHRG/IADJ lows puts the part in shutdown. The CHRG/IADJ pin can also be used to reduce the current of the charger, useful in extending battery life. The DONE pin indicates when the part has completed charging.

**Design files for this circuit board are available. Call the LTC factory.**

 , LTC, and LT are registered trademarks of Linear Technology Corporation.

## PERFORMANCE SUMMARY Specifications are at TA = 25°C

SYMBOL	PARAMETER	CONDITIONS	MIN	TYP	MAX	UNITS
VBAT	VBAT Voltage Range	VIN = 2.8V – 4.2V	1.8		4.2	V
VIN	VIN Voltage Range	VBAT = 1.8V – 4.2V	2.8		4.2	V
VOUT	Output Voltage	VIN = 2.8V – 4.2V, VBAT = 1.8V – 4.2V		320		V
TCHARGE	Charge Time	LT3585-3, VBAT = 3.6V, CHRG/IADJ high LT3585-0, VBAT = 3.6V, CHRG/IADJ high LT3585-1, VBAT = 3.6V, CHRG/IADJ high LT3585-2, VBAT = 3.6V, CHRG/IADJ high		468 600 1180 779		mS
TCHAREG(R)	Charge time (Reduced current)	LT3585-3, VBAT = 3.6V, CHRG/IADJ hi-Z LT3585-0, VBAT = 3.6V, CHRG/IADJ hi-Z LT3585-1, VBAT = 3.6V, CHRG/IADJ hi-Z		890 1237 2547		mS

# LT3585EDDB-0/-1/-2/-3

## PERFORMANCE SUMMARY Specifications are at TA = 25°C

SYMBOL	PARAMETER	CONDITIONS	MIN	TYP	MAX	UNITS
		LT3585-2, VBAT = 3.6V, CHRGI/ADJ hi-Z		1550		

## QUICK START PROCEDURE

**WARNING!**

**Do not look directly at flash.**

This circuit produces light that can damage eyes.

**WARNING!**

**Lethal voltages are present on the circuit board.**

Do not operate the assembly unless you are trained to handle high voltage circuits

Demonstration circuit 988 is easy to set up to evaluate the performance of the LT3585EDDB-x. For proper measurement equipment setup and test, refer to figure 1 and follow the procedure below:

1. Set the jumper at JP1 across the DAT and MCLR pins.
2. Set the jumper at JP2 to the HIGH CURRENT position.
3. With the power supply disconnected from DC988, set the VBAT voltage between 1.8V to 4.2V. Set the VIN voltage between 2.8V and 4.2V. Turn off the power supply.
4. Connect the power supply to DC988, referring to the connection diagram given in figure 1.
5. Turn on the power supply, verifying that the VIN and VBAT voltages are correctly set.
6. Press the ON/OFF button once. The READY/CHARGE LED should glow red as the LT3585 charges the output capacitor and then glow green when it is done.
7. To flash the xenon tube, verify that the READY/CHARGE LED is green. Avoid looking directly at the xenon flash tube and press the FLASH button once. After the tube flashes, the READY/CHARGE LED should turn red as the LT3585 replenishes the charge in the flash capacitor.
8. To generate a red-eye sequence, verify that the READY/CHARGE LED is green. Avoid looking directly at the xenon flash tube and press the REDEYE button once. After the flash sequence is over, the READY/CHARGE LED should turn red as the LT3585 replenishes the charge in the flash capacitor.
9. When finished testing, press the ON/OFF switch once. This flashes the xenon tube, discharging the flash capacitor and shuts down the LT3585. The output capacitor is not completely discharged when this operation is complete. 50V or more may be left on the capacitor, so the user is cautioned to avoid physical contact with the flash tube circuitry at all times. The flash tube circuitry consists of the secondary of T1, D1, C2, R3, R10, C3, T2, FT1, and Q1.
10. If low current charging is desired, move the jumper at JP2 to the LOW CURRENT position and repeat steps 4-9 as necessary.
11. Monitor the DONE, CHARGE, and TRIGGER signals by using the provided test points. Do not make measurements from under the protective cover.

## OPERATION

The microcontroller has been programmed to scan the interface button with a ½ second debounce routine. You need to press and hold the buttons down for at least ½ second in order for the microcontroller to recognize a valid button event.

It is assumed that DC988 will be tested with power provided from an external source, such as a lab bench supply. Under such an operating condition, the wire length between the DC988 board and the power supply terminals can be several feet and the line loss may be excessive. For this reason, CIN has been added to the board at the input terminals to attenuate the ground shifting associated with pulling the main switch current through the wires connecting to the power supply. This capacitor would generally not be required in a battery powered portable application, where the battery would be physically located close to the LT3585 and the impedance of the connection is low.

The on-board microcontroller may be disabled by removing the VIN and VBAT voltages and moving the JP1 jumper to short the GND and CLK pins. Apply power to the VIN and VBAT terminals and press the ON/OFF button once. The READY/CHARGE LED should blink red. The user can now charge the output capacitor and activate the flash tube by applying the appropriate signals to the CHARGE and TRIGGER test points. The timing can be validated by monitoring these and the DONE signal. Please refer to the LT3585 data sheet for detailed signal requirements.

The input current of an LT3585-x circuit can be reduced by changing the voltage of the CHRG/IADJ pin. When this pin is driven high, the charge cycle starts. If the CHRG/IADJ pin is put into a high impedance state (tri-state), the LT3585 will enter a low charging current mode. For further details on this function, please refer to the LT3585 data sheet.

To enable the reduced charging current function on the DC988 demo board, simply move the JP2 jumper the LOW CURRENT position before starting the next output capacitor charge cycle. This may be done while the DC988 board is still powered. With the jumper in this position, the microcontroller will tri-state signal to the LT3585 CHRG/IADJ input shortly after driving the signal high for a brief period.

**WARNING!**

**Do not look directly at flash.**

This circuit produces light that can damage eyes.

**WARNING!**

**Lethal voltages are present on the circuit board.**

Do not operate the assembly unless you are trained to handle high voltage circuits

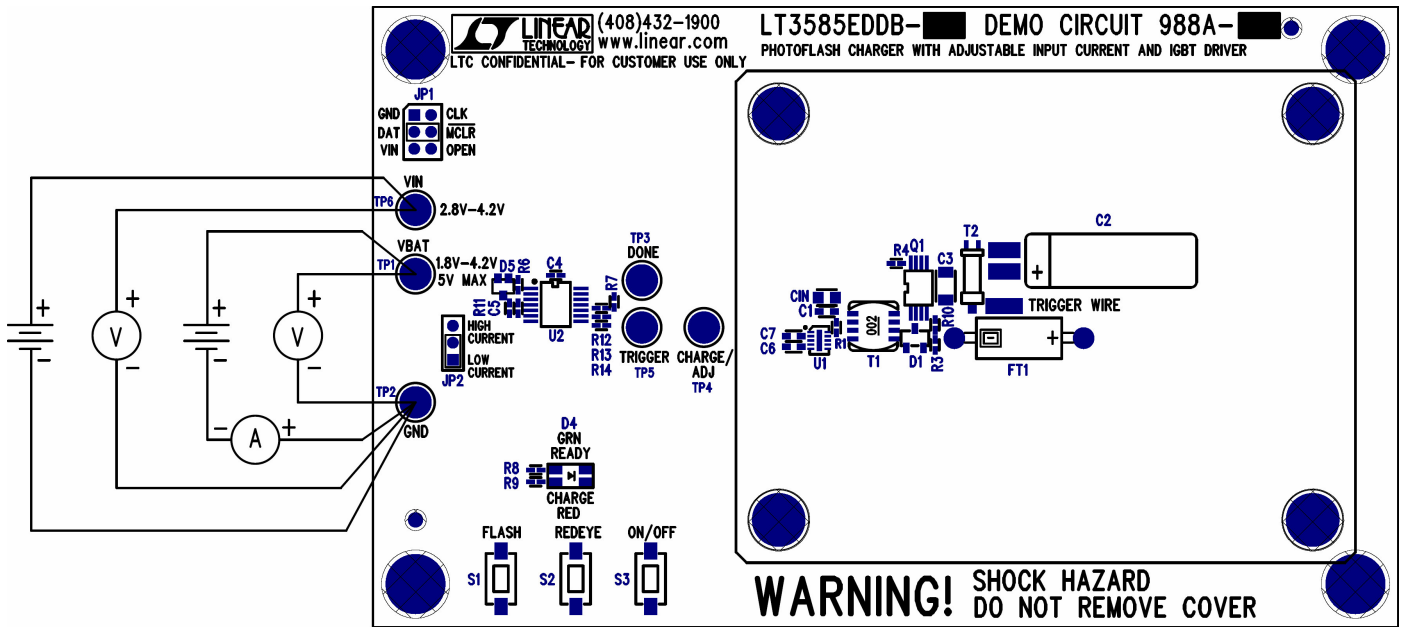
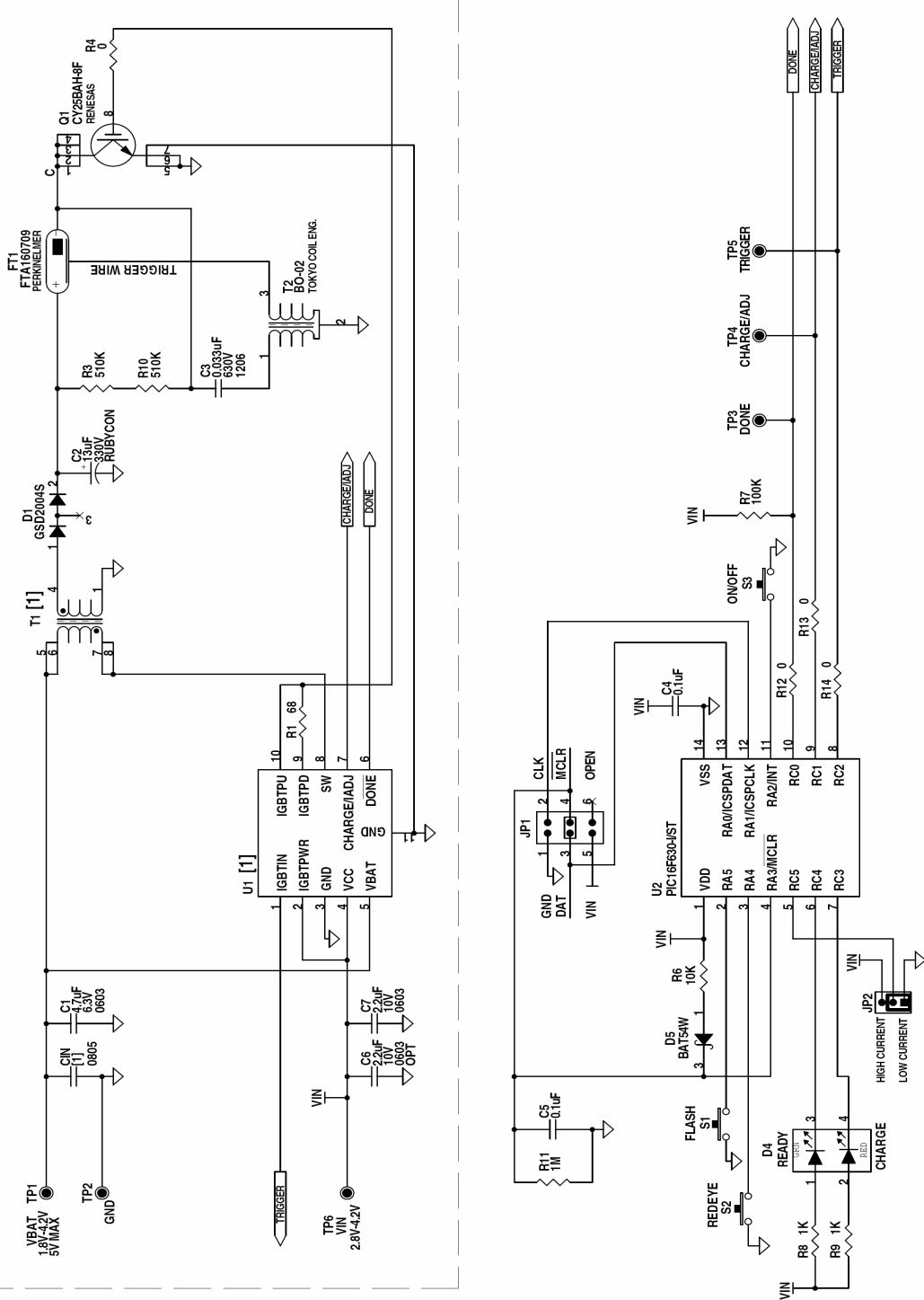

Figure 1. Proper Measurement Equipment Setup

**WARNING! SHOCK HAZARD  
DO NOT REMOVE COVER**



**FOR ASSEMBLY**

VERSION	U1	CIN	T1
-A	LT3585EDDB-0	CAP, 0805 10uF 20% 6.3V XSR	LDT565630T-001
-B	LT3585EDDB-1	CAP, 0805 4.7uF 10% 6.3V XSR	LDT565630T-002
-C	LT3585EDDB-2	CAP, 0805 10uF 20% 6.3V XSR	LDT565630T-003
-D	LT3585EDDB-3	CAP, 0805 22uF 20% 6.3V XSR	LDT565630T-041

[1]

**LINEAR TECHNOLOGY**  
1630 McCarthy Blvd.  
Milpitas, CA 95035  
Phone: (909)422-1000  
Fax: (909)422-1607  
LTC Confidential For Customer Use Only

**CUSTOMER NOTICE**  
LINEAR TECHNOLOGY HAS MADE A BEST EFFORT TO DESIGN A CIRCUIT THAT MEETS CUSTOMER-SUPPLIED SPECIFICATIONS; HOWEVER, IT REMAINS THE CUSTOMER'S RESPONSIBILITY TO VERIFY PROPER AND RELIABLE OPERATION IN THE ACTUAL APPLICATION. COMPONENT SUBSTITUTION AND PRINTED CIRCUIT BOARD LAYOUT MAY SIGNIFICANTLY AFFECT CIRCUIT PERFORMANCE OR RELIABILITY. CONTACT LINEAR TECHNOLOGY APPLICATIONS ENGINEERING FOR ASSISTANCE.

**CONTRACT NO.**  
**APPROVALS**  
**DRAWN:** KIM T.  
**CHECKED:**  
**APPROVED:**  
**ENGINEER:** DAVID NG  
**DESIGNER:**

**TITLE:** SCHEMATIC  
**PHOTO FLASH CHARGER WITH ADJUSTABLE INPUT CURRENT AND IGBT DRIVER**

<b>SIZE</b>	A	<b>REV</b>	A-1
<b>DWG NO.</b>	DC988A-1 * LT3585EDDB-0/-1/-2/-3		
<b>DATE:</b>	Tuesday, August 01, 2006	<b>SHEET</b>	1 OF 1