

Dual Serial 12-Bit Multiplying DAC

FEATURES

- **DNL and INL Over Temperature: $\pm 0.5\text{LSB}$ Max**
- **Gain Error: $\pm 1\text{LSB}$ Max**
- **Low Supply Current: $10\mu\text{A}$ Max**
- 4-Quadrant Multiplication
- Power-On Reset
- Asynchronous Clear Input
- Daisy-Chain 3-Wire Serial Interface
- 16-Pin Narrow SO and PDIP Packages

APPLICATIONS

- Process Control and Industrial Automation
- Software Controlled Gain Adjustment
- Digitally Controlled Filter and Power Supplies
- Automatic Test Equipment

DESCRIPTION

The LTC[®]1590 is a dual, serial input 12-bit multiplying digital-to-analog converter (DAC). It includes two current output multiplying CMOS DACs and an easy SPI compatible serial interface with daisy-chain output. An asynchronous $\overline{\text{CLR}}$ pin sets both DACs to zero scale.

Excellent accuracy, stability and versatility are combined with the smallest package available for a dual 12-bit multiplying DAC.

Parts are available in 16-pin PDIP and narrow SO packages and are specified over the commercial and industrial temperature ranges.

 LTC and LT are registered trademarks of Linear Technology Corporation.

TYPICAL APPLICATION

Dual 12-Bit 2-Quadrant Multiplying DAC

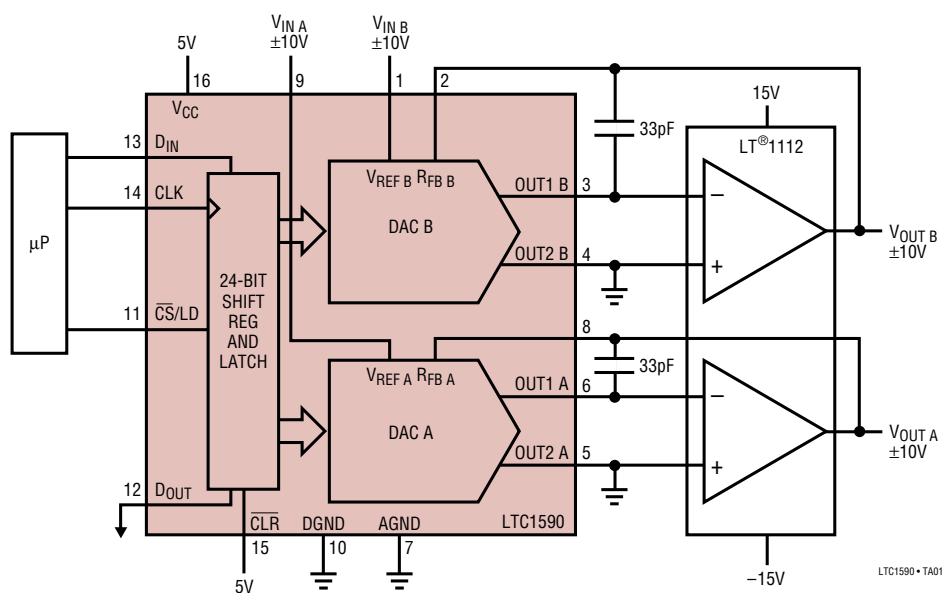

Integral Nonlinearity Over Temperature DAC A

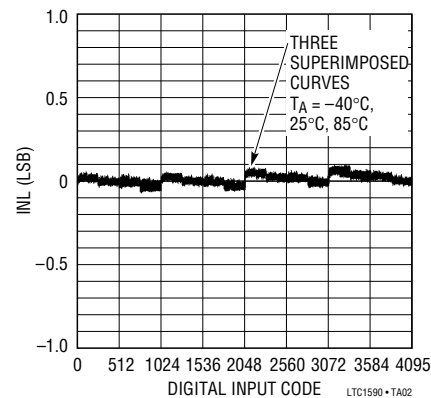

Integral Nonlinearity Over Temperature DAC B

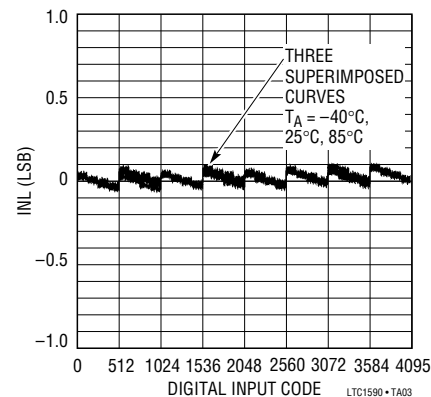

ABSOLUTE MAXIMUM RATINGS

| | |
|--|--------------------------|
| V_{CC} to AGND | -0.5V to 7V |
| V_{CC} to DGND | -0.5V to 7V |
| AGND to DGND | $V_{CC} + 0.5V$ |
| DGND to AGND | $V_{CC} + 0.5V$ |
| V_{REF} to AGND | $\pm 25V$ |
| R_{FB} to AGND | $\pm 25V$ |
| Digital Inputs to DGND | -0.5V to $V_{CC} + 0.5V$ |
| V_{OUT1} , V_{OUT2} to AGND | -0.5V to $V_{CC} + 0.5V$ |
| Maximum Junction Temperature | 150°C |
| Operating Temperature Range | |
| LTC1590C | 0°C to 70°C |
| LTC1590I | -40°C to 85°C |
| Storage Temperature Range | -65°C to 150°C |
| Lead Temperature (Soldering, 10 sec) | 300°C |

PACKAGE/ORDER INFORMATION

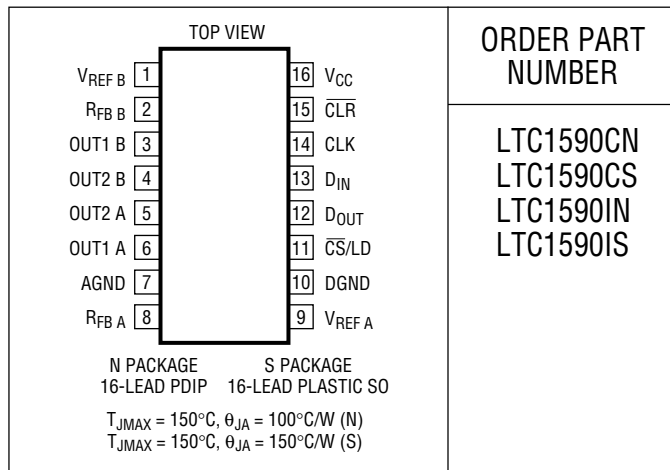

ORDER PART NUMBER

LTC1590CN
LTC1590CS
LTC1590IN
LTC1590IS

Consult factory for Military grade parts.

ELECTRICAL CHARACTERISTICS

$V_{CC} = 4.5V$ to $5.5V$, $V_{REF} = 10V$, $V_{OUT1} = V_{OUT2} = AGND = DGND = 0V$, $T_A = T_{MIN}$ to T_{MAX} , unless otherwise noted.

| SYMBOL | PARAMETER | CONDITIONS | MIN | TYP | MAX | UNITS | |
|--------------------------------|--|---|-----|--------------|-------------|------------------|-----|
| Accuracy | | | | | | | |
| | Resolution | | 12 | | | Bits | |
| INL | Integral Nonlinearity | (Note 1) | | | ± 0.5 | LSB | |
| DNL | Differential Nonlinearity | Guaranteed Monotonic, T_{MIN} to T_{MAX} | | | ± 0.5 | LSB | |
| GE | Gain Error | (Note 2), $T_A = 25^{\circ}C$ T_{MIN} to T_{MAX} | | | ± 1 | LSB | |
| | | | | | ± 2 | LSB | |
| | Gain Temperature Coefficient | (Note 3) $\Delta Gain/\Delta Temperature$ | | 1 | 5 | ppm/ $^{\circ}C$ | |
| $I_{LEAKAGE}$ | OUT1 A, OUT1 B Leakage Current | (Note 4), $T_A = 25^{\circ}C$ T_{MIN} to T_{MAX} | | | ± 5 | nA | |
| | | | | | ± 25 | nA | |
| | Zero-Scale Error | $T_A = 25^{\circ}C$ T_{MIN} to T_{MAX} | | | ± 0.03 | LSB | |
| | | | | | ± 0.15 | LSB | |
| PSRR | Power Supply Rejection | $V_{CC} = 5V \pm 10\%$ | | ± 0.0001 | ± 0.002 | %/% | |
| Reference Input | | | | | | | |
| R_{REF} | V_{REF} Input Resistance | | 8 | 11 | 15 | k Ω | |
| | V_{REFA} , V_{REFB} Input Resistance Match | | | | 3 | % | |
| AC Performance (Note 3) | | | | | | | |
| | Digital-to-Analog Glitch Impulse | (Notes 5, 6) | | 1 | | nV-s | |
| | Multiplying Feedthrough Error | (Note 11) | | -89 | -80 | dB | |
| | Output Current Settling Time | (Note 5) To 0.01% for Full-Scale Change | | 0.3 | 0.8 | μs | |
| | Channel-to-Channel Isolation | (Note 7) | | | -90 | dB | |
| | Digital Crosstalk | (Notes 5, 8) | | 1 | | nV-s | |
| | Output Noise Voltage Density | (Note 9) | | 13 | | nV/ \sqrt{Hz} | |
| THD | Total Harmonic Distortion | (Note 10) | | | -108 | -92 | dB |
| | | | | | 1 | | MHz |

ELECTRICAL CHARACTERISTICS

$V_{CC} = 4.5V$ to $5.5V$, $V_{REF} = 10V$, $V_{OUT1} = V_{OUT2} = AGND = DGND = 0V$, $T_A = T_{MIN}$ to T_{MAX} , unless otherwise noted.

| SYMBOL | PARAMETER | CONDITIONS | MIN | TYP | MAX | UNITS | |
|-------------------------------|------------------------------------|--|--------|----------|----------|----------|----|
| Analog Outputs | | | | | | | |
| C_{OUT} | Output Capacitance (Note 3) | DAC Register Loaded to All 1s DAC Register Loaded to All 0s | ● ● | 60 30 | 90 60 | pF pF | |
| Digital Input | | | | | | | |
| V_{IH} | Digital Input High Voltage | | ● | 2.4 | | V | |
| V_{IL} | Digital Input Low Voltage | | ● | | 0.8 | V | |
| I_{IN} | Digital Input Current | | ● | 0.001 | ±1 | μA | |
| C_{IN} | Digital Input Capacitance | (Note 3) $V_{IN} = 0V$ | ● | | 8 | pF | |
| Digital Output | | | | | | | |
| V_{OH} | Digital Output High Voltage | $I_{OH} = 200\mu A$ | ● | 4 | | V | |
| V_{OL} | Digital Output Low Voltage | $I_{OH} = 1.6mA$ | ● | | 0.4 | V | |
| Timing Characteristics | | | | | | | |
| t_1 | D_{IN} to CLK Setup Time | | ● | 50 | | ns | |
| t_2 | D_{IN} to CLK Setup Hold Time | | ● | 0 | | ns | |
| t_3 | CLK High Time | | ● | 40 | | ns | |
| t_4 | CLK Low Time | | ● | 40 | | ns | |
| t_5 | \overline{CS}/LD High Time | | ● | 50 | | ns | |
| t_6 | LSB CLK to \overline{CS}/LD | | ● | 40 | | ns | |
| t_7 | \overline{CS}/LD Low to CLK High | | ● | 20 | | ns | |
| t_8 | CLK Low to \overline{CS}/LD Low | | ● | 20 | | ns | |
| t_9 | CLK to D_{OUT} Delay | | ● | 10 | 160 | ns | |
| Power Supply | | | | | | | |
| V_{CC} | Operating Supply Range | | ● | 4.5 | 5 | 5.5 | V |
| I_{CC} | Supply Current | Digital Inputs = 0V or V_{CC} | ● | | 10 | | μA |

The ● denotes specifications which apply over the full operating temperature range.

Note 1: $\pm 0.5LSB = \pm 0.012\%$ of full scale.

Note 2: Using internal feedback resistor.

Note 3: Guaranteed by design, not subject to test.

Note 4: I_{OUT1} with DAC register loaded with all 0s.

Note 5: $OUT1$ load = 100Ω in parallel with $13pF$.

Note 6: $V_{REF} = 0V$. DAC register contents changed from all 0s to all 1s or all 1s to all 0s.

Note 7: DAC A output with $V_{REF A} = 0V$ and $V_{REF B} = 10kHz$ $20V_{P-P}$, or DAC B output with $V_{REF B} = 0V$, $V_{REF A} = 10kHz$ $20V_{P-P}$. Both DAC registers loaded with all 1s.

Note 8: Glitch on DAC A or DAC B output when the other DAC makes a full-scale transition.

Note 9: 10Hz to 100kHz. Calculation from $e_n = \sqrt{4KTRB}$ where: K = Boltzmann constant (J/K°); R = resistance (Ω); T = resistor temperature (°K); B = bandwidth (Hz).

Note 10: $V_{REF} = 6V_{RMS}$ at 1kHz. DAC register loaded with all 1s, using LT[®]1124 op amp.

Note 11: $V_{REF} = \pm 10V$, 10kHz sine wave, DAC register loaded with all 0s, using LT1358 op amp.

Note 12: -3dB bandwidth using LT1358 op amp.

TYPICAL PERFORMANCE CHARACTERISTICS

Full-Scale Settling Waveform

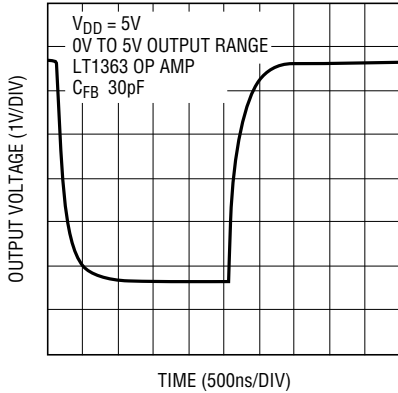

1590 G12

Integral Nonlinearity (INL)

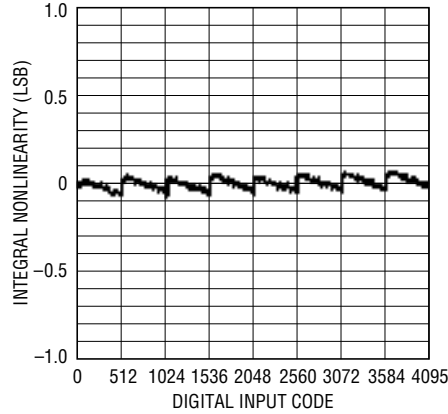

1590 G02

Differential Nonlinearity (DNL)

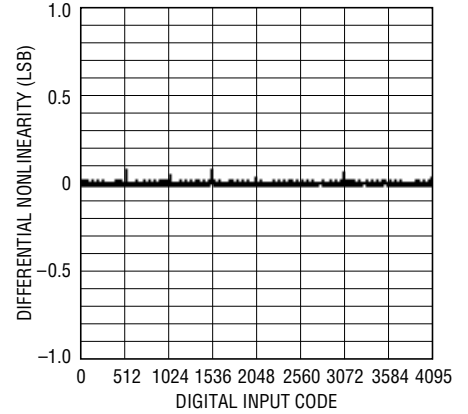

1590 G03

Multiplying Mode Signal-to-(Noise + Distortion) vs Frequency

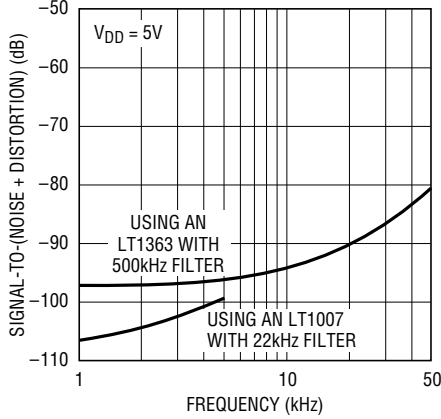

1590 G10

Integral Nonlinearity vs Reference Voltage

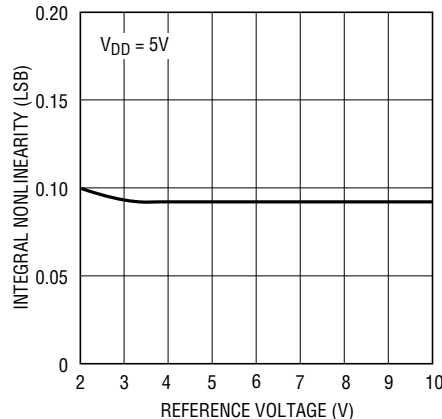

1590 G05

Differential Nonlinearity vs Reference Voltage

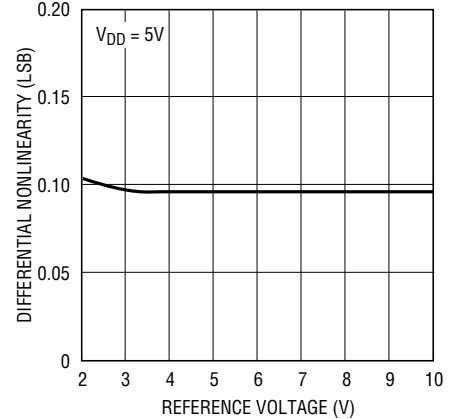

1590 G06

Multiplying Mode Frequency Response vs Digital Code

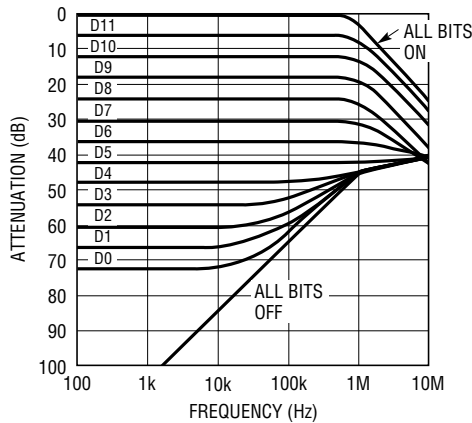

1590 G07

Integral Nonlinearity vs Supply Voltage

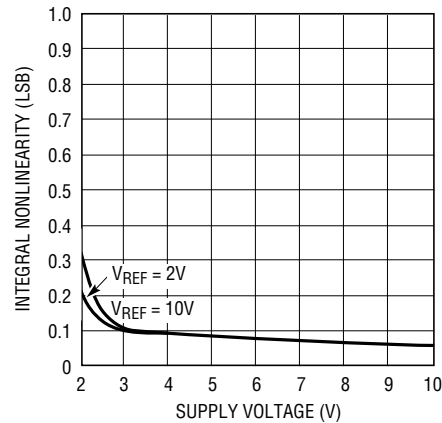

1590 G08

Differential Nonlinearity vs Supply Voltage

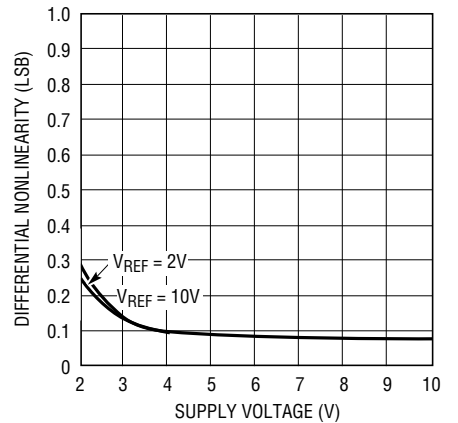

1590 G09

TYPICAL PERFORMANCE CHARACTERISTICS

Midscale Glitch Impulse

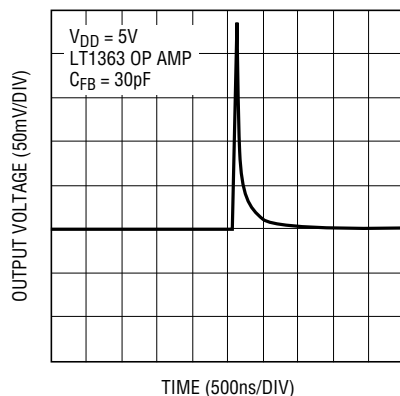

1590 G11

Logic Threshold vs Supply Voltage

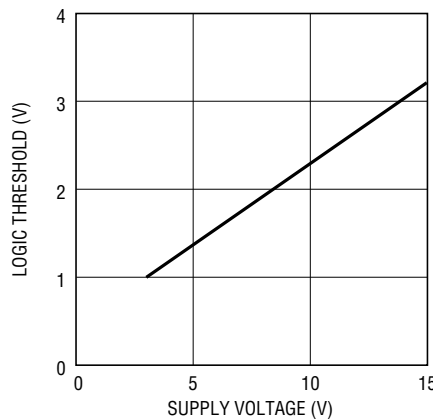

1590 G04

Supply Current vs Logic Input Voltage

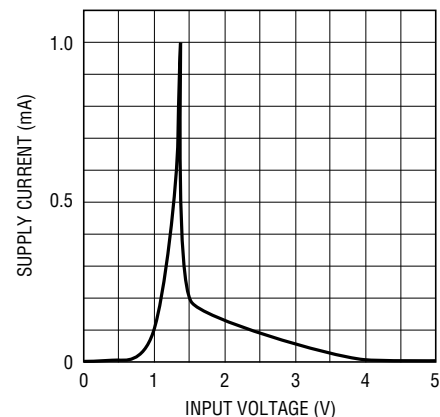

1590 G01

PIN FUNCTIONS

V_{REF B}, V_{REF A} (Pins 1, 9): Reference Inputs for DAC A/B. Typically $\pm 10V$, accepts up to $\pm 25V$.

R_{FB B}, R_{FB A} (Pins 2, 8): Feedback Resistors for DAC A/B. Normally tied to the output of current to voltage converter op amp. Typically swings to $\pm 10V$. Swings from $0V$ to $-V_{REF}$.

OUT1 B, OUT1 A (Pins 3, 6): True Current Output for DAC A/B. Normally tied to inverting input of current to voltage converter op amp.

OUT2 B, OUT2 A (Pins 4, 5): Complement Current Output for DAC A/B. Normally tied to ground.

AGND (Pin 7): Analog Ground Pin. Tie to ground.

DGND (Pin 10): Digital Ground Pin. Tie to ground.

$\overline{CS/LD}$ (Pin 11): The Serial Interface Enable and Load Control Input. When $\overline{CS/LD}$ is low the CLK signal is

enabled so the data can be clocked in. When $\overline{CS/LD}$ is pulled high, data is loaded from the shift register into the DAC register, updating the DAC output.

D_{OUT} (Pin 12): The Serial Data Output. Data becomes valid on the rising edge of the CLK.

D_{IN} (Pin 13): The Serial Data Input. Data on the D_{IN} pin is latched into the shift register on the rising edge of the serial clock. Data is loaded as one 24-bit word. The first 12 bits are for DAC A, MSB-first and the second 12 bits are for DAC B, MSB-first.

CLK (Pin 14): The Serial Interface Clock Input.

\overline{CLR} (Pin 15): The Clear Pin for the DAC. Clears both DACs to zero scale when pulled low. This pin should be tied to V_{CC} for normal operation.

V_{CC} (Pin 16): The Positive Supply Input. $4.5 \leq V_{CC} \leq 5.5V$. Requires a bypass capacitor to ground.

BLOCK DIAGRAM

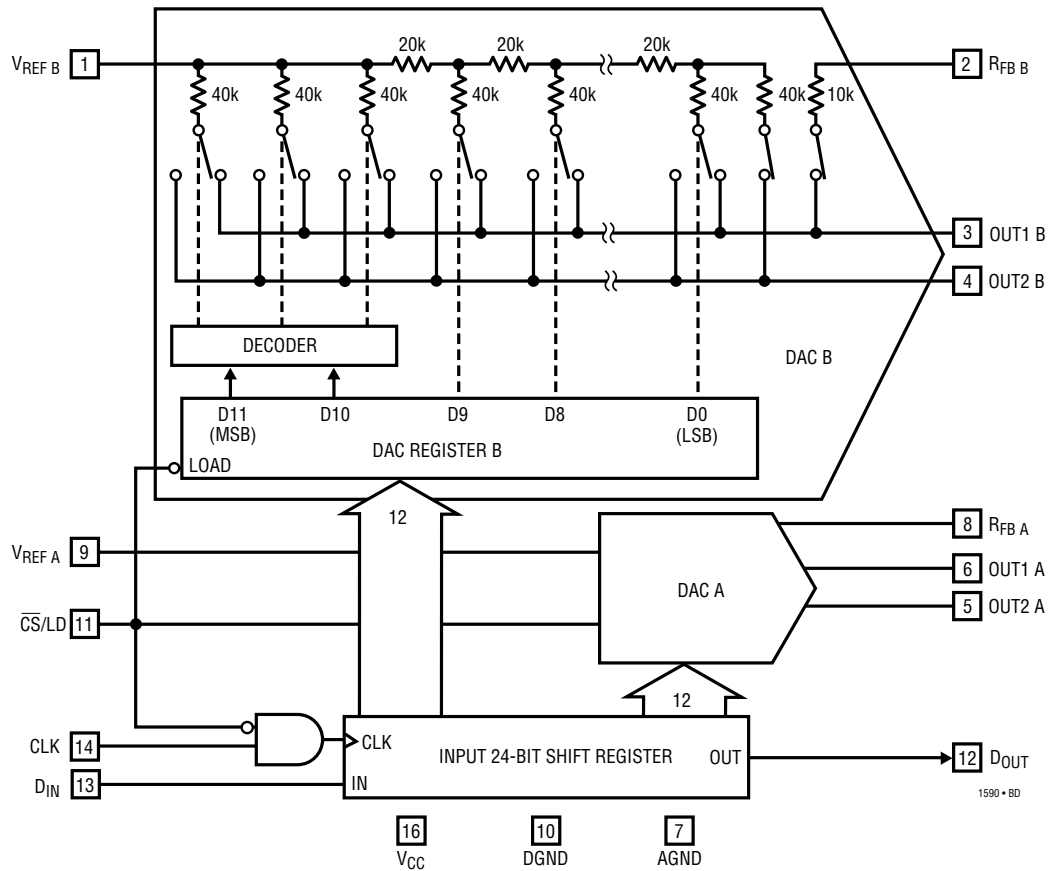

TIMING DIAGRAMS

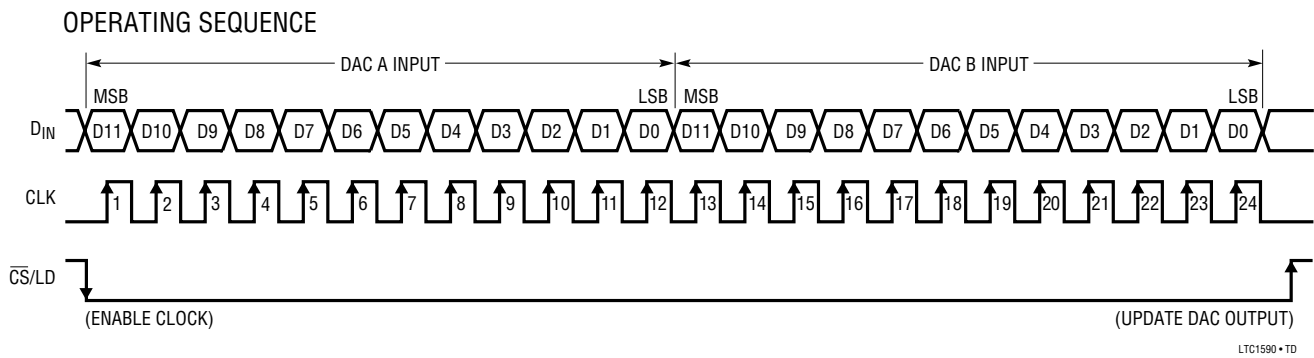

TIMING DIAGRAMS

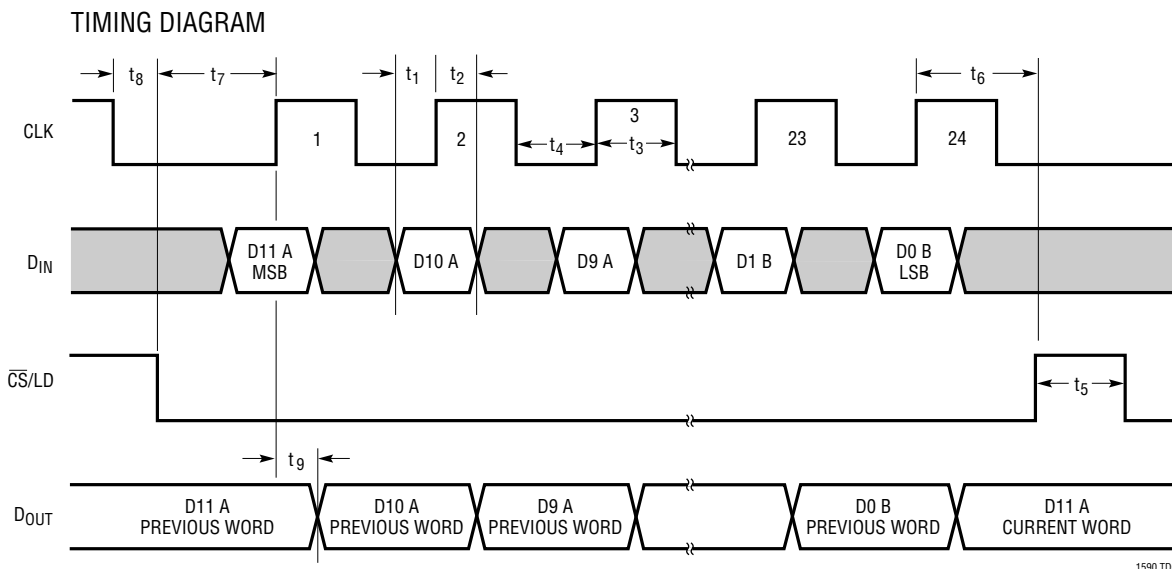

APPLICATIONS INFORMATION

Description

The LTC1590 is a dual 12-bit multiplying DAC that has serial inputs and current outputs. It uses precision R/2R resistor ladder technology to provide exceptional linearity and stability. The device operates from a single 5V supply and provides a $\pm 10V$ reference input and voltage output range when used with an external op amp.

Serial I/O

The LTC1590 has a 3-wire SPI/MICROWIRE™ compatible serial port that accepts 24-bit serial words. Data is loaded MSB first with the first 12 bits controlling DAC A and the second 12 bits controlling DAC B. Data is shifted into the D_{IN} input on the rising edge of CLK. The $\overline{CS/LD}$ input must be taken low before transferring data to enable the CLK input. After transferring data, $\overline{CS/LD}$ is pulled high to load data from the shift register to the DAC registers which updates both DACs.

The buffered output of the 24-bit shift register is available on the D_{OUT} pin. Multiple DACs can be daisy-chained on one 3-wire interface by connecting the D_{OUT} pin to the D_{IN} pin of the next DAC (see the Timing Diagrams section).

Equivalent Circuit

Figure 1 shows an equivalent analog circuit for the LTC1590 DACs. R is the reference input, R_{REF} , which is nominally 11k. The DAC output is represented by the Thevinin equivalent current source with a value of:

$$(\text{Code}/4096)(V_{REF}/R)$$

The current source I_{LKG} models the junction leakage of the DAC output switches. I_{LKG} is typically less than 5nA at 85°C and decreases by roughly two times for every 10°C reduction in temperature. C_{OUT} is the output capacitance, and it also comes from the DAC output switches and varies from 30pF at zero scale to 60pF at full scale. R_O is the equivalent output resistance, which varies with digital input code (see Op Amp Selection section).

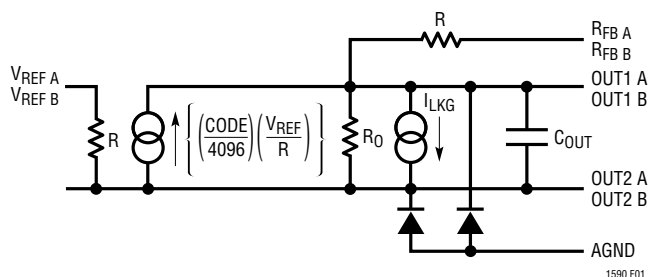

Figure 1. Equivalent Circuit

MICROWIRE is a trademark of National Semiconductor Corporation.

APPLICATIONS INFORMATION

Unipolar 2-Quadrant Multiplying Mode ($V_{OUT} = 0V$ to $-V_{REF}$)

The LTC1590 can be used with a dual op amp to provide a dual 2-quadrant multiplying DAC as shown in Figure 2. The unipolar DAC transfer function is shown in Table 1. The 33pF feedback capacitor is recommended to compensate for the pole caused by the internal feedback resistor and the OUT1 output capacitance. For high speed op amps this feedback capacitor is required for stability, and a smaller value, 8pF to 15pF, may be desired to get the fastest transient response and shortest settling time. A larger feedback capacitor can be used to reduce wideband noise, glitch impulse and distortion for lower frequency signals. A pole is introduced in the DAC transfer function at approximately $(C_{FB})(R_{FB})$. For example, a 100pF feedback capacitor will typically give a pole at:

$$145\text{kHz} = \frac{1}{2\pi(100\text{pF})(11\text{k}\Omega)}$$

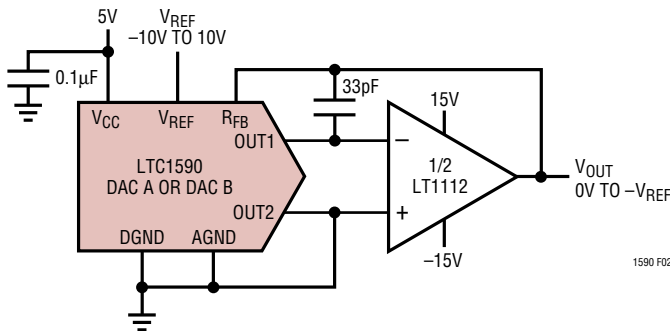

Figure 2. Unipolar Operation (2-Quadrant Multiplication)

Table 1. Unipolar Binary Code Table

| DIGITAL INPUT BINARY NUMBER IN DAC REGISTER | | ANALOG OUTPUT V_{OUT} |
|---|------|---------------------------------------|
| MSB | LSB | |
| 1111 | 1111 | $-V_{REF}$ (4095/4096) |
| 1000 | 0000 | $-V_{REF}$ (2048/4096) = $-V_{REF}/2$ |
| 0000 | 0000 | $-V_{REF}$ (1/4096) |
| 0000 | 0000 | 0V |

Bipolar 4-Quadrant Multiplying Mode ($V_{OUT} = -V_{REF}$ to $+V_{REF}$)

The circuit of Figure 3 can be used to provide a dual 4-quadrant multiplying DAC. This circuit starts with the unipolar application circuit and adds three resistors and an op amp. These extra devices provide a gain of -2 from the unipolar output to the bipolar output, plus an offset of $(-1)(V_{REF})$ to produce the transfer function shown in Table 2. A pack of matched 20k resistors, with two resistors in parallel forming the 10k resistor, is recommended.

Table 2. Bipolar Offset Binary Code Table

| DIGITAL INPUT BINARY NUMBER IN DAC REGISTER | | ANALOG OUTPUT V_{OUT} |
|---|------|-------------------------------------|
| MSB | LSB | |
| 1111 | 1111 | $+V_{REF}$ (2047/2048) |
| 1000 | 0000 | $+V_{REF}$ (1/2048) |
| 1000 | 0000 | 0V |
| 0111 | 1111 | $-V_{REF}$ (1/2048) |
| 0000 | 0000 | $-V_{REF}$ (2048/2048) = $-V_{REF}$ |

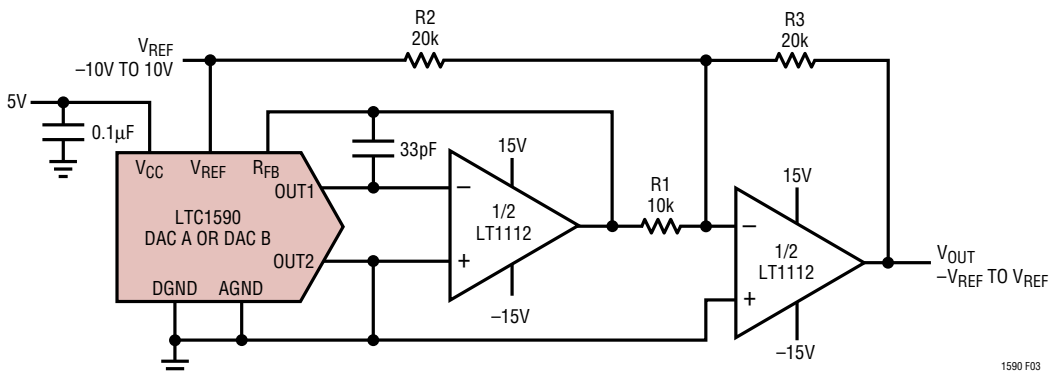

Figure 3. Bipolar Operation (4-Quadrant Multiplication)

APPLICATIONS INFORMATION

Op Amp Selection

To maintain the excellent accuracy and stability of the LTC1590 thought should be given to op amp selection. Fortunately, the sensitivity of INL and DNL to op amp offset has been significantly reduced compared to competing parts of this type. The op amp's V_{OS} causes DAC output offset. In addition, because the DAC's equivalent output resistance R_O changes as a function of code, there is a code-dependent DAC output error proportional to V_{OS} . For fixed reference applications this causes gain, INL and DNL error. For multiplying applications, a code-dependent, DC output voltage error is seen. At zero scale the DAC output error is equal to the op amp offset, and at full scale the output error is equal to twice the op amp offset. For example, a 1mV op amp offset will cause a 0.41LSB zero-scale error and a 0.82LSB full-scale error with a 10V full-scale range. The offset caused INL error is approximately 0.4 times the op amp V_{OS} and DNL error is 0.07 times op amp V_{OS} . For the same example of 1mV op amp V_{OS} and 10V full-scale range, the INL degradation will be 0.17LSB and DNL degradation will be 0.03LSB.

Op amp bias current causes only an offset error equal to $(I_{BIAS})(R_{FB}) \approx (I_{BIAS})(11k\Omega)$. For example, a 100nA op

amp bias current causes a 1.1mV DAC offset, or 0.45LSB for a 10V full-scale range. It is important to note that connecting the op amp noninverting input to ground through a resistor will not cancel bias current errors and should never be done! Similarly an offset caused by op amp bias current should not be adjusted by using the op amp null pins since this increases offset between DAC OUT1 and OUT2 pins, causing INL, DNL and gain errors. If op amp offset error adjustment is required, the op amp input offset voltage (the voltage difference between OUT1 and OUT2) should be nulled.

Grounding

As with any high precision data converter, clean grounding is important. A low impedance analog ground plane and star grounding should be used. OUT2 carries the complementary DAC output current and should be tied to the star ground with as low a resistance as possible. Other ground points that must be tied to the star ground point include the V_{REF} input ground, the op amp noninverting input(s) and the V_{OUT} ground reference point.

TYPICAL APPLICATIONS

Dual Programmable Attenuator

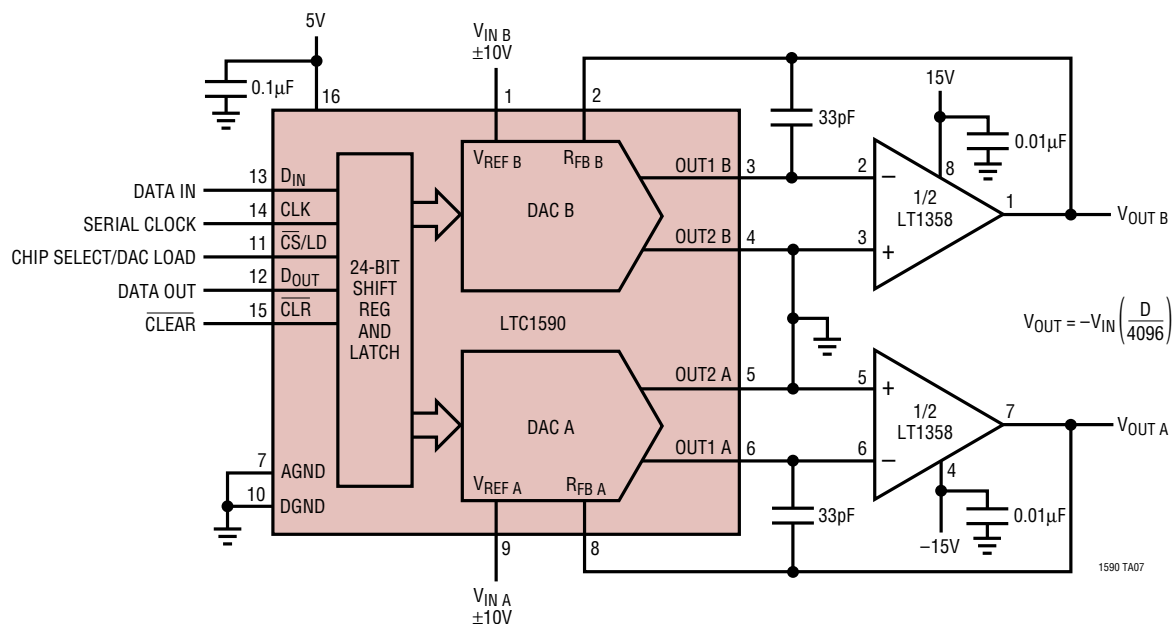

TYPICAL APPLICATIONS

Very Low Power Single Supply Dual V_{OUT} DAC

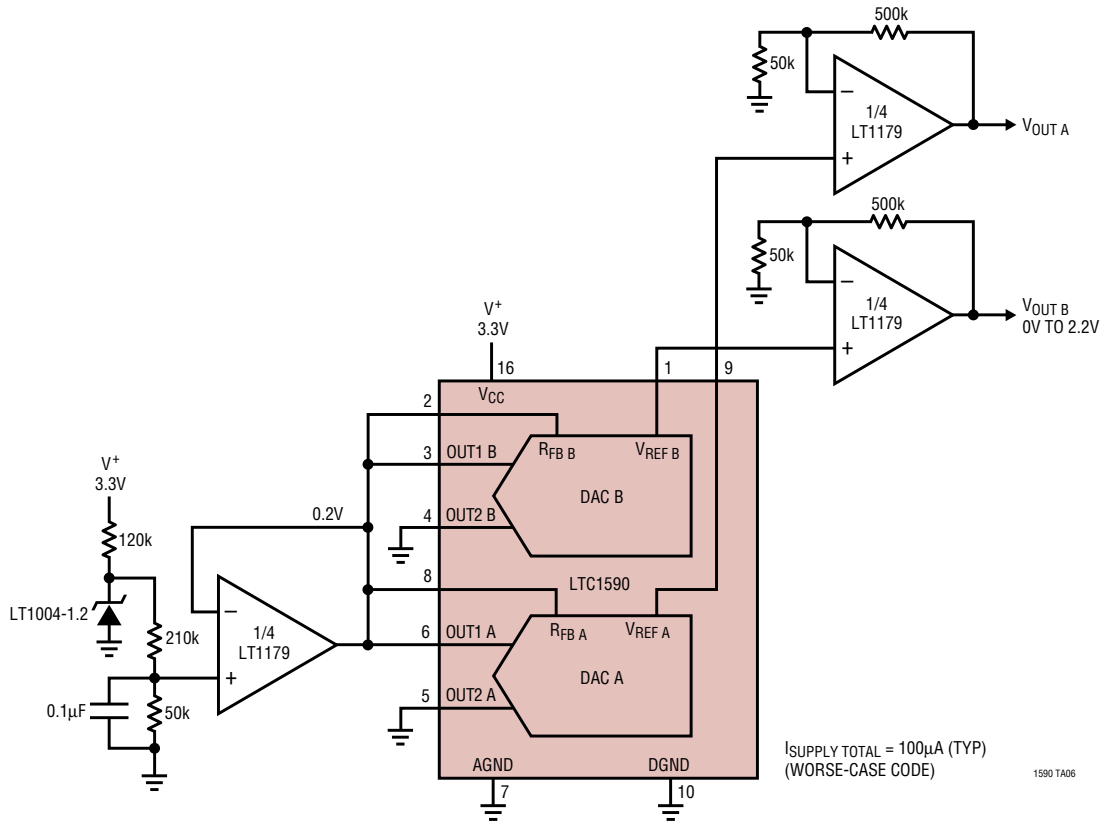

Dual Programmable Gain Amplifier

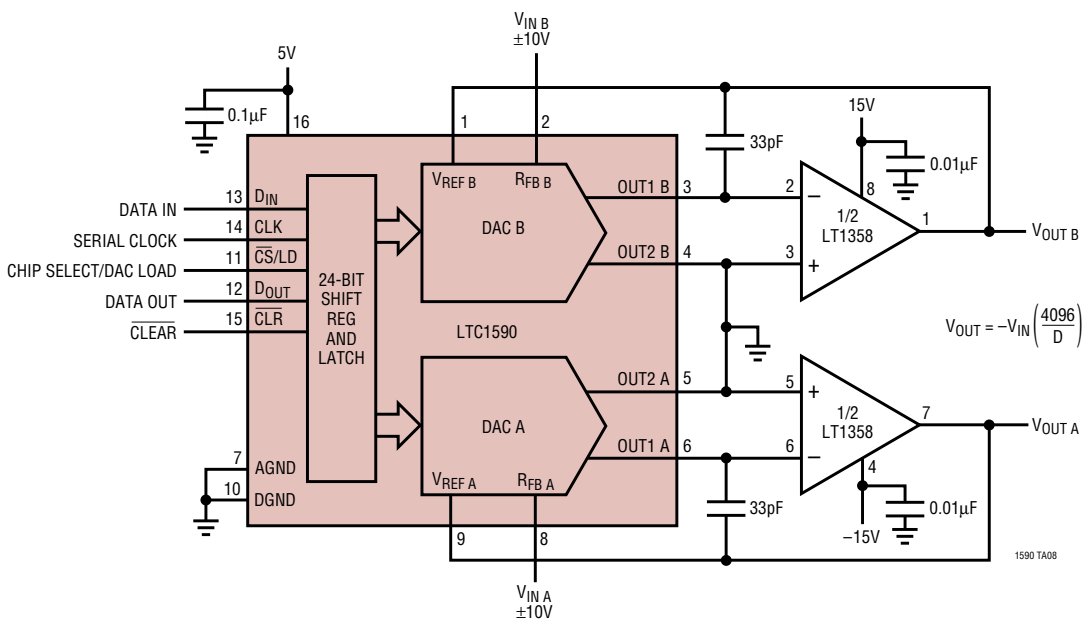

TYPICAL APPLICATIONS

Dual Programmable Gain Amplifier with Input Attenuation

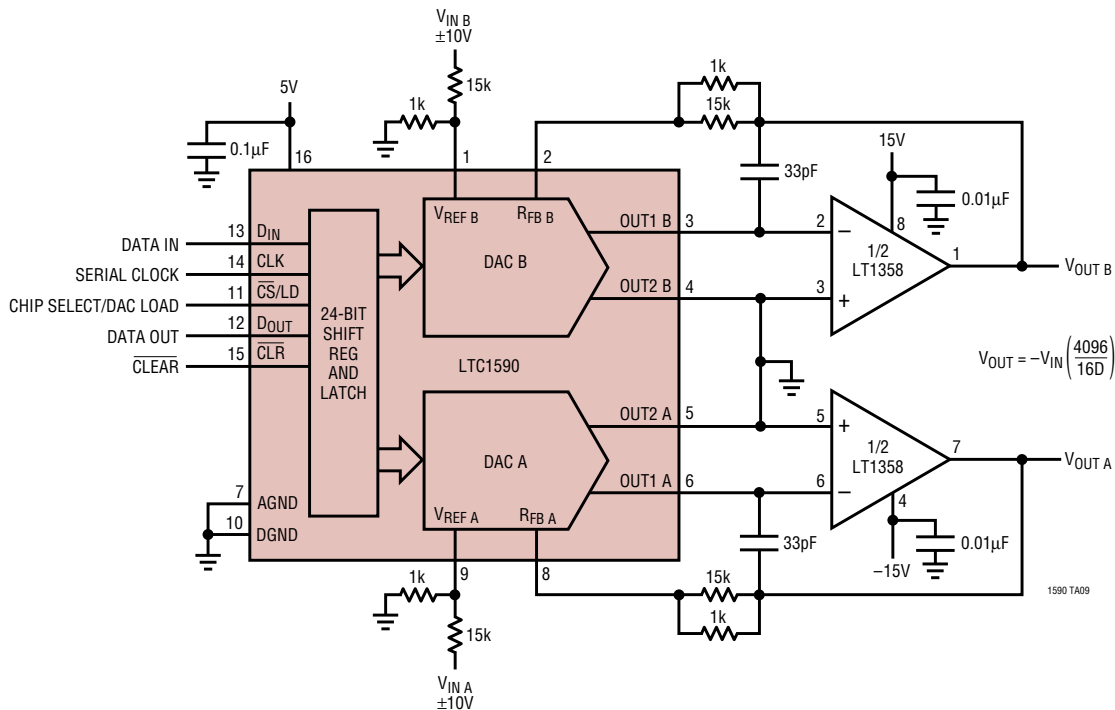

PACKAGE DESCRIPTION

Dimensions in inches (millimeters) unless otherwise noted.

N Package
16-Lead PDIP (Narrow 0.300)
 (LTC DWG # 05-08-1510)

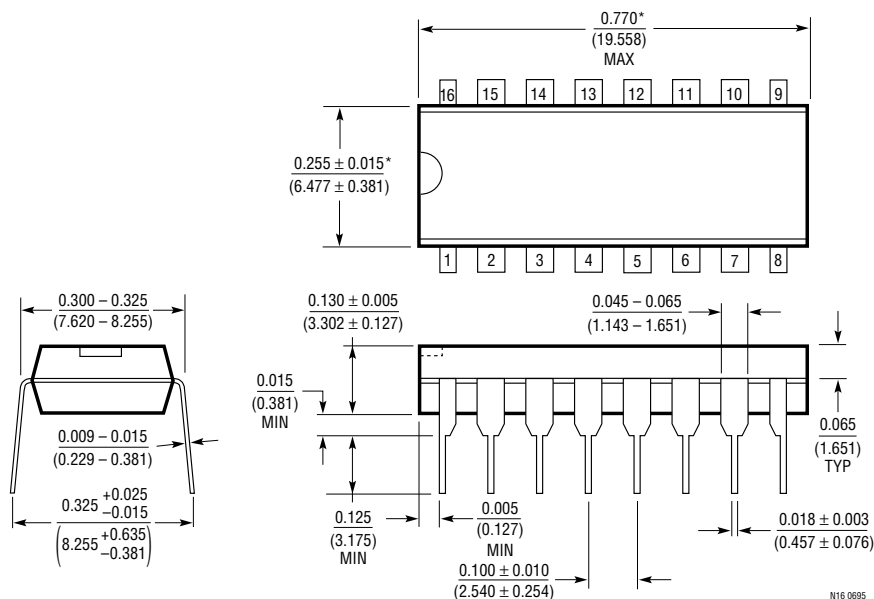

*THESE DIMENSIONS DO NOT INCLUDE MOLD FLASH OR PROTRUSIONS.
 MOLD FLASH OR PROTRUSIONS SHALL NOT EXCEED 0.010 INCH (0.254mm)

PACKAGE DESCRIPTION Dimensions in inches (millimeters) unless otherwise noted.

S Package 16-Lead Plastic Small Outline (Narrow 0.150) (LTC DWG # 05-08-1610)

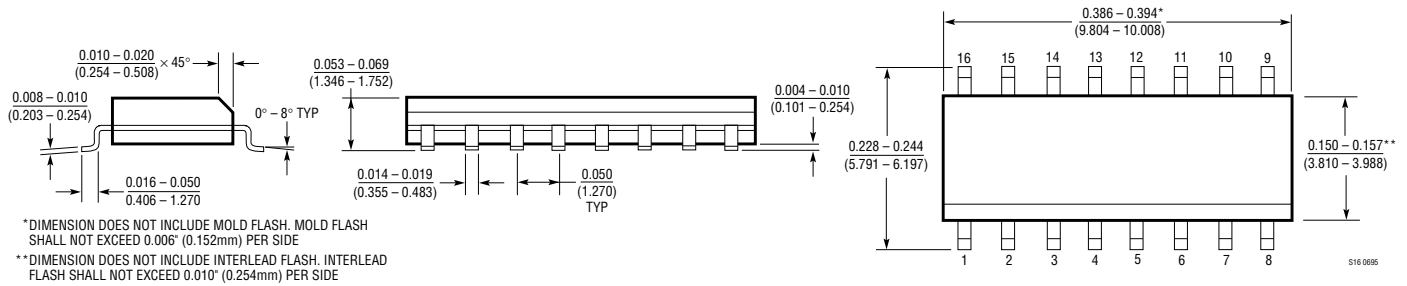

TYPICAL APPLICATION

Dual Programmable Attenuator with Gain

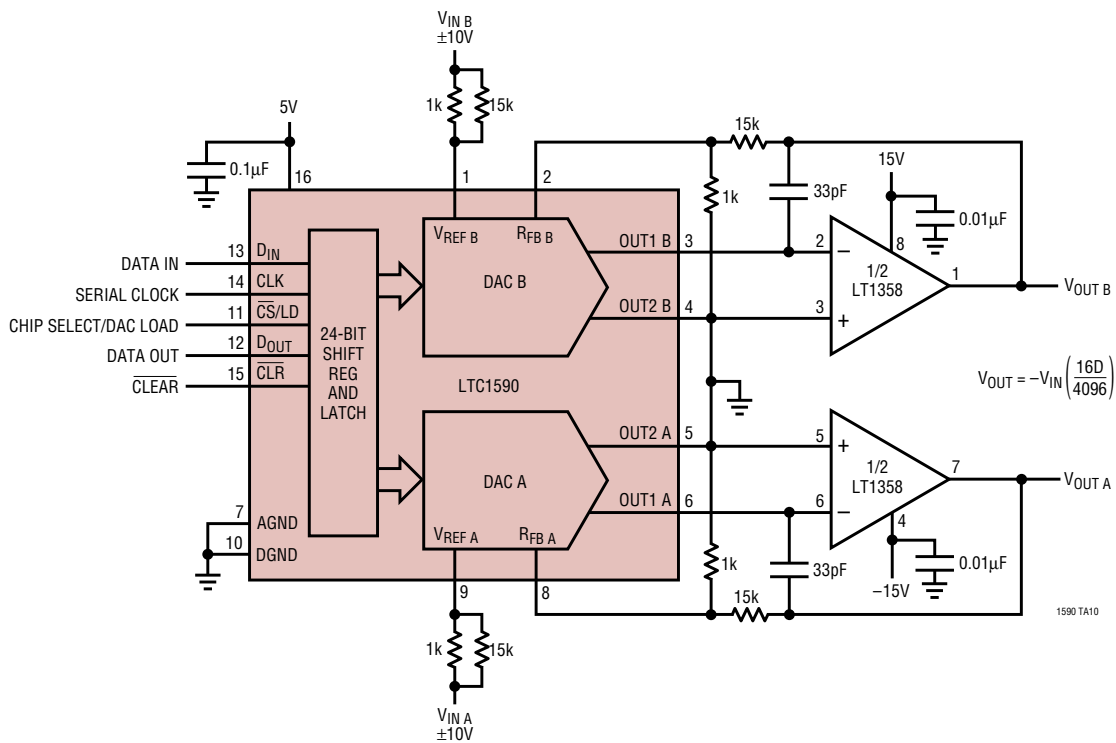

RELATED PARTS

| PART NUMBER | DESCRIPTION | COMMENTS |
|-----------------|--|--|
| LTC1595 | 16-Bit Multiplying I _{OUT} DAC in SO-8 | True 16-Bit Upgrade for DAC8043 |
| LTC1596 | 16-Bit Multiplying I _{OUT} DAC | True 16-Bit Upgrade for DAC8143 and AD7543 |
| LTC7541A | Parallel I/O Multiplying I _{OUT} 12-Bit DAC | 12-Bit Wide Parallel Input |
| LTC7543/LTC8143 | Serial I/O Multiplying I _{OUT} 12-Bit DACs | Clear Pin and Serial Data Output (LTC8143) |
| LTC7545A | Parallel I/O Multiplying I _{OUT} 12-Bit DAC | 12-Bit Wide Latched Parallel Input |
| LTC8043 | Serial I/O Multiplying I _{OUT} 12-Bit DAC | 8-Pin SO and PDIP |