

**FEATURES**

**Differential analog inputs**  
**CDS or SHA (CDS bypass) with 7 gain settings**  
**0 dB to 36 dB, 10-bit variable gain amplifier (VGA)**  
**16-bit, 75 MSPS analog-to-digital converter (ADC)**  
***Precision Timing* core with 210 ps resolution at 75 MHz**  
**8 independent H-clock phases with programmable drive strength (3.6 V maximum swing)**  
**4 general-purpose outputs (GPO)**  
**On-chip sync generator with external sync input**  
**Reduced range LVDS outputs with single clock lane**  
**6 mm × 6 mm CSP\_BGA package with 0.5 mm pitch**

**APPLICATIONS**

**Industrial cameras**  
**Surveillance cameras**  
**Medical imaging**  
**Professional photography**

**GENERAL DESCRIPTION**

The **ADDI7013** is a highly integrated, dual-channel, CCD signal processor for high speed digital imaging applications. Each channel is specified at pixel rates of up to 75 MHz and consists of a complete analog front end (AFE) with analog-to-digital conversion. The *Precision Timing*® core allows adjustment of the correlated double sampler (CDS) and horizontal clocks with 210 ps resolution at 75 MHz operation. There are eight independent horizontal clock outputs with programmable drive strength to support a variety of CCD timing requirements.

Each analog front end includes black level clamping; a CDS; a VGA; and a 16-bit, 75 MSPS analog-to-digital converter (ADC). Operation is programmed using a 3-wire serial interface.

Packaged in a space-saving, 6 mm × 6 mm, CSP\_BGA, the **ADDI7013** is specified over an operating temperature range of -40°C to +85°C.

**FUNCTIONAL BLOCK DIAGRAM**

Figure 1.

11784-001

For more information about the **ADDI7013**, contact Analog Devices, Inc., at [afe.ccd@analog.com](mailto:afe.ccd@analog.com).

Rev. Sp0

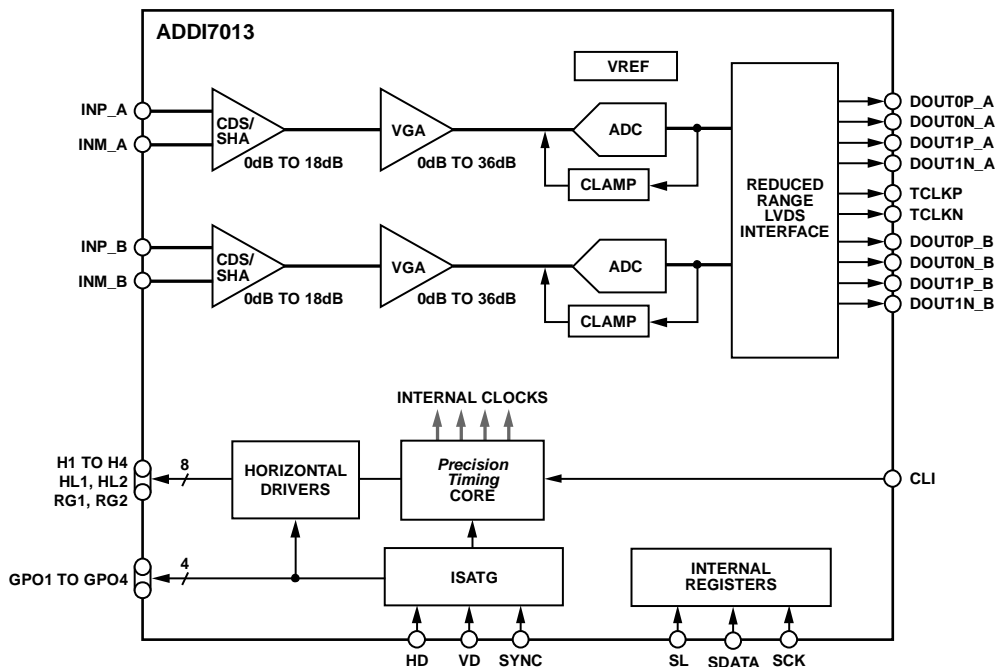
Document Feedback

Information furnished by Analog Devices is believed to be accurate and reliable. However, no responsibility is assumed by Analog Devices for its use, nor for any infringements of patents or other rights of third parties that may result from its use. Specifications subject to change without notice. No license is granted by implication or otherwise under any patent or patent rights of Analog Devices. Trademarks and registered trademarks are the property of their respective owners.

One Technology Way, P.O. Box 9106, Norwood, MA 02062-9106, U.S.A.  
 Tel: 781.329.4700 ©2013 Analog Devices, Inc. All rights reserved.  
 Technical Support [www.analog.com](http://www.analog.com)

**NOTES**