

DESCRIPTION

Demonstration circuit 1171A is a single output synchronous buck converter featuring the LTC3851EGN. The circuit is designed with all components on the top side. The package style for the LTC3851EGN is a 16-lead narrow SSOP.

Two versions of the board are available. DC-1171A-A has an on-board sense resistor for current feedback, while the DC1171A-B is configured with a DCR sense circuit that allows the converter to use the inductor's DCR as the sense element instead of the on-board sense resistor to save cost, board space while improving full load efficiency over 2%.

The main features of the board include an internal 5V linear regulator for bias and a Mode selector that allows the converter to run in CCM, pulse skip or Burst Mode operation (requires some minor modification). Synchronization to an external clock is also possible.

The input voltage range is 4.5V to 14V. The LTC3851 datasheet gives a complete description of the part, operation and application information and must be read in conjunction with this quick start guide for demo circuit 1171A.

Design files for this circuit board are available. Call the LTC factory.

Burst Mode is a trademark of Linear Technology Corporation

Table 1. Performance Summary ($T_A = 25^\circ\text{C}$)

PARAMETER	CONDITION	VALUE
Input Voltage Range		4.5V - 14V
Output Voltage V_{OUT}	$V_{IN} = 4.5\text{V to }14\text{V}$, $I_{OUT} = 0\text{A to }15\text{A}$	$1.5\text{V} \pm 2\%$
Nominal Switching Frequency		400kHz
Efficiency	$V_{OUT} = 1.5\text{V}$, $I_{OUT1} = 15\text{A}$; $V_{IN} = 12\text{V}$	87.3% Typical (A-A)
See Figure 3 and 4 for efficiency curves		90.0% Typical (A-B)

QUICK START PROCEDURE

Demonstration circuit 1171A is easy to set up to evaluate the performance of the LTC3851EGN. Refer to Figure 1 for proper measurement equipment setup and follow the procedure below:

NOTE: When measuring the input or output voltage ripple, care must be taken to avoid a long ground lead on the oscilloscope probe. Measure the input or output voltage ripple by touching the probe tip directly across the V_{in} or V_{out} and GND terminals. See Figure 2 for proper scope probe technique.

- Place jumpers in the following positions:

JP1	400k
JP2	On
JP3	CCM

- With power off, connect the input power supply to V_{in} and GND.
- Turn on the power at the input.

NOTE: Make sure that the input voltage does not exceed 14V.

QUICK START GUIDE FOR DEMONSTRATION CIRCUIT 1171A SYNCHRONOUS BUCK CONVERTER

4. Check for the proper output voltage.

$V_{out} = 1.470V$ to $1.530V$

NOTE: If there is no output, temporarily disconnect the load to make sure that the load is not set too high.

5. Once the proper output voltages are established, adjust the loads within the operating

range and observe the output voltage regulation, ripple voltage, efficiency and other parameters.

6. Different operating modes can be evaluated by changing the position of jumper JP3 and are discussed in the next section.

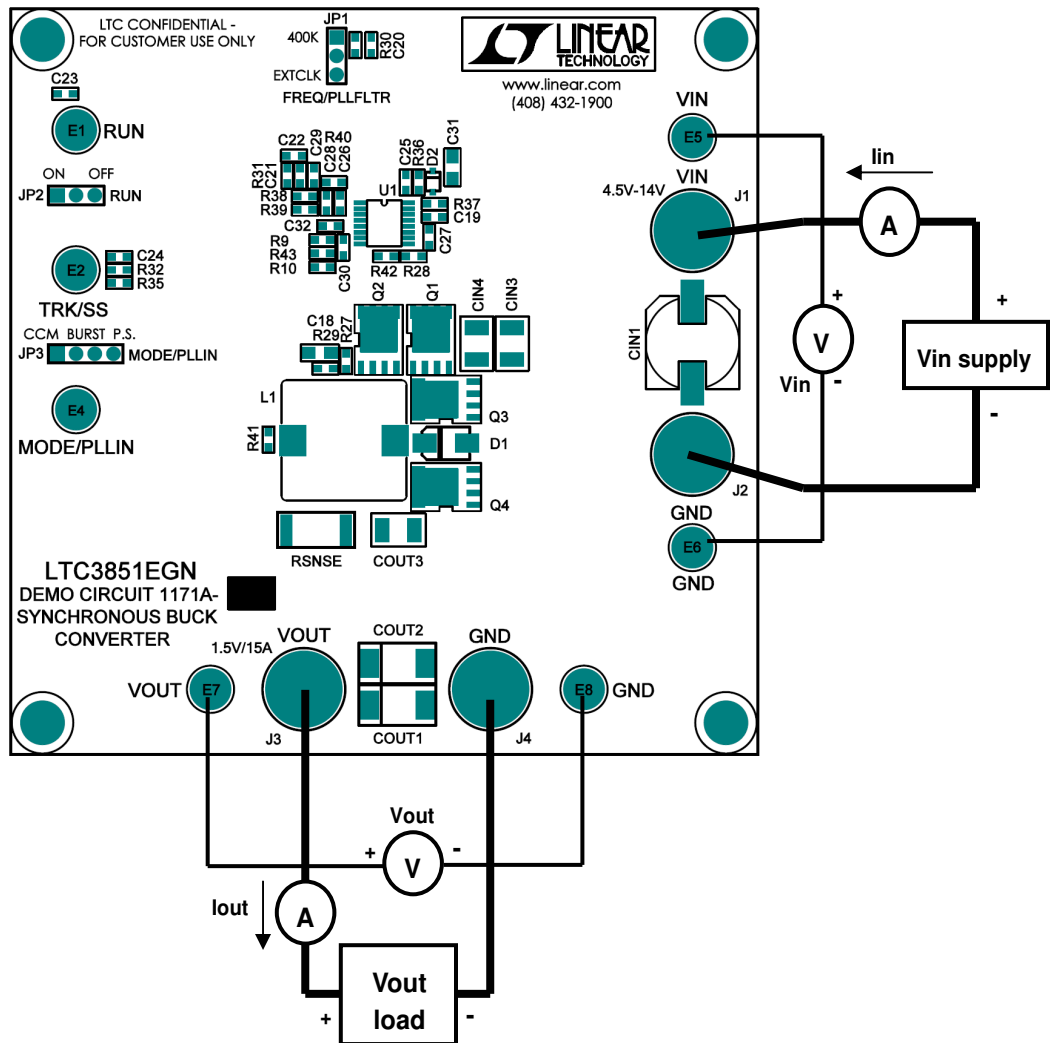

Figure 1. Proper Measurement Equipment Setup

QUICK START GUIDE FOR DEMONSTRATION CIRCUIT 1171A

SYNCHRONOUS BUCK CONVERTER

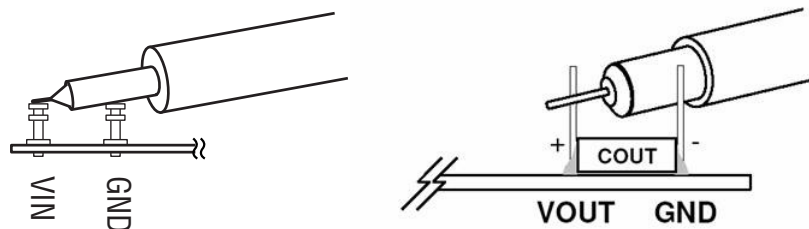

Figure 2. Measuring Input or Output Ripple Across Terminals or Directly Across Bulk Capacitor

FREQUENCY SYNCHRONIZATION AND MODE SELECTION

Demonstration circuit 1171A's Mode selector allows the converter to run in CCM or pulse skip operation by changing position of jumper JP3. For synchronizing to an external clock source

both JP1 and JP3 needs to be adjusted, while for Burst Mode operation some bench modification is needed. Refer to Table 2 and to the data sheet for more details.

Table 2. Mode Selection and Synchronized Operation Options

CONFIGURATION	BOARD MODIFICATION	MODE SELECTOR	
		JP1	JP4
CCM operation	-	'400K'	'CCM'
Pulse skip operation	-	'400K'	'P.S.'
Burst Mode operation	100k resistor between JP4 pin1 and pin2	'400K'	Remove Jumper
Synchronized to ext. clock applied to MODE/PLLIN pin	-	'EXTCLK'	'BURST'

RAIL TRACKING

Demonstration circuit 1171A is configured for an on board soft start circuit. The soft start ramp rate can be adjusted by changing the value of C24. Demonstration circuit 1171A can also be

modified to track an external reference. Refer to Table 3 for tracking options and to the data sheet for more details.

Table 3. Output Tracking Options

CONFIGURATION	TRK/SS RESISTORS AND CAPACITOR			RAIL TRACKING
	R32	R35	C24	TRK/SS PIN
Soft Start Without Tracking (Default)	0 Ω	Open	0.1 μ F	Open
Vout equals External Ramp	0 Ω	Open	Open	External reference applied
Vout tracking scaled external ramp	Resistor divider		Open	External reference applied

QUICK START GUIDE FOR DEMONSTRATION CIRCUIT 1171A

SYNCHRONOUS BUCK CONVERTER

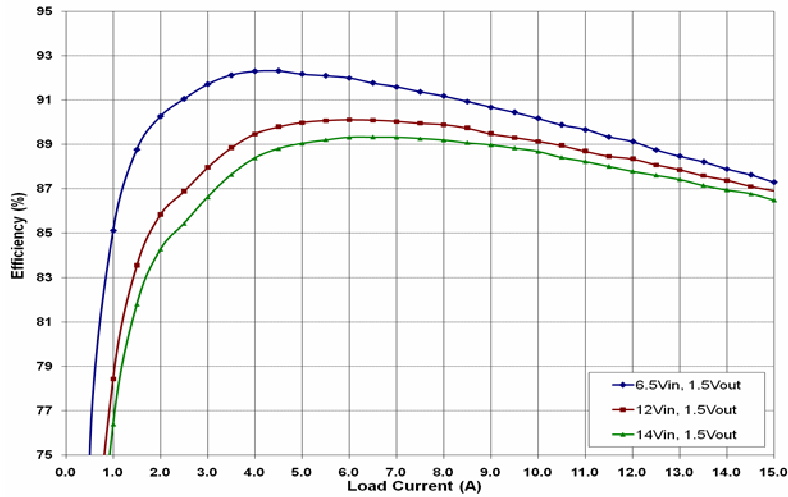

Figure 3. Typical Efficiency vs. Load Current for DC1171A-A

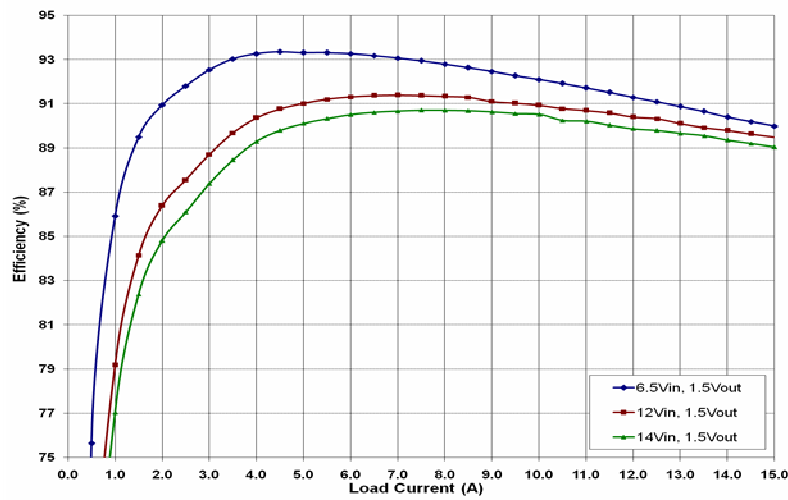

Figure 4. Typical Efficiency vs. Load Current for DC1171A-B

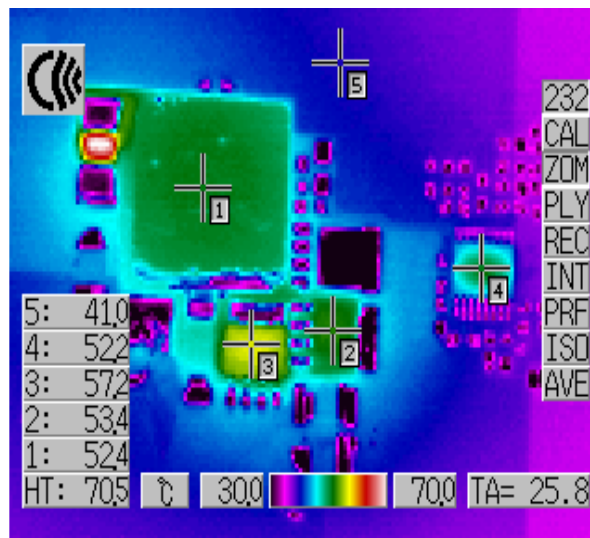

Figure 5. Thermal image of DC1171A-A, 14Vin, 1.5V@15Aout

This circuit is proprietary to Linear Technology and supplied for use with Linear Technology parts.
Customer Notice: Linear Technology has made a best effort to design a circuit that meets customer-supplied specifications; however, it remains the customer's responsibility to verify proper and reliable operation in the actual application. Component substitution and printed circuit board layout may significantly affect circuit performance or reliability. Contact Linear Applications Engineering for assistance.

