

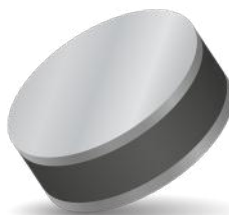

NTC Thermistors Products

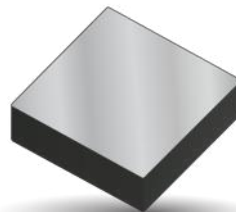
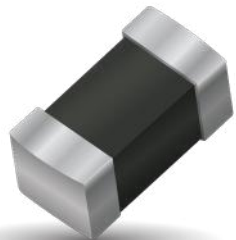
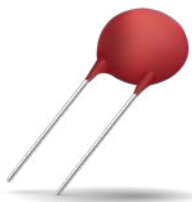

IMPORTANT INFORMATION/DISCLAIMER

All product specifications, statements, information and data (collectively, the “Information”) in this datasheet or made available on the website are subject to change. The customer is responsible for checking and verifying the extent to which the Information contained in this publication is applicable to an order at the time the order is placed. All Information given herein is believed to be accurate and reliable, but it is presented without guarantee, warranty, or responsibility of any kind, expressed or implied.

Statements of suitability for certain applications are based on AVX’s knowledge of typical operating conditions for such applications, but are not intended to constitute and AVX specifically disclaims any warranty concerning suitability for a specific customer application or use.

ANY USE OF PRODUCT OUTSIDE OF SPECIFICATIONS OR ANY STORAGE OR INSTALLATION INCONSISTENT WITH PRODUCT GUIDANCE VOIDS ANY WARRANTY.

The Information is intended for use only by customers who have the requisite experience and capability to determine the correct products for their application. Any technical advice inferred from this Information or otherwise provided by AVX with reference to the use of AVX’s products is given without regard, and AVX assumes no obligation or liability for the advice given or results obtained.

Although AVX designs and manufactures its products to the most stringent quality and safety standards, given the current state of the art, isolated component failures may still occur. Accordingly, customer applications which require a high degree of reliability or safety should employ suitable designs or other safeguards (such as installation of protective circuitry or redundancies) in order to ensure that the failure of an electrical component does not result in a risk of personal injury or property damage.

Unless specifically agreed to in writing, AVX has not tested or certified its products, services or deliverables for use in high risk applications including medical life support, medical device, direct physical patient contact, water treatment, nuclear facilities, weapon systems, mass and air transportation control, flammable environments, or any other potentially life critical uses. Customer understands and agrees that AVX makes no assurances that the products, services or deliverables are suitable for any high-risk uses. Under no circumstances does AVX warrant or guarantee suitability for any customer design or manufacturing process.

Although all product-related warnings, cautions and notes must be observed, the customer should not assume that all safety measures are indicated or that other measures may not be required.

NTC THERMISTORS



Table of Contents

NTC THERMISTORS

Selection Guide	1
Ordering Code	2
General Characteristics.....	3
Application Notes.....	7

NTC SMD THERMISTORS

NB 21 (Ni Barrier/100% Sn Termination).....	9
NB 12 - NB 20 (Ni Barrier/100% Sn Termination).....	11
NC 21 (AgPdPt Termination).....	13
NC 12 – NC 20 (PdPtAg Termination).....	15
Packaging.....	17
Surface Mounting Guide.....	19

NTC ACCURATE THERMISTORS

NP30 - NJ 28 – NI 24 – NK 20	20
------------------------------------	----

NTC DISC THERMISTORS

ND 03/06/09 – NE 03/06/09 – NV 06/09	24
Packaging for Automatic Insertion.....	28

NTC LEADLESS DISC THERMISTORS..... 30

RESISTANCE

Tables of Resistance vs Temperature.....	32
--	----

IDENTIFICATION – TRACEABILITY 37

As we are anxious that our customers should benefit from the latest developments in the technology and standards, AVX reserves the right to modify the characteristics published in this brochure.

NOTICE: Specifications are subject to change without notice. Contact your nearest AVX Sales Office for the latest specifications. All statements, information and data given herein are believed to be accurate and reliable, but are presented without guarantee, warranty, or responsibility of any kind, expressed or implied. Statements or suggestions concerning possible use of our products are made without representation or warranty that any such use is free of patent infringement and are not recommendations to infringe any patent. The user should not assume that all safety measures are indicated or that other measures may not be required. Specifications are typical and may not apply to all applications.



The Important Information/Disclaimer is incorporated in these specifications by reference and should be reviewed in full before placing any order.

NTC THERMISTORS

Selection Guide



SMD – NI BARRIER/100% SN TERMINATION (FOR LEAD FREE SOLDERING)

Series	Fig.	Size	Range	Op. Temp	Applications	Page
NB21		0603	Res: 47Ω - 470kΩ Tol: 3%*, 5%, 10%, 20%	-55 to +150°C	<ul style="list-style-type: none"> • Temperature Compensation • Temperature Measurement • Commercial, Industrial, Automotive • AEC-Q 200 Qualified 	10
NB12		0805	Res: 18Ω - 1MΩ Tol: 3%*, 5%, 10%, 20%	-55 to +150°C		12
NB20		1206	Res: 220Ω - 1MΩ Tol: 3%*, 5%, 10%, 20%	-55 to +150°C		12

SMD – PDPTAG TERMINATION (FOR HYBRID ASSEMBLY)

Series	Fig.	Size	Range	Op. Temp	Applications	Page
NC12		0805	Res: 18Ω - 220kΩ Tol: 3%*, 5%, 10%, 20%	-55 to +150°C	<ul style="list-style-type: none"> • Temperature Compensation • Temperature Measurement • Commercial, Industrial, Automotive • AEC-Q 200 Qualified 	14
NC20		1206	Res: 10Ω - 1MΩ Tol: 3%*, 5%, 10%, 20%	-55 to +150°C		14

HIGH ACCURACY SERIES

Series	Fig.	Size	Range	Op. Temp	Applications	Page
NP30		3.0 mm	Res: 2kΩ - 100kΩ Tol: 1%, 2%, 3%	-55 to +150°C	<ul style="list-style-type: none"> • High Accuracy Temperature Measurement • Liquid level or flow detection • Commercial, Industrial, Automotive • AEC-Q 200 Qualified 	19
NJ28		2.8mm	Res: 2kΩ - 100kΩ Tol: 1%, 2%, 3%	-55 to +150°C		19
NI24		2.4mm	Res: 2kΩ - 100kΩ Tol: 1%, 2%, 3%	-55 to +150°C		19
NK20		Custom	Res: 2kΩ - 100kΩ Tol: 1%, 2%, 3%	-55 to +150°C		19

LEADED DISC

Series	Fig.	Size	Range	Op. Temp	Applications	Page
N.03		3.0 mm	Res: 680Ω - 1MΩ Tol: 3%*, 5%, 10%, 20%	-55 to +150°C	<ul style="list-style-type: none"> • Temperature Measurement • Temperature Compensation • Liquid level or flow detection • Commercial, Industrial, Automotive • AEC-Q 200 Qualified 	22
N.06		6.0 mm	Res: 150Ω - 330kΩ Tol: 3%*, 5%, 10%, 20%	-55 to +150°C		22
N.09		9.0mm	Res: 68Ω - 150kΩ Tol: 3%*, 5%, 10%, 20%	-55 to +150°C		22

LEADLESS DISC

Series	Fig.	Size	Range	Op. Temp	Applications	Page
NR		Custom	Custom designed products generally defined at two temperatures	-40 to +200°C	<ul style="list-style-type: none"> • Thermal control in automotive and industrial applications • AEC-Q 200 Qualified 	28



The Important Information/Disclaimer is incorporated in these specifications by reference and should be reviewed in full before placing any order.

NTC THERMISTORS

Ordering Code



HOW TO ORDER

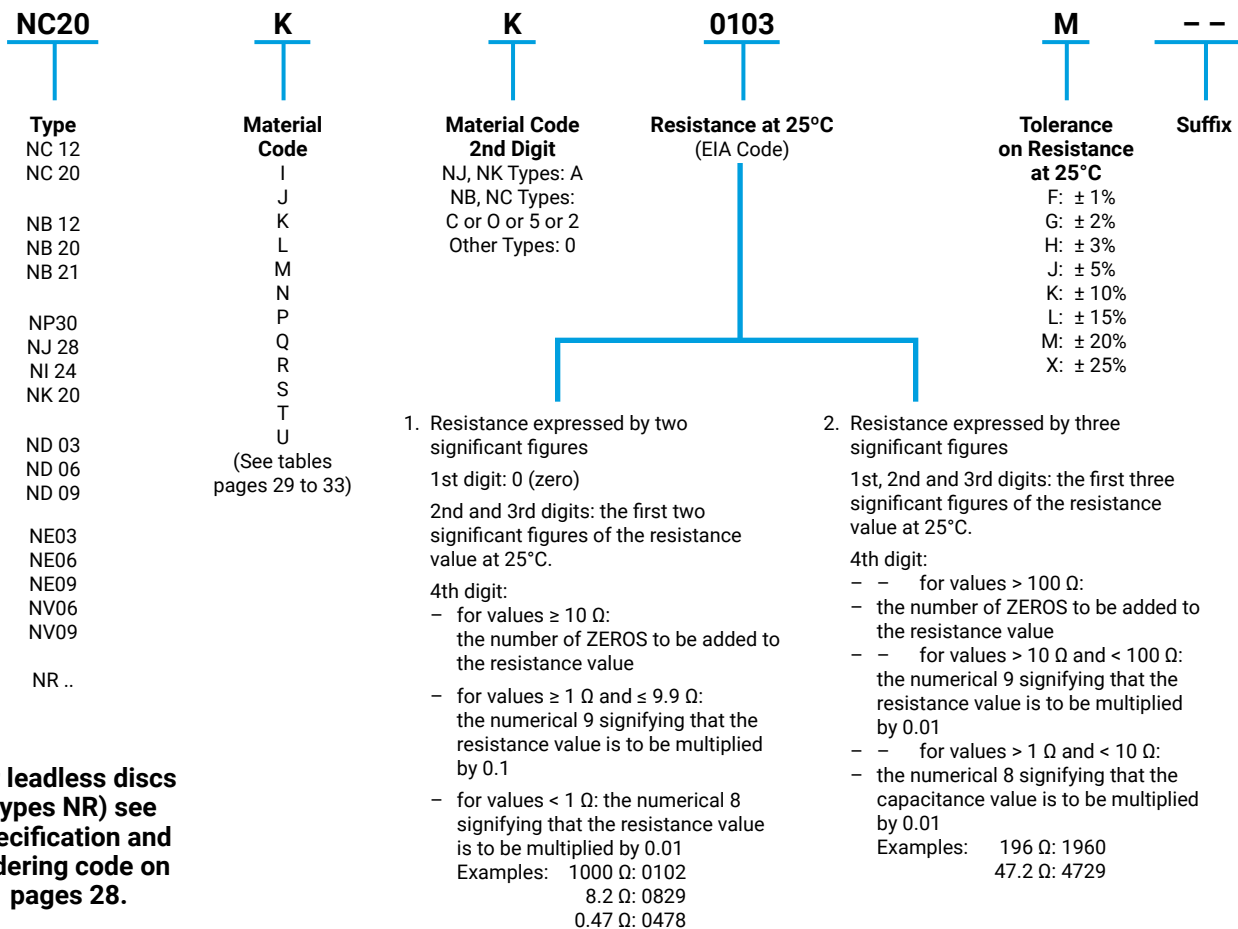

For leadless discs (types NR) see specification and ordering code on pages 28.



ROHS/ELV COMPLIANCE BY PRODUCT FAMILY

RoHS (Restriction of Hazardous Substances - European Union directive 2002/95/EC).
 RoHS2 (Restriction of Hazardous Substances - European Union directive 2011/65/EC)
 ELV (End of Life-Vehicle - European Union directive 2000/53/EC).
 All Thermistor Products have been fully RoHS/ELV since before 2006.
 Chip Thermistor NB RoHS/ELV Status: external Plating 100% smooth semi-bright Sn as standard SnPb Termination available on request.

Products that are supplied AS STANDARD in RoHS/ELV compliant form for listed

Industrial Product Family		RoHS Compliant for Material Listed					
Group	Series	Cadmium	Hexavalent Chromium	Lead	Mercury	PBBs	PBDEs
Leaded NTC Thermistors	Thermistors NF NI	✓	✓	✓	✓	✓	✓
	Thermistors ND NJ NP	✓	✓	✓	✓	✓	✓
SMD Thermistors	Thermistors NC	✓	✓	✓	✓	✓	✓
	Thermistors NB	✓	✓	✓	✓	✓	✓

NTC THERMISTORS



General Characteristics

1 – INTRODUCTION

NTC thermistors are thermally sensitive resistors made from a mixture of Mn, Ni, Co, Cu, Fe oxides. Sintered ceramic bodies of various sizes can be obtained. Strict conditions of mixing, pressing, sintering and metallization ensure an excellent batch-to-batch product characteristics.

This semi-conducting material reacts as an NTC resistor, whose resistance decreases with increasing temperature. This Negative Temperature Coefficient effect can result from an external change of the ambient temperature or an internal heating due to the Joule effect of a current flowing through the thermistor.

By varying the composition and the size of the thermistors, a wide range of resistance values (0.1Ω to 1MΩ) and temperature coefficients (-2 to -6% per °C) can be achieved.

RoHS (Restriction of Hazardous Substances - European Union directive 2002/95/EC).

ELV (End of Life-Vehicle - European Union directive 2000/53/EC).

All Thermistor Products have been fully RoHS/ELV since before 2006.

Chip Thermistor NB RoHS/ELV Status: external Plating 100% smooth semi-bright Sn as standard SnPb Termination available on request.

2 – MAIN CHARACTERISTICS

2.1 CHARACTERISTICS WITH NO DISSIPATION

2.1.1. Nominal Resistance (Rn)

The nominal resistance of an NTC thermistor is generally given at 25°C. It has to be measured at near zero power so that the resultant heating only produces a negligible measurement error.

The following table gives the maximum advised measurement voltage as a function of resistance values and thermal dissipation factors.

This voltage is such that the heating effect generated by the measurement current only causes a resistance change of 1% Rn/Rn.

Ranges of values (Ω)	Maximum measuring voltage (V)			
	δ=2mW/°C	δ=5mW/°C	δ=10mW/°C	δ=20mW/°C
R 10				0.10
10 < R 100		0.13	0.18	0.24
100 < R 1,000	0.25	0.38	0.53	0.24
1,000 < R 10,000	0.73	1.1	1.5	2.0
10,000 < R 100,000	2.1	3.2	4.6	
R < 100,000	6.4	9.7	14.5	

2.1.2. Temperature - Resistance characteristics R (T)

This is the relation between the zero power resistance and the temperature. It can be determined by experimental measurements and may be described by the ratios R (T) / R (25°C) where:

R (T) is the resistance at any temperature T
R (25°C) is the resistance at 25°C.

These ratios are displayed on pages 29 to 33.

2.1.3. Temperature coefficient (α)

The temperature coefficient (α) which is the slope of the curve at a given point is defined by:

$$\alpha = \frac{100}{R} \cdot \frac{dR}{dT} \text{ and expressed in \% per } ^\circ\text{C}.$$

2.1.4. Sensitivity index (B)

The equation $R = A \exp (B/T)$ may be used as a rough approximation of the characteristic R (T).

B is called the sensitivity index or constant of the material used.

To calculate the B value, it is necessary to know the resistances R₁ and R₂ of the thermistor at the temperatures T₁ and T₂.

$$\text{The equation: } R_1 = R_2 \exp B \left(\frac{1}{T_1} - \frac{1}{T_2} \right)$$

$$\text{leads to: } B (K) = \frac{1}{\left(\frac{1}{T_1} - \frac{1}{T_2} \right)} \cdot \ln \left(\frac{R_1}{R_2} \right)$$

Conventionally, B will be most often calculated for temperatures T₁ = 25°C and T₂ = 85°C (298.16 K and 358.16 K).

In fact, as the equation $R = A \exp (B/T)$ is an approximation, the value of B depends on the temperatures T₁ and T₂ by which it is calculated.

For example, from the R (T) characteristic of material M (values given on page 29), it can be calculated:

$$\begin{aligned} B (25 - 85) &= 3950 \\ B (0 - 60) &= 3901 \\ B (50 - 110) &= 3983 \end{aligned}$$

When using the equation $R = A \exp (B/T)$ for this material, the error can vary by as much as 9% at 25°C, 0.6% at 55°C and 1.6% at 125°C.

Using the same equation, it is possible to relate the values of the index B and the coefficient α:

$$\alpha = \frac{1}{R} \cdot \frac{dR}{dT} = \frac{1}{A \exp (B/T)} \cdot A \exp (B/T) \cdot \frac{-B}{T^2}$$

$$\text{thus } \alpha = - \frac{B}{T^2} \text{ expressed in \% } ^\circ\text{C}$$



NTC THERMISTORS



General Characteristics

2.1.5. Further approximation of R (T) curve

The description of the characteristic R (T) can be improved by using a greater number of experimental points, and by using the equation:

$$\frac{1}{T} = A + B (\ln R) + C (\ln R)^3$$

The parameters A, B and C are determined by solving the set of equations obtained by using the measured resistances at three temperatures.

The solution of the above equation gives the resistance at any temperature:

$$\ln R(T) = \frac{1}{3} \left[\sqrt[3]{- \frac{27}{2} \left(\frac{A-1/T}{C} \right) + \frac{3}{2} \sqrt{3 \left(\sqrt{27 \left(\frac{A-1/T}{C} \right)^2 + 4 \left(\frac{B}{C} \right)^3} \right)}} \right. \\ \left. - \sqrt[3]{+ \frac{27}{2} \left(\frac{A-1/T}{C} \right) + \frac{3}{2} \sqrt{3 \left(\sqrt{27 \left(\frac{A-1/T}{C} \right)^2 + 4 \left(\frac{B}{C} \right)^3} \right)}} \right]$$

The precision of this description is typically 0.2°C for the range -50 to +150°C (A, B, C being determined with experimental values at -20, +50 and 120°C) or even better if this temperature range is reduced. The ratios R(T)/R(25°C) for each of the different materials shown on pages 29 to 33 have been calculated using the above method.

2.1.6. Resistance tolerance and temperature precision

An important characteristic of a thermistor is the tolerance on the resistance value at a given temperature.

This uncertainty on the resistance (DR/R) may be related to the corresponding uncertainty on the temperature (DT), using the relationship:

$$\Delta T = 100 \cdot \frac{\Delta R}{R} \cdot \frac{1}{\alpha}$$

Example: consider the thermistor ND06M00152J –

- R (25°C) = 1500 ohms
- Made from M material
- R (T) characteristic shown on page 23 gives: $\alpha = -4.4\%/^{\circ}\text{C}$ at 25°C
- Tolerance $\Delta R/R = \pm 5\%$ is equivalent to: $\Delta T = 5\%/4.4\%/^{\circ}\text{C} = \pm 1.14^{\circ}\text{C}$

2.1.7. Resistance tolerance at any temperature

Any material used for NTC manufacturing always displays a dispersion for the R (T) characteristic.

This dispersion depends on the type of material used and has been especially reduced for our accuracy series thermistors.

Thus, the tolerance on the resistance ($\Delta R_2/R_2$) at a temperature T_2 is the sum of two contributions as illustrated on Figure 1:

- the tolerance $\Delta R_1/R_1$ at a temperature T_1 used as a reference.
- an additional contribution due to the dispersion on the characteristic R (T) which may be called “Manufacturing tolerance” (Tf).

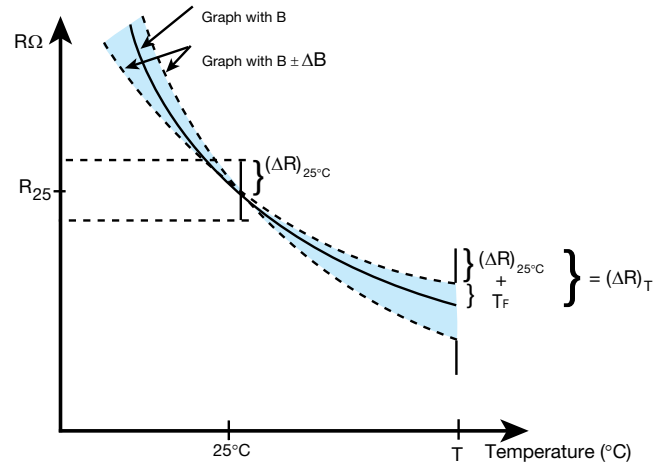

Figure 1

Differentiating the equation $R = A \exp (B/T)$, the two contributions on the tolerance at T can also be written:

$$\frac{\Delta R_2}{R_2} = \frac{\Delta R_1}{R_1} + \frac{1}{T_1} - \frac{1}{T_2} \cdot \Delta B$$

The T(f) values given with the resistance – temperature characteristics on pages 29 to 33 are based on a computer simulation using this equation and experimental values.

2.1.8. Designing the resistance tolerances

Using the fact that the coefficient decreases with temperature ($\alpha = -B/T^2$), it is generally useful to define the closest tolerance of the thermistor at the maximum value of the temperature range where an accuracy in °C is required.

For example, let us compare the two designs 1 and 2 hereafter:

T (°C)	R (Ω)	α (%/°C)	Design 1		Design 2	
			ΔR/R(%)	T(°C)	ΔR/R(%)	T(°C)
0	3275	-5.2	3.5	0.7	5.0	1.0
25	1000	-4.4	3.0	0.7	4.5	1.1
55	300	-3.7	3.5	1.0	4.0	1.1
85	109	-3.1	4.1	1.3	3.4	1.1
100	69.4	-2.9	4.5	1.6	3.0	1.0

Only the Design 2 is able to meet the requirement $T \approx 1^{\circ}\text{C}$ from 25°C to 100°C.

NTC THERMISTORS

General Characteristics

2.1.9. Shaping of the R (T) characteristic

By the use of a resistor network, it is possible to modify the R (T) characteristic of a thermistor so that it matches the required form, for example a linear response over a restricted temperature range.

A single fixed resistor R_p placed in parallel with a thermistor gives a S-shape resistance-temperature curve (see Figure 2) which is substantially more linear at the temperature range around the inflexion point (R_0, T_0).

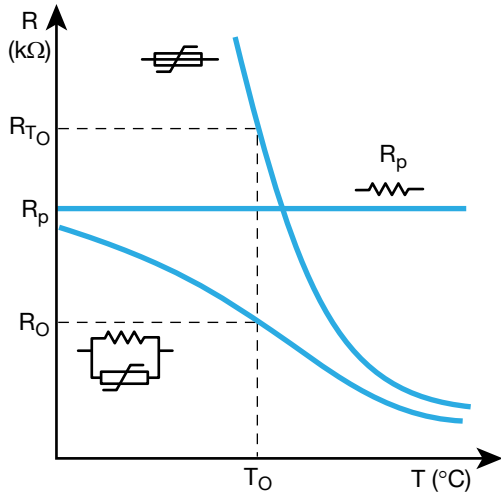

Figure 2 – Linearization of a thermistor

It can be calculated that better linearization is obtained when the fixed resistor value and the mid-range temperature are related by the formula:

$$R_p = R_{T_0} \times \frac{B - T_0}{B + 2T_0}$$

For example, with a thermistor ND03N00103J –

$$R_{25^\circ\text{C}} = 10\text{k}\Omega, B = 4080\text{ K}$$

good linearization is obtained with a resistor in parallel where the value is:

$$R_p = 10,000\ \Omega \times \frac{4080 - 298}{4080 + (2 \times 298)} = 8088\ \Omega$$

2.2 CHARACTERISTICS WITH ENERGY DISSIPATION

When a current is flowing through an NTC thermistor, the power due to the Joule effect raises the temperature of the NTC above ambient.

The thermistor reaches a state of equilibrium when the power supplied becomes equal to the power dissipated in the environment.

The thermal behavior of the thermistor is mainly dependent on the size, shape and mounting conditions.

Several parameters have been defined to characterize these properties:

2.2.1. Heat capacity (H)

The heat capacity is the amount of heat required to change the temperature of the thermistor by 1°C and is expressed in J/°C.

2.2.2. Dissipation factor ()

This is the ratio between the variation in dissipated power and the variation of temperature of the NTC. It is expressed in mW/°C and may be measured as:

$$\delta = \frac{U.I}{85 - 25}$$

where U.I is the power necessary to raise to 85°C the temperature of a thermistor maintained in still air at 25°C.

2.2.3. Maximum permissible temperature (T max)

This is the maximum ambient temperature at which the thermistor may be operated with zero dissipation. Above this temperature, the stability of the resistance and the leads attachment can no longer be guaranteed.

2.2.4. Maximum permissible power at 25°C (Pmax)

This is the power required by a thermistor maintained in still air at 25°C to reach the maximum temperature for which it is specified.

For higher ambient temperatures, the maximum permissible power is generally derated according to the Figure 3 here after and $T_L = T_{\text{max}} - 10^\circ\text{C}$.

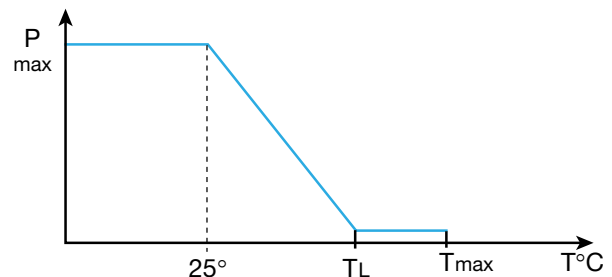

Figure 3 – Derating of maximum power

General Characteristics

2.2.5. Voltage – Current curves V (I)

These curves describe the behavior of the voltage drop V measured across the NTC as the current I through the NTC is increased.

They describe the state of equilibrium between power resulting from Joule effect and dissipated power in the surroundings. (Figure 4)

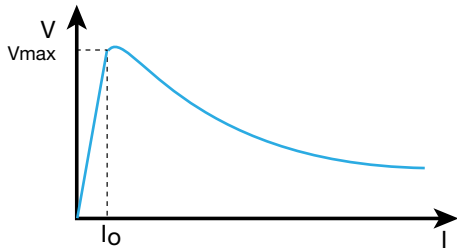

Figure 4 – Voltage – current curve V (I)

Several zones can be identified:

- low current zone
dissipated energy only produces negligible heating and the curve V (I) is almost linear.
- non-linear zone
the curve V (I) displays a maximum voltage Vmax for a current Io. This maximum voltage Vmax and the temperature Tmax reached by the NTC under these conditions can be determined by using the equations:

$$P = V^2/R = \delta (T - T_{amb}) \quad \text{and}$$

$$R = R_{amb} \cdot \exp B (1/T - 1/T_{amb})$$

therefore:

$$T_{max} = B/2 - \sqrt{B^2/4 - BT_{amb}} \approx T_{amb} \left(1 + \frac{T_{amb}}{B}\right)$$

$$V_{max} = \sqrt{\delta (T_{max} - T_{amb}) \cdot R_{amb} \exp \left[B \left(\frac{1}{T_{max}} - \frac{1}{T_{amb}} \right) \right]}$$

where δ is the dissipation factor and T_{amb} is the ambient temperature.

- high current zone
for higher currents, an increase in temperature of the NTC decreases the resistance and the voltage more rapidly than the increase of the current. Above a certain dissipated power, the temperature of the NTC exceeds the permissible value.

2.2.6. Current – Time curves I(t)

When voltage is applied to a thermistor, a certain amount of time is necessary to reach the state of equilibrium described by the V(I) curves.

This is the heating up time of the thermistor which depends on the voltage and the resistance on one side and the heat capacity and dissipation on the other.

The curves I(t) are of particular interest in timing applications.

2.2.7. Thermal time constant

When a thermistor is self-heated to a temperature T above ambient temperature T_{amb} , and allowed to cool under zero power resistance, this will show a transient situation.

At any time interval dt, dissipation of the thermistor ($\delta(T - T_{amb})dt$) generates a temperature decrease $-HdT$, resulting in the equation:

$$\frac{1}{(T - T_{amb})} dT = - \frac{\delta}{H} dt$$

The solution to this equation for any value of t, measured from $t = 0$, is:

$$\ln \frac{(T - T_{amb})}{(T_0 - T_{amb})} = - \frac{\delta}{H} t$$

We can define a thermal time constant τ as:

$$\tau = H/\delta \quad \text{expressed in seconds.}$$

Where the time $t = \tau$:

$$(T - T_{amb}) / (T_0 - T_{amb}) = \exp -1 = 0.368$$

expressing that for $t = \tau$, the thermistor cools to 63.2% of the temperature difference between the initial T_0 and T_{amb} (see Figure 5).

According to IEC 539 our technical data indicates τ measured with $T_0 = 85^\circ\text{C}$, $T_{amb} = 25^\circ\text{C}$ and consequently $T = 47.1^\circ\text{C}$.

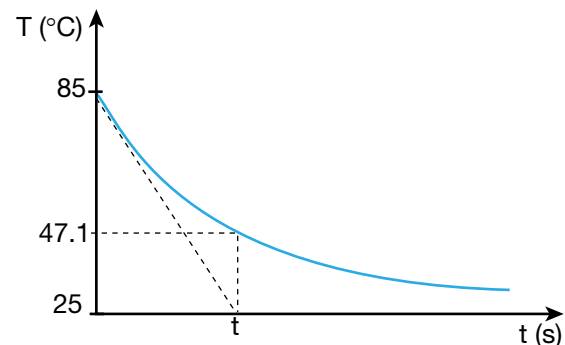

Figure 5 – Temperature – time curve T(t)

2.2.8. Response time

More generally, it is possible to define a response time as the time the thermistor needs to reach 63.2% of the total temperature difference when submitted to a change in the thermal equilibrium (for example from 60°C to 25°C in silicone oil 47V20 Rhodorsil).

NTC THERMISTORS

Application Notes

TEMPERATURE MEASUREMENT

High sensitivity and low cost make NTC thermistors the most common device used for temperature measurement.

Non-linearity of the R-T curve generally leads to the use of a resistor network to linearize the signal. An example is given in Figure 6.

More precise measurements and temperature display can also be achieved with simple electronic equipment as shown in Figure 7.

The choice of the model will particularly take into account the small size (better response time) and the resistance tolerance. Mounting conditions (dissipation), and input voltage (self-heating) will also be carefully defined to avoid serious errors in temperature measurement.

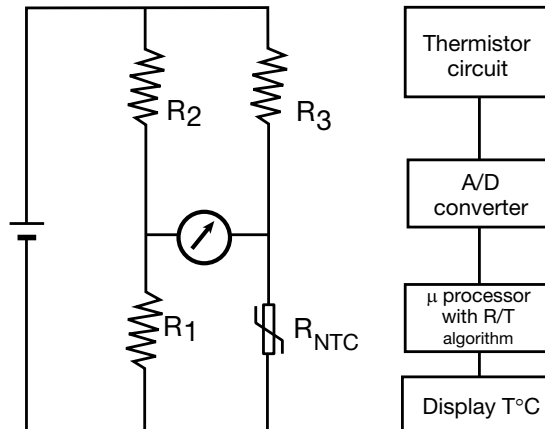

Figure 6

Figure 7

TEMPERATURE CONTROL AND ALARM

NTC thermistors can be used as a simple on-off control temperature system or temperature alarm system. Figure 8 gives an example of such a circuit.

When the temperature increases to a defined value, the resistance of the thermistor decreases and the current becomes sufficiently high to energize the relay and provide temperature alarm or heating system turn-off.

The high sensitivity of thermistors (about 4% resistance change for 1°C) allows the temperature to be controlled very precisely.

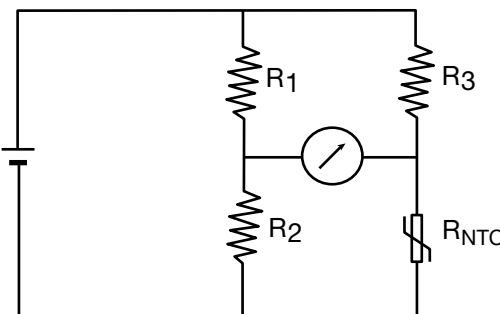

Figure 8

TEMPERATURE COMPENSATION

As many electronic components (integrated circuits, amplifiers,...) have a positive temperature coefficient of resistance, NTC thermistors represent a cheap and interesting solution to compensate for this effect and provide an improved temperature stability for electronic equipment.

It is necessary to include the thermistor in a resistor network (Figure 10) calculated in such a manner that the network coefficient compensates exactly for the positive temperature coefficient of the other component (Figure 9).

Common leaded discs or chip thermistors are well suited for this application.

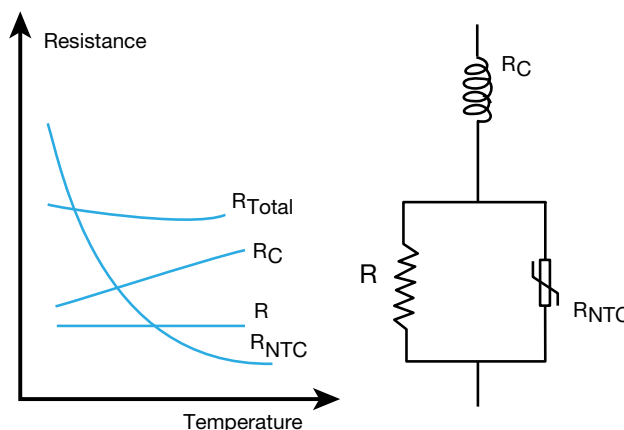

Figure 9

Figure 10

LIQUID LEVEL OR FLOW DETECTION

The dissipation of a thermistor is significantly different in a liquid or in a gas, in a static fluid or in a stirred one. A liquid level detector or a gas-flow measurement can be designed using this property.

In Figure 11, the output voltage measured on the thermistor depends upon the dissipation factor of its environment, and can be illustrated by V-I curves (Figure 12).

This voltage can be used to detect the presence (V_2) or absence (V_1) of liquid around the thermistor or measure the flow speed.

A good design should define a precise operating temperature range, where dissipation in the high dissipating medium at highest ambient temperature remains higher than the dissipation in low dissipating medium at lowest ambient temperature.

SURGE PROTECTION

A soft start of sensitive apparatus can be achieved by using NTC thermistors as described in Figures 13 and 14.

At turn-on, the NTC absorbs the surge current, limits the current across the equipment and protects it. Then, the thermistor heats, its resistance decreases and most of the power becomes applied to the apparatus.

In its design, the thermistor will be selected with a thermal capacity higher than the surge energy to absorb.

TIME DELAY

The current-time characteristic of a thermistor is used in time delay applications such as delaying energization of a relay after application of power to an electrical circuit.

The time delay, time necessary for the thermistor to heat up to the temperature where its resistance allows the current to reach the switching value of the relay, is mainly defined with the nominal resistance of the thermistor.

The time delay is also strongly dependent upon the ambient temperature, as shown in Figure 15.

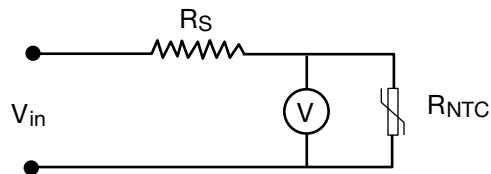

Figure 11

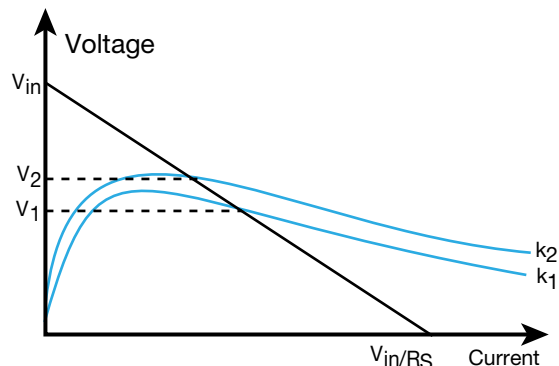

Figure 12

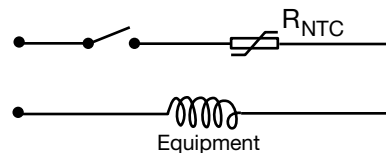

Figure 13

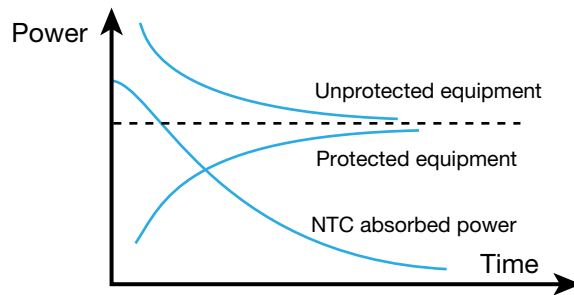

Figure 14

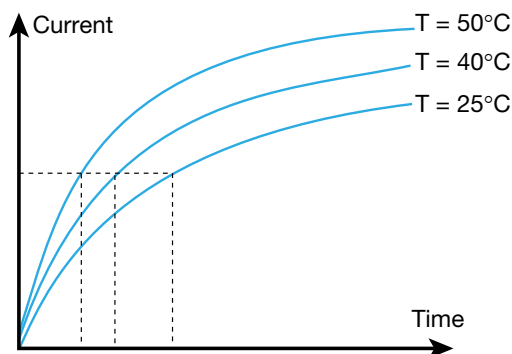

Figure 15

NTC SMD THERMISTORS

NB 21 (Ni Barrier/100% Sn Termination)



Chip thermistors are high quality and low cost devices especially developed for surface mounting applications. They are widely used for temperature compensation but can also achieve temperature control of printed circuits.

A nickel barrier metallization provides outstanding qualities of solderability and enables this chip to meet the requirements of the most severe soldering processes including lead free soldering with peak temperatures up to 270°C.

Types	NB 21 IEC SIZE : 0603
DIMENSIONS: millimeters (inches)	
Terminations	Nickel Barrier/100% Tin
Marking	On packaging only
Climatic category	40/125/56
Operating temperature	-55°C to +150°C
Tolerance on R _n (25°C)	±3%*, ±5%, ±10%, ±20%
Maximum dissipation at 25°C	0.07 W
Thermal dissipation factor	1 mW/°C
Thermal time constant	4 s

Resistance - Temperature characteristics: pages 29 to 33.

FEATURES

- Fast thermal response
- Commercial, Industrial and Automotive Applications
- Ni Barrier/100% Sn Termination
- Suitable for lead free reflow or wave soldering
- AEC-Q200 based qualification

APPLICATIONS

- LCD compensation
- Battery packs
- Mobile phones
- CD players
- Heating systems
- Air-conditioning systems
- Refrigeration
- Temperature control of Switch Mode Power Supplies
- Compensation of pressure sensors
- Protection of power transistors in various electronic circuits and more



HOW TO ORDER

NB 21	K 0	0103	M	BB
Type	Material Code	Resistance	Tolerance	Suffix: Packaging
NB21 (0603)	K (See tables pages 11)	10,000 Ω (See tables page 11)	H (±3%)* J (±5%) K (±10%) M (±20%)	--: Bulk (5000 pcs/bag) BB: Cardboard tape (180mm diam. reel, 4000 pcs/reel) BF: Cardboard tape (1/2 reel, 2000 pcs/reel) BD: Cardboard tape (330mm diam. reel, 10,000 pcs/reel)

* Optional tolerance, please contact factory



The Important Information/Disclaimer is incorporated in these specifications by reference and should be reviewed in full before placing any order.

NTC SMD THERMISTORS

NB 21 (Ni Barrier/100% Sn Termination)



TABLE OF VALUES

NB 21 IEC SIZE : 0603				
Types	Rn at 25°C (Ω)	Material Code	B (K) ($\Delta B/B$ (1) ± 5% (2) ± 3%)	α at 25°C (%/°C)
NB 21 KC 0 470 NB 21 KC 0 101 NB 21 KC 0 471	47 100 470	KC	3470 ± 5%	- 3.9
NB 21 MC 0 102	1,000	MC	3910 ± 3%	- 4.4
NB 21 J 0 0472 NB 21 J 0 0502	4,700 5,000	J	3480 ± 3%	- 3.9
NB 21 J 5 0682 NB 21 J 5 0103	6,800 10,000	J5	3480 ± 3%	- 3.9
NB 21 K 0 0103 NB 21 K 0 0153	10,000 15,000	K	3630 ± 3%	- 4.0
NB 21 L 0 0223	22,000	L	3790 ± 3%	- 4.2
NB 21 M 0 0333 NB 21 M 0 0473	33,000 47,000	M	3950 ± 3%	- 4.4
NB 21 M4 0 503	50,000	M4	4000 ± 3%	- 4.4
NB 21 L 2 0683	68,000	L2	3805 ± 3%	- 4.1
NB 21 N 0 0683	68,000	N	4080 ± 3%	- 4.6
NB 21 N 5 0104	100,000	N5	4160 ± 3%	- 4.7
NB 21 P 0 0154	150,000	P	4220 ± 3%	- 4.7
NB 21 Q 0 0334 NB 21 Q 0 0474	330,000 470,000	Q	4300 ± 3%	- 4.7

NTC SMD THERMISTORS

NB 12 - NB 20 (Ni Barrier/100% Sn Termination)



Chip thermistors are high quality and low cost devices especially developed for surface mounting applications. They are widely used for temperature compensation but can also achieve temperature control of printed circuits.

A nickel barrier metallization provides outstanding qualities of solderability and enables this chip to meet the requirements of the most severe soldering processes including lead free soldering with peak temperatures up to 270°C.

Types	NB 12 IEC SIZE : 0805	NB 20 IEC SIZE : 1206
DIMENSIONS: millimeters (inches)		
Terminations	Nickel Barrier/100% Tin	
Marking	On packaging only	
Climatic category	40/125/56	
Operating temperature	-55°C to +150°C	
Tolerance on R _n (25°C)	±3%*, ±5%, ±10%, ±20%	
Maximum dissipation at 25°C	0.12 W	0.24 W
Thermal dissipation factor	2 mW/°C	4 mW/°C
Thermal time constant	5 s	7s

Resistance - Temperature characteristics: pages 29 to 33.

FEATURES

- Fast thermal response
- Commercial, Industrial and Automotive Applications
- Ni Barrier/100% Sn Termination
- Suitable for lead free reflow or wave soldering
- AEC-Q200 based qualification

APPLICATIONS

- LCD compensation
- Battery packs
- Mobile phones
- CD players
- Heating systems
- Air-conditioning systems
- Refrigeration
- Temperature control of Switch Mode Power Supplies
- Compensation of pressure sensors
- Protection of power transistors in various electronic circuits and more



HOW TO ORDER

NB 20
Type
NB12 (0805)
NB20 (1206)

K 0
Material Code
K
(See tables pages 13)

0103
Resistance
10,000 Ω
(See tables page 13)

M
Tolerance
H (±3%)*
J (±5%)
K (±10%)
M (±20%)

BA
Suffix: Packaging
-- : Bulk (5000 pcs/bag)
NB20 BA: Plastic tape (180mm diam. reel, 3000 pcs/reel)
BE: Plastic tape (1/2 reel, 1500 pcs/reel)
BC: Plastic tape (330mm diam. reel, 10,000 pcs/reel)
NB12 BB: Cardboard tape (180mm diam. reel, 4000 pcs/reel)
BF: Cardboard tape (1/2 reel, 2000 pcs/reel)
BD: Cardboard tape (330mm diam. reel, 10,000 pcs/reel)

* Optional tolerance, please contact factory



The Important Information/Disclaimer is incorporated in these specifications by reference and should be reviewed in full before placing any order.

NTC SMD THERMISTORS

NB 12 - NB 20 (Ni Barrier/100% Sn Termination)



TABLE OF VALUES

NB 12 IEC SIZE : 0805				
Types	Rn at 25°C (Ω)	Material Code	B (K) (⁽¹⁾ ±5% (⁽²⁾ ±3%)	α at 25°C (%/°C)
NB 12 KC 0 180	18	KC	3470 ± 5%	- 3.9
NB 12 KC 0 220	22			
NB 12 KC 0 270	27			
NB 12 KC 0 330	33			
NB 12 KC 0 390	39			
NB 12 KC 0 470	47			
NB 12 KC 0 560	56			
NB 12 KC 0 680	68			
NB 12 KC 0 820	82			
NB 12 KC 0 101	100			
NB 12 MC 0 121	120	MC	3910 ± 3%	- 4.4
NB 12 MC 0 151	150			
NB 12 MC 0 181	180			
NB 12 MC 0 221	220			
NB 12 MC 0 271	270			
NB 12 MC 0 331	330			
NB 12 MC 0 391	390			
NB 12 MC 0 471	470			
NB 12 MC 0 561	560			
NB 12 MC 0 681	680			
NB 12 MC 0 821	820			
NB 12 MC 0 102	1,000			
NB 12 MC 0 122	1,200			
NB 12 MC 0 152	1,500			
NB 12 MC 0 182	1,800			
NB 12 MC 0 222	2,200			
NB 12 MC 0 272	2,700			
NB 12 MC 0 332	3,300			
NB 12 J 0 0332	3,300	J	3480 ± 3%	- 3.9
NB 12 J 0 0392	3,900			
NB 12 J 0 0472	4,700			
NB 12 J 0 0502	5,000			
NB 12 J 0 0562	5,600			
NB 12 K 0 0682	6,800	K	3630 ± 3%	- 4.0
NB 12 K 0 0822	8,200			
NB 12 K 0 0103	10,000			
NB 12 K 0 0123	12,000			
NB 12 L 0 0153	15,000			
NB 12 L 0 0183	18,000			
NB 12 M 0 0223	22,000	M	3950 ± 3%	- 4.4
NB 12 M 0 0273	27,000			
NB 12 M 0 0333	33,000			
NB 12 M 0 0393	39,000			
NB 12 N 0 0473	47,000	N	4080 ± 3%	- 4.6
NB 12 N 0 0503	50,000			
NB 12 N 0 0563	56,000			
NB 12 L 2 0683	68,000	L2	3805 ± 3%	- 4.1
NB 12 N 0 0823	82,000	N	4080 ± 3%	- 4.6
NB 12 P 0 0104	100,000	P	4220 ± 3%	- 4.7
NB 12 P 0 0124	120,000			
NB 12 P 0 0154	150,000			
NB 12 P 0 0184	180,000			
NB 12 Q 0 0224	220,000	Q	4300 ± 3%	-4.7

NB 20 IEC SIZE : 1206				
Types	Rn at 25°C (Ω)	Material Code	B (K) (⁽¹⁾ ±5% (⁽²⁾ ±3%)	α at 25°C (%/°C)
NB 20 MC 0 221	220	MC	3910 ± 3%	- 4.4
NB 20 MC 0 102	1,000	M C	3910 ± 3%	- 4.4
NB 20 J 0 0472	4,700	J	3480 ± 3%	- 3.9
NB 20 J 0 0502	5,000			
NB 20 J 0 0562	5,600			
NB 20 J 0 0682	6,800			
NB 20 J 5 0822	8,200	J5	3480 ± 3%	- 3.9
NB 20 K 0 0103	10,000	K	3630 ± 3%	- 4.0
NB 20 K 0 0123	12,000			
NB 20 L 0 0153	15,000	L	3790 ± 3%	- 4.2
NB 20 L 0 0183	18,000			
NB 20 L 0 0223	22,000			
NB 20 M 0 0273	27,000	M	3950 ± 3%	- 4.4
NB 20 M 0 0333	33,000			
NB 20 M 0 0393	39,000			
NB 20 M 0 0473	47,000			
NB 20 M 4 0503	50,000	M4	4000 ± 3%	- 4.4
NB 20 N 0 0563	56,000	N	4080 ± 3%	- 4.6
NB 20 N 0 0683	68,000			
NB 20 N 0 0823	82,000			
NB 20 N 5 0104	100,000	N5	4160 ± 3%	- 4.7
NB 20 P 0 0124	120,000	P	4220 ± 3%	- 4.7
NB 20 P 0 0154	150,000			
NB 20 P 0 0184	180,000			
NB 20 P 0 0224	220,000			
NB 20 Q 0 0274	270,000	Q	4300 ± 3%	- 4.7
NB 20 Q 0 0334	330,000			
NB 20 Q 0 0394	390,000			
NB 20 Q 0 0474	470,000			
NB 20 Q 0 0564	560,000	R	4400 ± 3%	- 4.8
NB 20 R 0 0684	680,000			
NB 20 R 0 0824	820,000			
NB 20 R 0 0105	1,000,000			

NTC SMD THERMISTORS

NC 21 (AgPdPt Termination)



Chip thermistors are high quality and low cost devices especially developed for surface mounting applications. They are widely used for temperature compensation but can also achieve temperature control of printed circuits.

Its silver-palladium-platinum metallization provides a high degree of resistance to dewetting of the terminations (typically 260°C / 15 s). Parts are suitable for hybrid assembly process (conductive adhesive), not suitable for lead free soldering.

Types	NC 21 IEC SIZE : 0603
DIMENSIONS: millimeters (inches)	
Terminations	PdPtAg
Marking	On packaging only
Climatic category	40/125/56
Operating temperature	-55°C to +150°C
Tolerance on R _n (25°C)	±3%*, ±5%, ±10%, ±20%
Maximum dissipation at 25°C	0.07 W
Thermal dissipation factor	1 mW/°C
Thermal time constant	4 s

Resistance - Temperature characteristics: pages 29 to 33.

FEATURES

- Fast thermal response
- Commercial, Industrial and Automotive Applications
- PdPtAg Termination
- Suitable for hybrid assembly (conductive adhesive)
- AEC-Q200 based qualification

APPLICATIONS

- LCD compensation
- Battery packs
- Mobile phones
- CD players
- Heating systems
- Air-conditioning systems
- Refrigeration
- Temperature control of Switch Mode Power Supplies
- Compensation of pressure sensors
- Protection of power transistors in various electronic circuits and more



HOW TO ORDER

NC 21	K 0	0103	M	BB
Type	Material Code	Resistance	Tolerance	Suffix: Packaging
NC21 (0603)	K (See tables pages 11)	10,000 Ω (See tables page 11)	H (±3%)* J (±5%) K (±10%) M (±20%)	--: Bulk (5000 pcs/bag) BB: Cardboard tape (180mm diam. reel, 4000 pcs/reel) BF: Cardboard tape (1/2 reel, 2000 pcs/reel) BD: Cardboard tape (330mm diam. reel, 10,000 pcs/reel)

* Optional tolerance, please contact factory



The Important Information/Disclaimer is incorporated in these specifications by reference and should be reviewed in full before placing any order.

NTC SMD THERMISTORS

NC 21 (Ni Barrier/100% Sn Termination)



TABLE OF VALUES

NC 21 IEC SIZE : 0603				
Types	Rn at 25°C (Ω)	Material Code	B (K) ($\frac{\Delta B}{B}$ ⁽¹⁾ ± 5% ₍₂₎ ± 3%)	α at 25°C (%/°C)
NC 21 KC 0 470 NC 21 KC 0 101 NC 21 KC 0 471	47 100 470	KC	3470 ± 5%	- 3.9
NC 21 MC 0 102	1,000	MC	3910 ± 3%	- 4.4
NC 21 J 0 0472 NC 21 J 0 0502	4,700 5,000	J	3480 ± 3%	- 3.9
NC 21 J 5 0682 NC 21 J 5 0103	6,800 10,000	J5	3480 ± 3%	- 3.9
NC 21 K 0 0103 NC 21 K 0 0153	10,000 15,000	K	3630 ± 3%	- 4.0
NC 21 L 0 0223	22,000	L	3790 ± 3%	- 4.2
NC 21 M 0 0333 NC 21 M 0 0473	33,000 47,000	M	3950 ± 3%	- 4.4
NC 21 M4 0 503	50,000	M4	4000 ± 3%	- 4.4
NC 21 L 2 0683	68,000	L2	3805 ± 3%	- 4.1
NC 21 N 0 0683	68,000	N	4080 ± 3%	- 4.6
NC 21 N 5 0104	100,000	N5	4160 ± 3%	- 4.7
NC 21 P 0 0154	150,000	P	4220 ± 3%	- 4.7
NC 21 Q 0 0334 NC 21 Q 0 0474	330,000 470,000	Q	4300 ± 3%	- 4.7

NTC SMD THERMISTORS

NC 12 – NC 20 (PdPtAg Termination)



Chip thermistors are a high quality and low cost device especially developed for surface mounting applications. They are widely used for temperature compensation but can also achieve temperature control of printed circuits. Its silver - palladium - platinum

metallization provides a high degree of resistance to dewetting of the terminations during soldering (typically 260°C / 15 s). Parts are suitable for hybrid assembly process, not suitable for lead free soldering.

Types	NC 12 IEC SIZE : 0805	NC 20 IEC SIZE : 1206
DIMENSIONS: millimeters (inches)		
Terminations	Silver – palladium – platinum metallization	
Marking	On packaging only	
Climatic category	40/125/56	
Operating temperature	-55°C to +150°C	
Tolerance on R _n (25°C)	±3%*, ±5%, ±10%, ±20%	
Maximum dissipation at 25°C	0.12 W	0.24 W
Thermal dissipation factor	2 mW/°C	4 mW/°C
Thermal time constant	5 s	7 s

Resistance - Temperature characteristics: pages 29 to 33.

FEATURES

- Fast thermal response
- Commercial, Industrial and Automotive Applications
- PdPtAg Termination
- Suitable for hybrid assembly
- AEC-Q200 based qualified

APPLICATIONS

- LCD compensation
- Battery packs
- Mobile phones
- CD players
- Heating systems
- Air-conditioning systems
- Refrigeration
- Temperature control of Switch Mode Power Supplies
- Compensation of pressure sensors
- Protection of power transistors in various electronic circuits and more



HOW TO ORDER

NC 20
Type
NC12 (0805)
NC20 (1206)

K 0
Material Code
K
(See tables pages 15)

0103
Resistance
10,000 Ω
(See tables page 15)

M
Tolerance
H (±3%)*
J (±5%)
K (±10%)
M (±20%)

BA
Suffix: Packaging
-- : Bulk (5000 pcs/bag)
NB20 BA: Plastic tape (180mm diam. reel, 3000 pcs/reel)
BE: Plastic tape (1/2 reel, 1500 pcs/reel)
BC: Plastic tape (330mm diam. reel, 10,000 pcs/reel)
NB12 BB: Cardboard tape (180mm diam. reel, 4000 pcs/reel)
BF: Cardboard tape (1/2 reel, 2000 pcs/reel)
BD: Cardboard tape (330mm diam. reel, 10,000 pcs/reel)

* Optional tolerance, please contact factory



The Important Information/Disclaimer is incorporated in these specifications by reference and should be reviewed in full before placing any order.

010617

NTC SMD THERMISTORS

NC 12 – NC 20 (PdPtAg Termination)



TABLE OF VALUES

NC 12 IEC SIZE : 0805				
Types	Rn at 25°C (Ω)	Material Code	B (K) ($\frac{\Delta B}{B}$) (1) ± 5% (2) ± 3%	α at 25°C (%/°C)
NC 12 KC 0 180	18	KC	3470 ± 5%	- 3.9
NC 12 KC 0 220	22			
NC 12 KC 0 270	27			
NC 12 KC 0 330	33			
NC 12 KC 0 390	39			
NC 12 KC 0 470	47			
NC 12 KC 0 560	56			
NC 12 KC 0 680	68			
NC 12 KC 0 820	82			
NC 12 KC 0 101	100			
NC 12 MC 0 121	120	MC	3910 ± 3%	- 4.4
NC 12 MC 0 151	150			
NC 12 MC 0 181	180			
NC 12 MC 0 221	220			
NC 12 MC 0 271	270			
NC 12 MC 0 331	330			
NC 12 MC 0 391	390			
NC 12 MC 0 471	470			
NC 12 MC 0 561	560			
NC 12 MC 0 681	680			
NC 12 MC 0 821	820			
NC 12 MC 0 102	1,000			
NC 12 MC 0 122	1,200			
NC 12 MC 0 152	1,500			
NC 12 MC 0 182	1,800			
NC 12 MC 0 222	2,200			
NC 12 MC 0 272	2,700			
NC 12 MC 0 332	3,300			
NC 12 J 0 0332	3,300	J	3480 ± 3%	- 3.9
NC 12 J 0 0392	3,900			
NC 12 J 0 0472	4,700			
NC 12 J 0 0502	5,000			
NC 12 J 0 0562	5,600			
NC 12 K 0 0682	6,800	K	3630 ± 3%	- 4.0
NC 12 K 0 0822	8,200			
NC 12 K 0 0103	10,000			
NC 12 K 0 0123	12,000			
NC 12 L 0 0153	15,000	L	3790 ± 3%	- 4.2
NC 12 L 0 0183	18,000			
NC 12 M 0 0223	22,000	M	3950 ± 3%	- 4.4
NC 12 M 0 0273	27,000			
NC 12 M 0 0333	33,000			
NC 12 M 0 0393	39,000	N	4080 ± 3%	- 4.6
NC 12 N 0 0473	47,000			
NC 12 N 0 0503	50,000			
NC 12 N 0 0563	56,000			
NC 12 L 2 0683	68,000	L2	3805 ± 3%	- 4.1
NC 12 N 0 0823	82,000	N	4080 ± 3%	- 4.6
NC 12 P 0 0104	100,000	P	4220 ± 3%	- 4.7
NC 12 P 0 0124	120,000			
NC 12 P 0 0154	150,000			
NC 12 P 0 0184	180,000			
NC 12 Q 0 0224	220,000	Q	4300 ± 3%	-4.7

NC 20 IEC SIZE : 1206				
Types	Rn at 25°C (Ω)	Material Code	B (K) ($\frac{\Delta B}{B}$) (1) ± 5% (2) ± 3%	α at 25°C (%/°C)
NC 20 KC 0 100	10	KC	3470 ± 5%	- 3.9
NC 20 KC 0 120	12			
NC 20 KC 0 150	15			
NC 20 KC 0 180	18			
NC 20 KC 0 220	22			
NC 20 KC 0 270	27			
NC 20 KC 0 330	33			
NC 20 KC 0 390	39			
NC 20 KC 0 470	47			
NC 20 KC 0 560	56			
NC 20 KC 0 680	68	MC	3910 ± 3%	- 4.4
NC 20 KC 0 820	82			
NC 20 KC 0 101	100			
NC 20 MC 0 121	120			
NC 20 MC 0 151	150			
NC 20 MC 0 181	180			
NC 20 MC 0 221	220			
NC 20 MC 0 271	270			
NC 20 MC 0 331	330			
NC 20 MC 0 391	390			
NC 20 MC 0 471	470			
NC 20 MC 0 561	560			
NC 20 MC 0 681	680			
NC 20 MC 0 821	820			
NC 20 MC 0 102	1,000			
NC 20 MC 0 122	1,200			
NC 20 MC 0 152	1,500			
NC 20 I 0 0182	1,800	I	3250 ± 5%	- 3.7
NC 20 I 0 0222	2,200			
NC 20 I 0 0272	2,700			
NC 20 I 0 0332	3,300	J	3480 ± 3%	- 3.9
NC 20 J 0 0392	3,900			
NC 20 J 0 0472	4,700			
NC 20 J 0 0502	5,000			
NC 20 J 0 0562	5,600			
NC 20 J 0 0682	6,800	K	3630 ± 3%	- 4.0
NC 20 K 0 0822	8,200			
NC 20 K 0 0103	10,000			
NC 20 K 0 0123	12,000			
NC 20 K 0 0153	15,000	L	3790 ± 3%	- 4.2
NC 20 L 0 0183	18,000			
NC 20 L 0 0223	22,000			
NC 20 M 0 0273	27,000	M	3950 ± 3%	- 4.4
NC 20 M 0 0333	33,000			
NC 20 M 0 0393	39,000			
NC 20 M 0 0473	47,000			
NC 20 M 4 0503	50,000	M4	4000 ± 3%	- 4.4
NC 20 N 0 0563	56,000	N	4080 ± 3%	- 4.6
NC 20 N 0 0683	68,000			
NC 20 N 0 0823	82,000			
NC 20 N 0 0104	100,000			
NC 20 P 0 0124	120,000	P	4220 ± 3%	- 4.7
NC 20 P 0 0154	150,000			
NC 20 P 0 0184	180,000			
NC 20 P 0 0224	220,000			
NC 20 Q 0 0274	270,000	Q	4300 ± 3%	- 4.7
NC 20 Q 0 0334	330,000			
NC 20 Q 0 0394	390,000			
NC 20 Q 0 0474	470,000			
NC 20 R 0 0564	560,000	R	4400 ± 3%	- 4.8
NC 20 R 0 0684	680,000			
NC 20 R 0 0824	820,000			
NC 20 R 0 0105	1,000,000			



PACKAGING FOR AUTOMATIC INSERTION



NTC Chip Thermistors / NC/NB Series

AUTOMATIC INSERTION

Super 8 Plastic Tape Packaging:

The mechanical and dimensional reel characteristics are in accordance with the IEC publication 286-3.

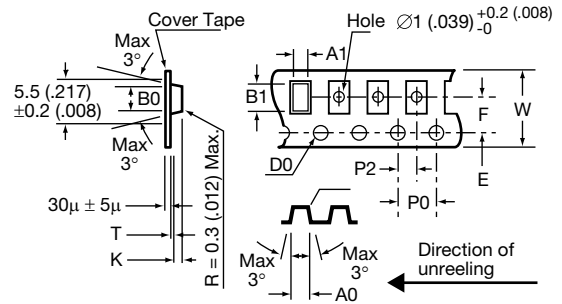

Designation	Symbol	Value	Tolerance	
Tape width	W	8	±0.2	
Tape thickness	T	0.4 max.		
Pitch of the sprocket holes	P0	4	±0.1	
Diameter of the sprocket holes	D0	1.5 -0	±0.1	
Distance	E	1.75	±0.1	
Distance (center to center)	F	3.5	±0.05	
Distance (center to center)	P2	2	±0.1	
Sizes of the cavities	NC 12 (0805)	A0	1.5	±0.1
		B0	2.4	±0.1
		K	1.4 max.	K ±0.1 (size is adjustable) (K = t1 +0.2)
	NC 20 (1206)	A0	1.95	±0.1
		B0	3.55	±0.1
		K	1.5 max.	K ±0.1 (size is adjustable) (K = t1 +0.2)

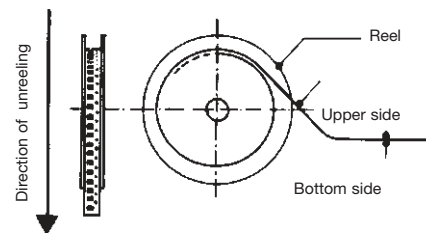
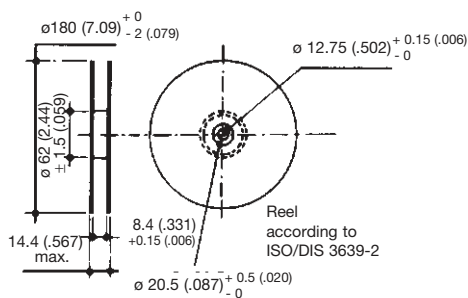

QUANTITY PER REEL

Type	Suffix	Description	Qty Per Reel
NB20 NC20	BA	Plastic tape (180mm diam. reel)	3,000 pcs
	BE	Plastic tape (1/2 reel)	1,500 pcs
	BC	Plastic tape (330mm diam. reel)	10,000 pcs



The Important Information/Disclaimer is incorporated in these specifications by reference and should be reviewed in full before placing any order.

PACKAGING FOR AUTOMATIC INSERTION



NTC Chip Thermistors / NC/NB Series

AUTOMATIC INSERTION

8mm Paper Tape Packaging:

The mechanical and dimensional reel characteristics are in accordance with the IEC publication 286-3.

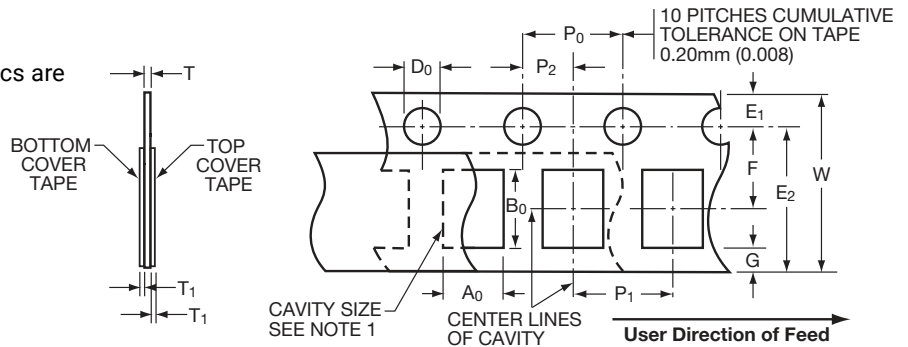

Designation	Symbol	Value	Tolerance	
Tape width	W	8	-0.1/+0.3	
Tape thickness	T	1.1 max.		
Pitch of the sprocket holes	P ₀	4	±0.1	
Diameter of the sprocket holes	D ₀	1.5	±0.1	
Distance	E ₁	1.75	±0.1	
Distance (center to center)	F	3.5	±0.05	
Distance (center to center)	P ₂	2	±0.05	
Cover tape thickness	T ₁	0.10 max.		
Distance	E ₂	6.25 min.		
Distance	G	0.75 min.		
Component pitch	P ₁	0805/0603	4	±0.1
		0402	2	±0.1

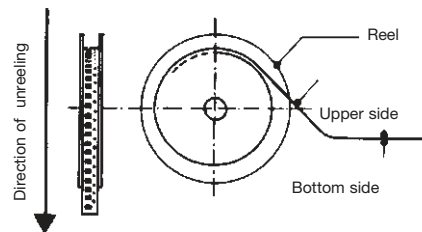
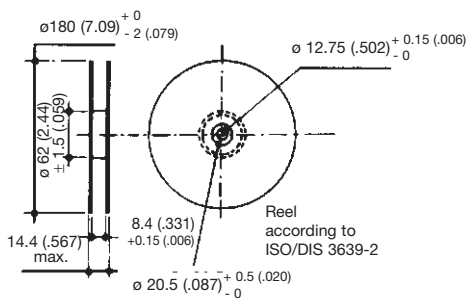

QUANTITY PER REEL

Type	Suffix	Description	Qty Per Reel
NB12	BB	Cardboard tape (180mm diam. reel)	4,000 pcs
NC12	BF	Cardboard tape (1/2 reel)	2,000 pcs
NB21	BD	Cardboard tape (330mm diam. reel)	10,000 pcs
NC21			



SURFACE MOUNTING GUIDE

Chip Thermistor – Application Notes



STORAGE

Good solderability is maintained for at least twelve months, provided the components are stored in their “as received” packaging at less than 40°C and 70% RH.

SOLDERABILITY / LEACHING

Terminations to be well soldered after immersion in a 60/40 tin/lead solder bath at 235 ± 5°C for 2 ± 1 seconds.

Terminations will resist leaching for at least the immersion times and conditions recommendations shown below.

P/N	Termination Type	Solder Tin/Lead	Solder Temp °C	Immersion Time Seconds
NC	AgPdPt	60/40	260 ± 5	15 max
NB	Nickel Barrier	60/40	260 ± 5	30 ± 1

NB products are compatible with a wide range of soldering conditions consistent with good manufacturing practice for surface mount components. This includes Pb free reflow processes with peak temperatures up to 270°C. Recommended profiles for reflow and wave soldering are shown below for reference.

NC products are recommended for lead soldering application or gluing techniques.

Wave

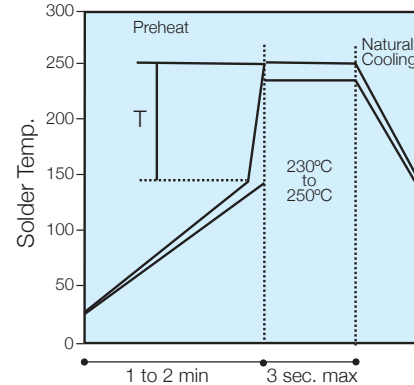

(Preheat chips before soldering)
T/maximum 150°C

- The visual standards used for evaluation of solder joints will need to be modified as lead free joints are not as bright as with tin-lead pastes and the fillet may not be as large.
- Resin color may darken slightly due to the increase in temperature required for the new pastes.
- Lead-free solder pastes do not allow the same self alignment as lead containing systems. Standard mounting pads are acceptable, but machine set up may need to be modified.

Reflow

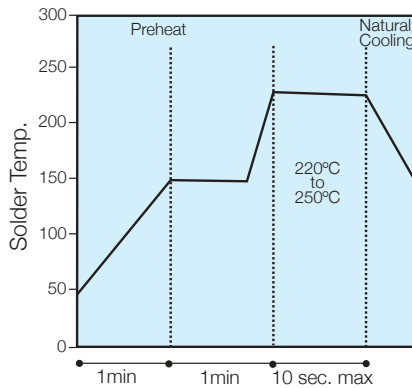

(Minimize soldering time)

RECOMMENDED SOLDERING PAD LAYOUT

Dimensions in mm (inches)

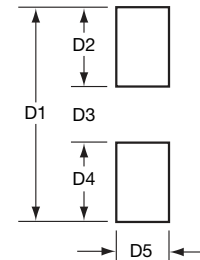

REFLOW SOLDERING

Case Size	P/N	D1	D2	D3	D4	D5
0603	NB21	2.30 (.091)	0.80 (.031)	0.70 (.028)	0.80 (.031)	0.75 (.030)
0805	NB12	3.00 (.118)	1.00 (.039)	1.00 (.039)	1.00 (.039)	1.25 (.049)
1206	NB20	4.00 (.157)	1.00 (.039)	2.00 (.079)	1.00 (.039)	2.50 (.098)

WAVE SOLDERING

Case Size	P/N	D1	D2	D3	D4	D5
0603	NB21	3.10 (.122)	1.20 (.047)	0.70 (.028)	1.20 (.047)	0.75 (.030)
0805	NB12	4.00 (.157)	1.50 (.059)	1.00 (.039)	1.50 (.059)	1.25 (.049)
1206	NB20	5.00 (.197)	1.50 (.059)	2.00 (.079)	1.50 (.059)	1.60 (.063)

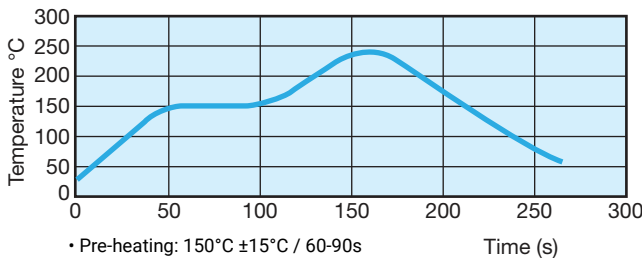

- Pre-heating: 150°C ±15°C / 60-90s
- Max. Peak Gradient: 2.5°C/s
- Peak Temperature: 245°C ±5°C
- Time at >230°C: 40s Max.



The Important Information/Disclaimer is incorporated in these specifications by reference and should be reviewed in full before placing any order.

NTC ACCURATE THERMISTORS

NP30 - NJ 28 – NI 24 – NK 20



High precision resistance and an outstanding ability to reproduce the sensibility index B, make these ranges of products the types of thermistors ideal for temperature measurement applications.

Leaded or unleaded, these small size and rapid response time

thermistors are able to meet the most accurate requirements.

FEATURES

- High Accuracy
- Fast thermal response
- Commercial, Industrial and Automotive Applications
- AEC-Q200 based qualification

OPTIONS

Consult factory for availability of options

- other nominal resistance values
- other tolerances
- controlled dimensions (e.g. reduced head size for NP30)
- alternative lead materials (e.g. steel, nickel)
- customized lead lengths, spacing, forming (kink) etc.
- epoxy coating on leads (NP30)

APPLICATIONS

- Temperature measurement
- Liquid level or flow detection
- Alarms and fire detectors
- HVAC and Refrigeration
- Fans
- Air intake temperature
- Electric pump module
- Water Temperature
- Evaporator probe
- and more

Types	NP 30	NJ 28	NI 24	NK 20
Finish	Coated chip with epoxy+ tinned copper wires	Coated chip with phenolic resin + varnish + tinned copper wires	Coated chip with epoxy AWG30 insulated leads + Silver plated nickel wires	Chip for Wire bonding
DIMENSIONS: millimeters (inches)				<p>Typical dimensions could differ for some modules</p>
Marking	On packaging only			
Operating temperature	-55°C to +150°C			
Tolerance on Rn (25°C)	±1%, ±2%, ±3%, ±5%			
Maximum dissipation at 25°C	0.16 W			
Thermal dissipation factor	4 mW/°C	3 mW/°C	1.5 mW/°C	2 mW/°C
Thermal time constant	9 s	8 s	16 s	6 s
Response time	< 2 s			

NTC ACCURATE THERMISTORS

NP30 - NJ 28 – NI 24 – NK 20



HOW TO ORDER

NP30

Type
NP30
NJ28
NI24
NK20

MA

Material Code
MA
(See table above)

0502

Resistance
5 kΩ
(See table above)

H

Tolerance
F (±1%)
G (±2%)
H (±3%)
J (±5%)

--

Packaging
--: Bulk
CA: Ammopack, H=16mm*
CB: Tape & Reel, H=16mm*
CC: Tape & Reel, H=19mm*
CD: Tape & Reel, H=19mm*

*Available for NP30 and NJ28 only
(See table page 25)

TABLE OF VALUES–NP30–NJ28–NI24–NK20

AVX PN	Rn at 25°C (Ω)	Available Rn Tol at 25°C	Material Code	B25/85 (K)	at 25°C (%/°C)
N__JA0501 ---	500	F, G, H, J	JA	3564±1%	-3.91
N__JA0102 ---	1,000	F, G, H, J	JA	3564±1%	-3.91
N__JA0202 ---	2,000	F, G, H, J	JA	3564±1%	-3.91
N__KA0202 ---	2,000	F, G, H, J	KA	3625±1%	-4.38
N__JA0212 ---	2,100	F, G, H, J	JA	3564±1%	-3.91
N__MA0222 ---	2,200	F, G, H, J	MA	3965±0.5%	-4.38
N__ME0222 ---	2,200	F, G, H, J	ME	3975±0.5%	-4.40
N__MA0272 ---	2,700	F, G, H, J	MA	3965±0.5%	-4.38
N__ME0272 ---	2,700	F, G, H, J	ME	3975±0.5%	-4.40
N__MN0272 ---	2,700	F, G, H, J	MN	4077±0.5%	-4.47
N__MA0282 ---	2,800	F, G, H, J	MA	3965±0.5%	-4.38
N__ME0282 ---	2,800	F, G, H, J	ME	3975±0.5%	-4.40
N__MN0282 ---	2,800	F, G, H, J	MN	4077±0.5%	-4.47
N__MA0302 ---	3,000	F, G, H, J	MA	3965±0.5%	-4.38
N__ME0302 ---	3,000	F, G, H, J	ME	3975±0.5%	-4.40
N__MN0302 ---	3,000	F, G, H, J	MN	4077±0.5%	-4.47
N__MA0392 ---	3,900	F, G, H, J	MA	3965±0.5%	-4.38
N__MN0392 ---	3,900	F, G, H, J	ME	3975±0.5%	-4.40
N__ME0392 ---	3,900	F, G, H, J	MN	4077±0.5%	-4.47
N__MA0472 ---	4,700	F, G, H, J	MA	3965±0.5%	-4.38
N__ME0472 ---	4,700	F, G, H, J	ME	3975±0.5%	-4.40
N__MN0472 ---	4,700	F, G, H, J	MN	4077±0.5%	-4.47
N__MA0502 ---	5,000	F, G, H, J	MA	3965±0.5%	-4.38
N__ME0502 ---	5,000	F, G, H, J	ME	3975±0.5%	-4.40
N__MN0502 ---	5,000	F, G, H, J	MN	4077±0.5%	-4.47
N__MA0512 ---	5,100	F, G, H, J	MA	3965±0.5%	-4.38
N__ME0512 ---	5,100	F, G, H, J	ME	3975±0.5%	-4.40
N__MN0512 ---	5,100	F, G, H, J	MN	4077±0.5%	-4.47

--- = Insert Product type (NP30, NJ28, NI24, NK20)

--- = Insert Tolerance and packaging code



The Important Information/Disclaimer is incorporated in these specifications by reference and should be reviewed in full before placing any order.

NTC ACCURATE THERMISTORS

NP30 - NJ 28 – NI 24 – NK 20



TABLE OF VALUES–NP30–NJ28–NI24–NK20

AVX PN	Rn at 25°C (Ω)	Available Rn Tol at 25°C	Material Code	B25/85 (K)	at 25°C (%/°C)
N__MA0602 ---	6,000	F, G, H, J	MA	3965±0.5%	-4.38
N__ME0602 ---	6,000	F, G, H, J	ME	3975±0.5%	-4.4
N__MN0602 ---	6,000	F, G, H, J	MN	4077±0.5%	-4.47
N__MA0702 ---	7,000	F, G, H, J	MA	3965±0.5%	-4.38
N__ME0702 ---	7,000	F, G, H, J	ME	3975±0.5%	-4.4
N__MN0702 ---	7,000	F, G, H, J	MN	4077±0.5%	-4.47
N__MA0802 ---	8,000	F, G, H, J	MA	3965±0.5%	-4.38
N__ME0802 ---	8,000	F, G, H, J	ME	3975±0.5%	-4.4
N__MN0802 ---	8,000	F, G, H, J	MN	4077±0.5%	-4.47
N__MA0103 ---	10,000	F, G, H, J	MA	3965±0.5%	-4.38
N__NA0103 ---	10,000	F, G, H, J	NA	4100±1%	-4.6
N__NA0123 ---	12,000	F, G, H, J	NA	4100±1%	-4.6
N__NA0153 ---	15,000	F, G, H, J	NA	4100±1%	-4.6
N__PA0203 ---	20,000	F, G, H, J	PA	4235±1%	-4.8
N__PA0253 ---	25,000	F, G, H, J	PA	4235±1%	-4.8
N__PA0303 ---	30,000	F, G, H, J	PA	4235±1%	-4.8
N__QA0473 ---	47,000	F, G, H, J	QA	4250±1%	-4.8
N__QA0503 ---	50,000	F, G, H, J	QA	4250±1%	-4.8
N__RA0104 ---	100,000	F, G, H, J	RA	4380±1%	-4.9
N__RA0154 ---	150,000	F, G, H, J	RA	4380±1%	-4.9
N__RA0204 ---	200,000	F, G, H, J	RA	4380±1%	-4.9

--- = Insert Product type (NP30, NJ28, NI24, NK20)

--- = Insert Tolerance and packaging code



NTC THERMISTORS MANUFACTURING PROCESS

NP30 - NJ 28 - NI 24 - NK 20

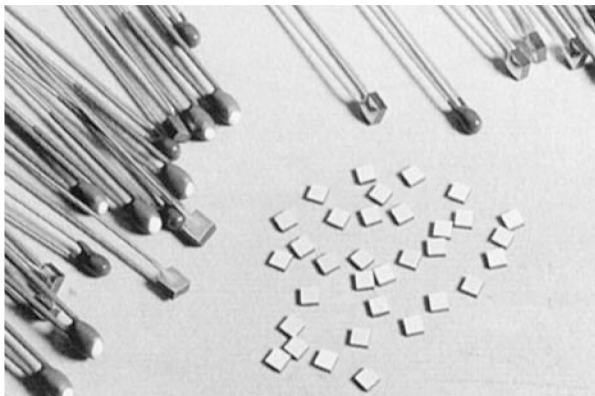
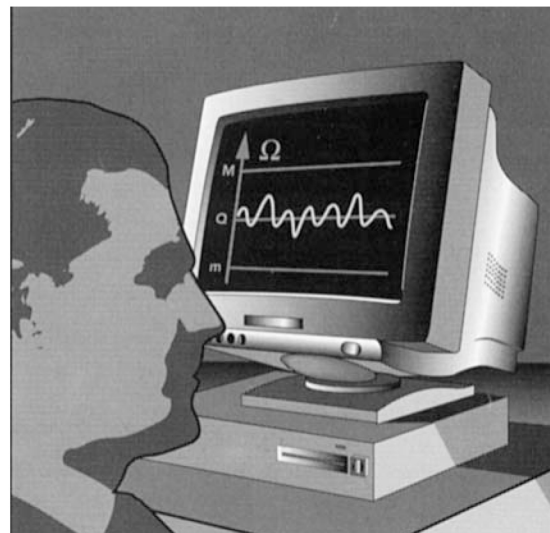
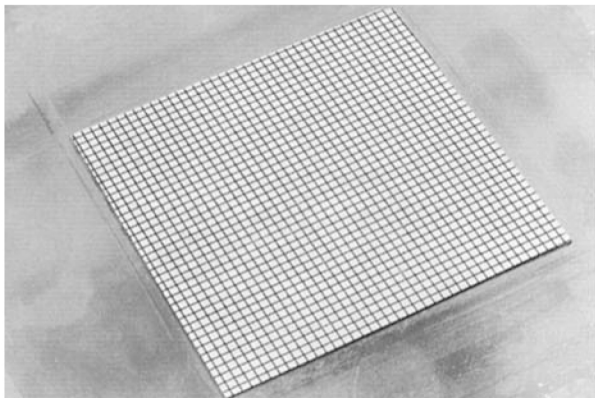
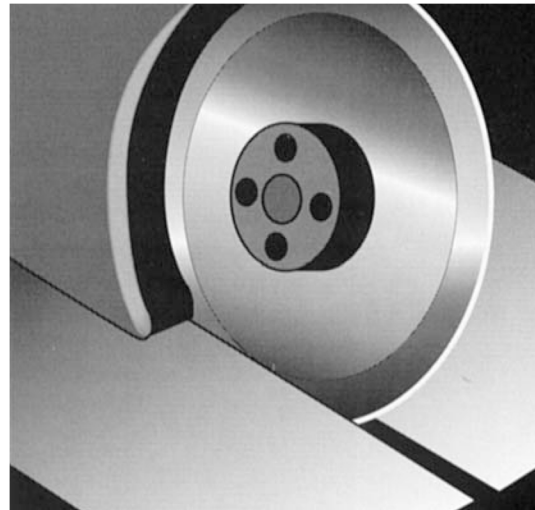
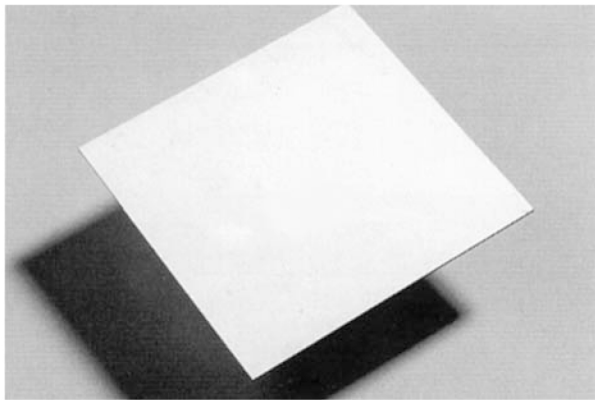
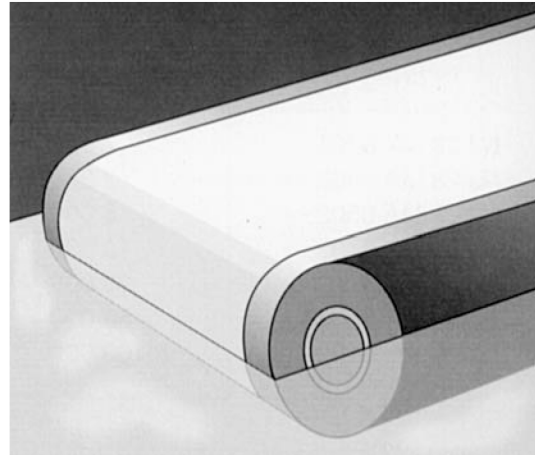

NTC DISC THERMISTORS

ND 03/06/09 – NE 03/06/09 – NV 06/09

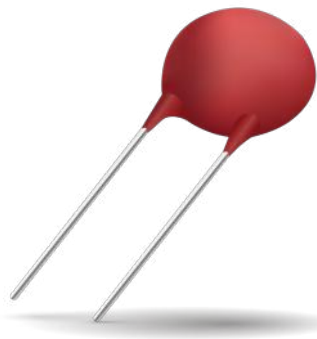

APPLICATIONS

- ND or NE: Commercial, Industrial and Automotive Applications AEC-Q200 based Qual
NV: Professional Applications
- Alarm and temperature measurement application
- Temperature regulation application
- Level detection application
- Compensation application and more

TECHNOLOGY

- ND: epoxy-phenolic resin coating
NE: epoxy resin coating (recommended for severe mounting conditions)
NV: epoxy varnish coating
- Leads: Radial copper wire tinned
- Marking: on package only for ND03 & NE03
ND/NE 06/09: Nominal resistance and tolerance for $\pm 5\%$, $\pm 10\%$
NV06/09: Nominal resistance and tolerance
- Delivery Mode: Bulk, reeled or ammopacked

PERFORMANCE CHARACTERISTICS

Types	General purpose			Professional	
	ND03 or NE03	ND06 or NE06	ND09 or NE09	NV06	NV09
Climatic category				55/125/56-434	55/125/56-434
Operating Temperature	-55 to +150°C	-55 to +150°C	-55 to +150°C	-55 to +150°C	-55 to +150°C
Tolerance on Rn (25°C)	330Ω to 1MΩ : $\pm \pm 3^*$, 5, 10, 20% 1500Ω to 150 kΩ : $\pm 3\%$	$\pm 3^*$, 5, 10, $\pm 20\%$	$\pm 3^*$, 5, 10, $\pm 20\%$	$\pm 2, 3, 5, \pm 10\%$	$\pm 2, 3, 5, \pm 10\%$
Maximum dissipation at 25°C	0.25 W	0.71 W	0.9 W	0.69 W	0.85 W
Thermal dissipation factor	5 mW/°C	7.1 mW/°C	9 mW/°C	6.9 mW/°C	8.5 mW/°C
Thermal time constant	10 s	22 s	30 s	18 s	30 s
Response time	< 3s				

STANDARDIZATION

NV range : approved by NFC 93271
 Type: TN115 A for NV06
 TN116 for NV09
 List: GAM-T1
 List: LNZ

* Optional tolerance, please contact factory

OPTIONS

Consult factory for availability of options:

- other nominal resistance values
- other tolerances
- alternative lead materials or lengths
- controlled dimensions



NTC DISC THERMISTORS

ND/NE 03



HOW TO ORDER

ND06

Type

ND03
NE03
ND06
NE06
NV06

ND09
NE09
NV09

P0

Material Code

P
(See tables
page 23-25)

0103

Resistance

10 k Ω
(See tables
page 22-24)

K

Tolerance

G ($\pm 2\%$) for NV
H ($\pm 3\%$)*
J ($\pm 5\%$)
K ($\pm 10\%$)
M ($\pm 20\%$)

--

Packaging

--: Bulk
Ammopack
(See table page 26)
Tape and reel
(See table page 26)

* Optional tolerance, please contact factory

TABLE OF VALUES ND03/NE03 TYPE

ND03/NE03

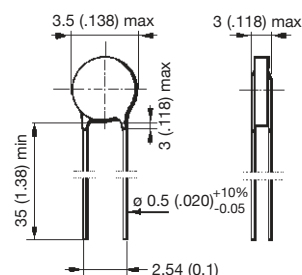

Part Number	R _n at 25°C (Ω)	Material Code	B (K) (B/B) (1) $\pm 5\%$ (2) $\pm 3\%$	α at 25°C (%/°C)
N_03J00681 N_03J00102	680 1,000	J	3480 (2)	- 3.9
N_03K00152 N_03K00222	1,500 2,200	K	3630 (2)	- 4.0
N_03L00272 N_03L00332	2,700 3,300	L	3790 (2)	- 4.2
N_03M00472 N_03M00682	4,700 6,800	M	3950 (2)	- 4.4
N_03N00103 N_03N00153	10,000 15,000	N	4080 (2)	- 4.6
N_03P00223 N_03P00333	22,000 33,000	P	4220 (2)	- 4.7
N_03Q00473 N_03Q00683	47,000 68,000	Q	4300 (2)	- 4.7
N_03R00104 N_03R00154	100,000 150,000	R	4400 (2)	- 4.8
N_03S00224	220,000	S	4520 (2)	- 5.0
N_03T00334 N_03T00474	330,000 470,000	T	4630 (2)	- 5.1
N_03U00105	1,000,000	U	4840 (2)	- 5.3



The Important Information/Disclaimer is incorporated in these specifications by reference and should be reviewed in full before placing any order.

NTC DISC THERMISTORS

ND/NE/NV 06



TABLE OF VALUES

ND06/NE06/NV06

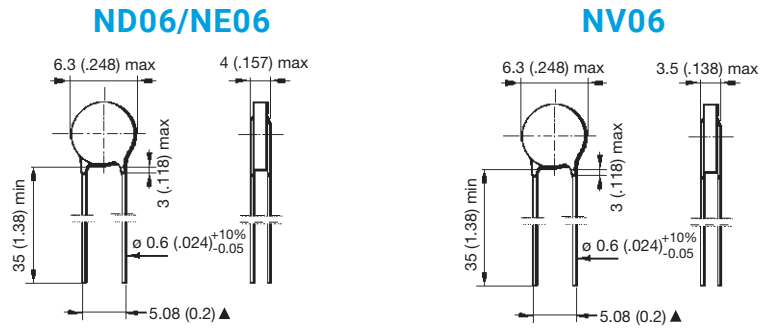

Part Number	R _n at 25°C (Ω)	Material Code	B (K) (B/B) (1) ± 5% (2) ± 3%	α at 25°C (%/°C)
N_06J00151	150	J	3480 (2)	- 3.9
N_06J00221	220			
N_06K00331	330	K	3630 (2)	- 4.0
N_06K00471	470			
N_06L00681	680	L	3790 (2)	- 4.2
N_06L00102	1,000			
N_06M00152	1,500	M	3950 (2)	- 4.4
N_06N00222	2,200			
N_06N00332	3,300	N	4080 (2)	- 4.6
N_06P00472	4,700			
N_06P00682	6,800	P	4220 (2)	- 4.7
N_06P00103	10,000			
N_06Q00153	15,000	Q	4300 (2)	- 4.7
N_06Q00223	22,000			
N_06R00333	33,000	R	4400 (2)	- 4.8
N_06S00473	47,000			
N_06S00683	68,000	S	4520 (2)	- 5.0
N_06T00104	100,000			
N_06U00154	150,000	U	4840 (2)	- 5.3
N_06U00224	220,000			
N_06U00334	330,000			

For other resistance values, please consult us.

NTC DISC THERMISTORS

ND/NE/NV 09



TABLE OF VALUES

ND09/NE09/NV09

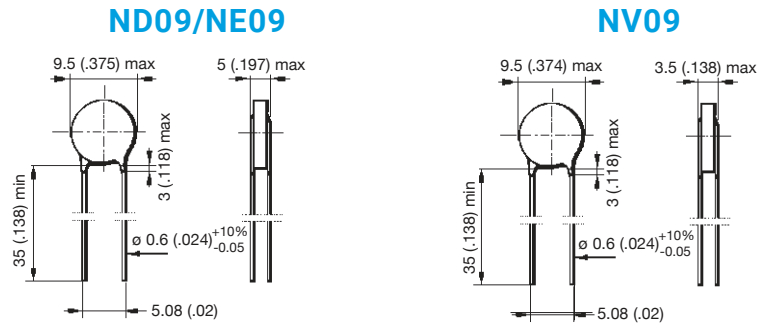

Part Number	Rn at 25°C (Ω)	Material Code	B (K) ($\frac{B}{B}$ (1) ± 5% (2) ± 3%)	α at 25°C (%/°C)
N_09J00680	68	J	3480 (2)	- 3.9
N_09J00101	100	J	3480 (2)	- 3.9
N_09K00151	150	K	3630 (2)	- 4.0
N_09K00221	220	K	3630 (2)	- 4.0
N_09L00331	330	L	3790 (2)	- 4.2
N_09M00471	470	M	3950 (2)	- 4.4
N_09M00681	680	M	3950 (2)	- 4.4
N_09N00102	1,000	N	4080 (2)	- 4.6
N_09N00152	1,500	N	4080 (2)	- 4.6
N_09P00222	2,200	P	4220 (2)	- 4.7
N_09P00332	3,300	P	4220 (2)	- 4.7
N_09Q00472	4,700	Q	4300 (2)	- 4.7
N_09Q00682	6,800	Q	4300 (2)	- 4.7
N_09R00103	10,000	R	4400 (2)	- 4.8
N_09R00153	15,000	R	4400 (2)	- 4.8
N_09S00223	22,000	S	4520 (2)	- 5.0
N_09T00333	33,000	T	4630 (2)	- 5.1
N_09T00473	47,000	T	4630 (2)	- 5.1
N_09U00683	68,000	U	4840 (2)	- 5.3
N_09U00104	100,000	U	4840 (2)	- 5.3
N_09U00154	150,000	U	4840 (2)	- 5.3



The Important Information/Disclaimer is incorporated in these specifications by reference and should be reviewed in full before placing any order.

010617

NTC DISC THERMISTORS

Packaging for Automatic Insertion



PACKAGING AND KINK SUFFIXES

Tables below indicate the suffixes to specify when ordering to get the required kink and packaging. For devices on tape, it is necessary to specify the height (H or Ho) which is the distance between the tape axis (sprocket holes axis) and the seating plane on the printed circuit board. The following types can be ordered on tape either in AMMOPACK (fan folder) or on REEL in accordance with IEC 286-2.

– Straight leads:

H represents the distance between the sprocket holes axis and the bottom plane of component body (base of resin or base of stand off).

– Kinked leads and flat leads:

Ho represents the distance between the sprocket holes axis and the base on the knee (kinked leads) or the bottom of the flat part (flat leads).

• Reel & Ammopack

millimeters (inches)

Types	Suffix	H or Ho	Leads	Quantity/Size	Packaging
ND/NE03 & NJ28	CA	16 ± 0.5 (0.630 ± 0.020)	Straight	3000	AMMOPACK
	CB	16 ± 0.5 (0.630 ± 0.020)	Straight	3000	REEL
	CC	19.5 ± 0.5 (0.768 ± 0.020)	Straight	3000	AMMOPACK
	CD	19.5 ± 0.5 (0.768 ± 0.020)	Straight	3000	REEL
NP30	CA	16 ± 0.5 (0.630 ± 0.020)	Straight	2000	AMMOPACK
	CB	16 ± 0.5 (0.630 ± 0.020)	Straight	2000	REEL
	CC	19.5 ± 0.5 (0.768 ± 0.020)	Straight	2000	AMMOPACK
	CD	19.5 ± 0.5 (0.768 ± 0.020)	Straight	2000	REEL
ND/NE/NV 06/09	DA	16 ± 0.5 (0.630 ± 0.020)	Straight	1500	AMMOPACK
	DB	16 ± 0.5 (0.630 ± 0.020)	Straight	1500	REEL
	DC	19.5 ± 0.5 (0.768 ± 0.020)	Straight	1500	AMMOPACK
	DD	19.5 ± 0.5 (0.768 ± 0.020)	Straight	1500	REEL
	DL	16 ± 0.5 (0.630 ± 0.020)	Kinked	1500	AMMOPACK
	DM	16 ± 0.5 (0.630 ± 0.020)	Kinked	1500	REEL
	DN	19.5 ± 0.5 (0.768 ± 0.020)	Kinked	1500	AMMOPACK
	DP	19.5 ± 0.5 (0.768 ± 0.020)	Kinked	1500	REEL

NTC

Type
ND03
NE03
NJ28
NP30

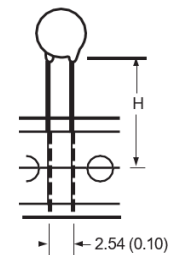

NTC

Types
ND/NE/NV
06/09

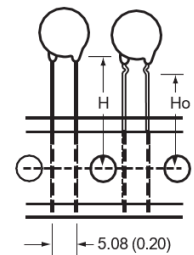

• Bulk

Type	Quantity/box
ND/NE03	3000
ND/NE06	1500
ND/NE09	1500
NV06	100
NV09	100
NI24 NJ28 NK20 NP30	1000

ND03 / NE03
NJ28 / NP30

ND/NE/NV
06/09

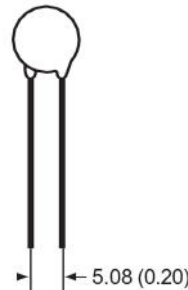
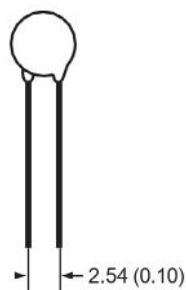

TAPING CHARACTERISTICS

Missing components

A maximum of 3 consecutive components may be missing from the bandolier, surrounded by at least 6 filled positions. The number of missing components may not exceed 0.5% of the total per packing module.

The beginning and the end of tape exhibit 8 or 9 blank positions.

DIMENSIONS: millimeters (inches)

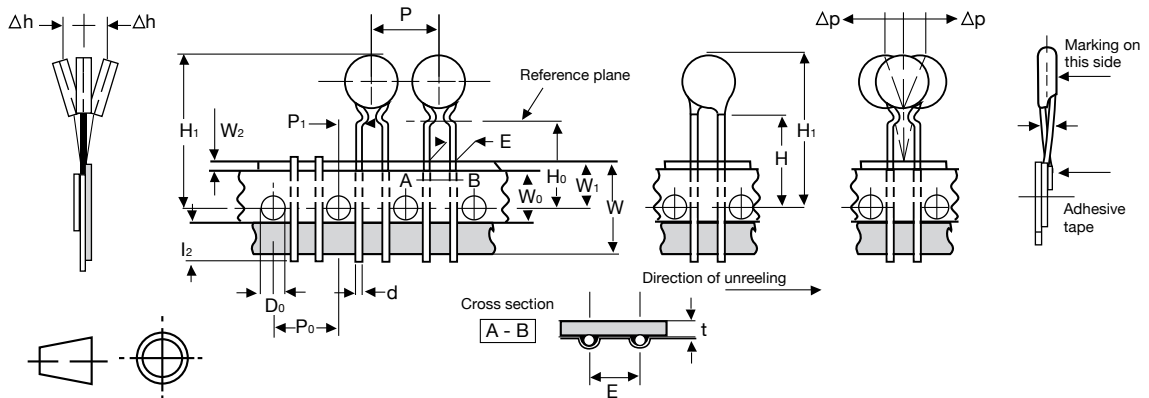
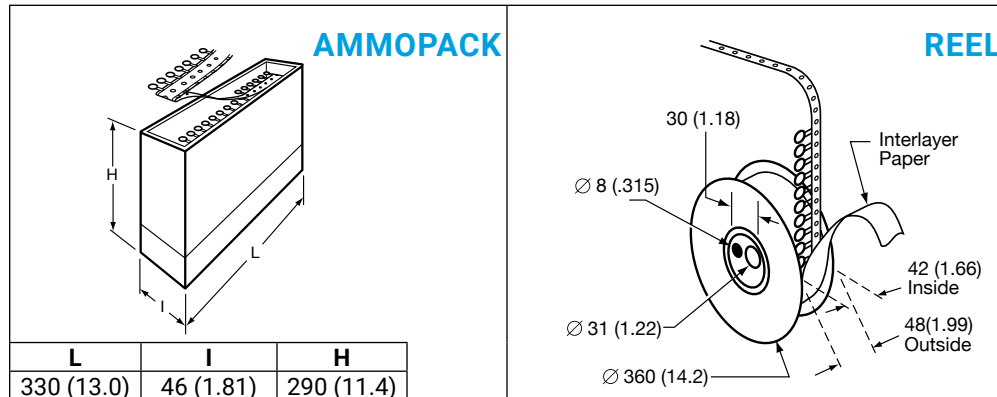

Value	Tolerance	Dimensions Characteristics	
18	+1 / -0.5	W	Leading tape width
6	±0.3	W ₀	Adhesive tape width
9	+0.75 / -0.5	W ₁	Sprocket hole position
3 max.		W ₂	Distance between the top of the tape and the adhesive
4	±0.2	D ₀	Diameter of sprocket hole
16/19.5	±0.5	H ₀	Distance between the tape axis and the seating plane of the component
		H ₁	Distance between the tape axis and the top of component body

Value	Tolerance	Dimensions Characteristics	
12.7	±0.2	P ₀	Sprocket holes pitch
254	±1	-	Distance between 21 consecutive holes 20 pitches
0.7	±0.2	t	Total thickness of tape
2.54 5.08	+0.6 -0.1	E	Lead spacing
5.08 3.85	± 0.7	P ₁	Distance between the sprocket hole axis and the lead axis
12.7	±1.0	P	Spacing of components
0.5 0.6	±5%	d	Lead diameter
0	±1.3	³ P	Verticality of components
0	±2	³ h	Alignment of components

This type of product is widely used in automotive and consumer applications.

They are assembled in custom-probes for sensing the temperature of liquids (water, oil, ...), gases or surface of any other component.

The metallization covers completely the surfaces of the thermistor.

The particularly flat and smooth surfaces ensure an excellent electrical and thermal contact under pressure.

Types	NR
Physical data (dim. in mm)	
Marking	On package only / On parts upon request
Operating temperature	-40°C to +200°C
Values and tolerances	Custom - designed products defined with: $D \pm D \quad R_1 \pm R_1/R_1 \text{ at } T_1$ $E \pm E \quad R_2 \pm R_2/R_2 \text{ at } T_2, \dots$

DESIGN OF THE THERMISTOR

Choice of the resistances

If the application is to measure the temperature around a defined point, a unique nominal resistance can be chosen (for example, among standard values of the ND range products presented on pages 20 to 24).

When it is required to measure the temperature over selected ranges $T_1 - T_2$, $T_2 - T_3$, ..., the corresponding resistance R_1 , R_2 , R_3 , ..., must be such that they can be located on the $R(T)$ characteristic of an existing NTC material (for example among standard materials whose $R(T)$ are displayed on pages 29 to 33).

The resistances must also be compatible with the resistivity of the material and the dimensions of the thermistor.

Choice of the tolerances

The precision of the temperature measurement determines the calculation of the tolerance on the resistance:

$$\Delta R/R = \alpha (\%/^{\circ}\text{C}) \cdot \Delta T (^{\circ}\text{C})$$

For example, the NTC NR55-3049-99, using "N5" material ($R(T)$ characteristic displayed on page 31), requires a precision of 1°C over the temperature range 110°C - 120°C.

The tolerances can be calculated:

$$\Delta R_{110^{\circ}\text{C}} / R_{110^{\circ}\text{C}} = 1^{\circ}\text{C} * 2.91\%/^{\circ}\text{C} = 2.91\%$$

$$\Delta R_{120^{\circ}\text{C}} / R_{120^{\circ}\text{C}} = 1^{\circ}\text{C} * 2.76\%/^{\circ}\text{C} = 2.76\%$$

*For your specific requirements, please consult us.

HOW TO ORDER

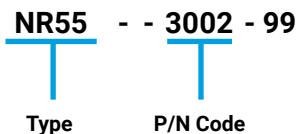

NTC LEADLESS DISC THERMISTORS



We present below some examples of our custom - designed products as an illustration of the different ways to define products.

DIMENSIONS: millimeters (inches)

Types	D	E	Material Code	B (k)	$R_1 \pm \Delta R_1$ at T_1	T_1 (°C)	$R_2 \pm \Delta R_2$ at T_2	T_2 (°C)	$R_3 \pm \Delta R_3$ at T_3	T_3 (°C)
NR 55 - 3002 - 99	5.5 (.217) ± 0.5 (.020)	1.1 (.043) ± 0.4 (.016)	N5	4160	1230 Ω ± 7.5%	40	160 Ω ± 5%	96.5	-	-
NR 67 - 3068 - 99	6.7 (.264) ± 0.5 (.020)	1.7 (.067) ± 0.3 (.012)	N	4080	150 Ω ± 3.3%	100	51 Ω ± 5.3%	140	-	-
NR 55 - 3049 - 99	5.5 (.217) ± 0.5 (.020)	1.0 (.040) ± 0.2 (.008)	N5	4160	107 Ω ± 2.9%	110	80.6 Ω ± 2.8%	120	-	-
NR 55 - 3046 - 99	5.5 (.217) ± 0.5 (.020)	1.3 (.051) ± 0.4 (.016)	S	4520	48600 Ω ± 7.5%	25	3210 Ω ± 5%	90	-	-
NR 49 - 3119 - 99	4.9 (.193) ± 0.3 (.012)	1.5 (.060) ± 0.4 (.016)	M	3950	840 Ω ± 10%	37.8	84 Ω ± 5%	104.4	-	-
NR 55 - 3114 - 99	5.5 (.217) ± 0.4 (.016)	1.0 (.040) ± 0.2 (.008)	P	4220	5000 Ω ± 10%	25	-	-	-	-
NR 70 - 3121 - 99	7.0 (.275) ± 0.3 (.012)	1.2 (.047) ± 0.2 (.008)	L	3790	210 Ω ± 10%	40	40 Ω ± 7.5%	90	30 Ω ± 6.7%	100
NR 29 - 3107 - 99	2.9 (.014) ± 0.3 (.012)	1.7 (.067) ± 0.3 (.012)	K	3630	2050 Ω ± 6%	25	193 Ω ± 5.4%	96.5	-	-
NR 55 - 3122 - 99	5.5 (.217) ± 0.5 (.020)	1.5 (.060) ± 0.4 (.016)	J	3480	210 Ω ± 5%	25	-	-	-	-
NR 55 - 3126 - 99	5.5 (.217) ± 0.5 (.020)	1.0 (.040) ± 0.2 (.008)	P	4220	3340 Ω ± 10%	25	264 Ω ± 7%	90	107 Ω ± 7%	120
NR 47 - 3116 - 99	4.7 (.185) ± 0.4 (.016)	1.2 (.047) ± 0.2 (.008)	R	4400	33000 Ω ± 2%	25	-	-	-	-
NR 49 - 3113 - 99	4.9 (.193) ± 0.3 (.012)	1.2 (.047) ± 0.2 (.008)	N	4080	1680 Ω ± 10%	40	382 Ω ± 6.7%	80	176 Ω ± 5%	105
NR 47 - 3101 - 99	4.6 (.181) ± 0.3 (.012)	1.4 (.055) ± 0.3 (.012)	J	3480	146 Ω ± 13%	40	22 Ω ± 10%	100	-	-
NR 55 - 3071 - 99	5.8 (.228) ± 0.3 (.012)	1.0 (.040) ± 0.2 (.008)	L	3790	262 Ω ± 8.7%	40	120 Ω ± 10%	60	35.5 Ω ± 7.8%	100
NR 61 - 3063 - 99	6.1 (.240) ± 0.3 (.012)	1.5 (.060) ± 0.3 (.012)	N	4080	760 Ω ± 9.2%	50	130 Ω ± 8.5%	100	56.6 Ω ± 8.5%	130
NR 67 - 3053 - 99	6.7 (.264) ± 0.4 (.016)	1.7 (.067) ± 0.3 (.012)	N	4080	540 Ω ± 11%	60	144 Ω ± 7%	100	-	-
NR 50 - 3048 - 99	5.0 (.197) ± 0.5 (.020)	1.5 (.060) ± 0.5 (.020)	J	3480	233 Ω ± 10%	25	13.3 Ω ± 7%	121	-	-
NR 60 - 3021 - 99	6.0 (.236) ± 0.5 (.020)	3.2 (.125) ± 0.3 (.012)	P	4220	3640 Ω ± 3%	40	457 Ω ± 3%	96.5	-	-
NR 55 - 3016 - 99	5.5 (.217) ± 0.5 (.020)	1.1 (.043) ± 0.4 (.016)	Q	4300	5500 Ω ± 9%	40	650 Ω ± 7.7%	96.5	-	-

Resistance - Temperature characteristics: pages 29 to 33.



The Important Information/Disclaimer is incorporated in these specifications by reference and should be reviewed in full before placing any order.

TABLES OF RESISTANCE VS TEMPERATURE



T (°C)	Material B(K)		
	I 3250		
	R(T) / R25	TF (%)	α (%/°C)
-55	42.35	21.9	-5.98
-50	31.48	20.0	-5.78
-45	23.63	18.1	-5.59
-40	17.91	16.3	-5.41
-35	13.70	14.6	-5.23
-30	10.58	13.1	-5.06
-25	8.232	11.6	-4.90
-20	6.460	10.1	-4.74
-15	5.110	8.8	-4.59
-10	4.072	7.5	-4.45
-5	3.268	6.3	-4.31
0	2.641	5.1	-4.18
5	2.148	4.0	-4.05
10	1.759	2.9	-3.92
15	1.449	1.9	-3.81
20	1.200	0.9	-3.69
25	1.000	0.0	-3.58
30	0.8377	0.9	-3.48
35	0.7054	1.8	-3.38
40	0.5969	2.6	-3.28
45	0.5076	3.5	-3.19
50	0.4336	4.3	-3.10
55	0.3720	5.1	-3.01
60	0.3206	5.9	-2.93
65	0.2774	6.6	-2.85
70	0.2410	7.4	-2.77
75	0.2102	8.1	-2.70
80	0.1839	8.8	-2.63
85	0.1616	9.5	-2.56
90	0.1424	10.2	-2.49
95	0.1259	10.9	-2.43
100	0.1117	11.5	-2.36
105	0.09938	12.2	-2.30
110	0.08869	12.8	-2.25
115	0.07938	13.4	-2.19
120	0.07124	14.0	-2.14
125	0.06410	14.6	-2.08
130	0.05783	15.2	-2.03
135	0.05230	15.7	-1.98
140	0.04741	16.3	-1.94
145	0.04308	16.8	-1.89
150	0.03924	17.4	-1.85

T (°C)	Material B(K)		
	J-J5 3480		
	R(T) / R25	TF (%)	α (%/°C)
-55	51.75	20.5	-6.23
-50	37.98	17.7	-6.03
-45	28.15	15.2	-5.84
-40	21.07	13.0	-5.65
-35	15.91	11.0	-5.48
-30	12.13	9.3	-5.31
-25	9.321	7.8	-5.15
-20	7.222	6.4	-4.99
-15	5.640	5.2	-4.84
-10	4.438	4.2	-4.69
-5	3.517	3.3	-4.55
0	2.807	2.5	-4.42
5	2.255	1.8	-4.29
10	1.824	1.2	-4.17
15	1.484	0.7	-4.05
20	1.215	0.3	-3.93
25	1.0000	0.0	-3.82
30	0.8278	0.3	-3.71
35	0.6889	0.7	-3.61
40	0.5763	1.1	-3.51
45	0.4845	1.5	-3.41
50	0.4092	2.0	-3.32
55	0.3472	2.5	-3.23
60	0.2960	3.0	-3.15
65	0.2533	3.5	-3.06
70	0.2177	4.1	-2.98
75	0.1879	4.7	-2.90
80	0.1628	5.3	-2.83
85	0.1415	5.9	-2.76
90	0.12349	6.5	-2.69
95	0.10813	7.1	-2.62
100	0.09499	7.7	-2.55
105	0.08372	8.4	-2.49
110	0.07402	9.0	-2.43
115	0.06564	9.7	-2.37
120	0.05837	10.3	-2.31
125	0.05206	11.0	-2.26
130	0.04656	11.6	-2.21
135	0.04175	12.3	-2.15
140	0.03753	13.0	-2.10
145	0.03382	13.6	-2.06
150	0.03055	14.3	-2.01

T (°C)	Material B(K)		
	K 3630		
	R(T) / R25	TF (%)	α (%/°C)
-55	56.27	21.4	-6.25
-50	41.22	18.5	-6.06
-45	30.48	15.9	-5.89
-40	22.74	13.6	-5.71
-35	17.11	11.5	-5.55
-30	12.98	9.7	-5.39
-25	9.931	8.1	-5.24
-20	7.655	6.7	-5.09
-15	5.945	5.4	-4.95
-10	4.651	4.4	-4.81
-5	3.663	3.4	-4.67
0	2.905	2.6	-4.54
5	2.319	1.9	-4.42
10	1.862	1.3	-4.30
15	1.505	0.8	-4.18
20	1.223	0.3	-4.07
25	1.0000	0.0	-3.96
30	0.8219	0.3	-3.85
35	0.6792	0.7	-3.75
40	0.5641	1.1	-3.65
45	0.4708	1.6	-3.55
50	0.3949	2.1	-3.46
55	0.3327	2.6	-3.37
60	0.2816	3.1	-3.28
65	0.2393	3.7	-3.20
70	0.2043	4.3	-3.12
75	0.1751	4.9	-3.04
80	0.1506	5.5	-2.96
85	0.1301	6.1	-2.89
90	0.1128	6.8	-2.82
95	0.09811	7.4	-2.75
100	0.08564	8.1	-2.68
105	0.07501	8.7	-2.61
110	0.06591	9.4	-2.55
115	0.05809	10.1	-2.49
120	0.05136	10.8	-2.43
125	0.04554	11.5	-2.37
130	0.04049	12.2	-2.32
135	0.03611	12.8	-2.26
140	0.03228	13.5	-2.21
145	0.02893	14.2	-2.16
150	0.02600	14.9	-2.11

T (°C)	Material B(K)		
	KA 3625		
	R(T) / R25	TF (%)	α (%/°C)
-55	61.22	7.1	-6.55
-50	44.25	6.1	-6.33
-45	32.34	5.3	-6.12
-40	23.88	4.5	-5.92
-35	17.81	3.8	-5.73
-30	13.41	3.2	-5.54
-25	10.19	2.7	-5.37
-20	7.815	2.2	-5.20
-15	6.041	1.8	-5.04
-10	4.707	1.5	-4.89
-5	3.696	1.1	-4.74
0	2.923	0.9	-4.60
5	2.329	0.6	-4.46
10	1.867	0.4	-4.33
15	1.507	0.3	-4.21
20	1.224	0.1	-4.09
25	1.0000	0.0	-3.97
30	0.8217	0.1	-3.86
35	0.6788	0.2	-3.75
40	0.5638	0.4	-3.65
45	0.4707	0.5	-3.55
50	0.3948	0.7	-3.46
55	0.3328	0.9	-3.37
60	0.2817	1.0	-3.28
65	0.2396	1.2	-3.19
70	0.2046	1.4	-3.11
75	0.1754	1.6	-3.03
80	0.1510	1.8	-2.96
85	0.1305	2.0	-2.88
90	0.1131	2.3	-2.81
95	0.09844	2.5	-2.74
100	0.08596	2.7	-2.68
105	0.07530	2.9	-2.61
110	0.06618	3.1	-2.55
115	0.05833	3.4	-2.49
120	0.05157	3.6	-2.43
125	0.04573	3.8	-2.38
130	0.04065	4.0	-2.32
135	0.03624	4.3	-2.27
140	0.03239	4.5	-2.22
145	0.02902	4.7	-2.17
150	0.02607	5.0	-2.12

T (°C)	Material B(K)		
	KC 3470		
	R(T) / R25	TF (%)	α (%/°C)
-55	60.08	34.0	-7.00
-50	43.19	29.4	-6.71
-45	31.42	25.3	-6.44
-40	23.13	21.6	-6.18
-35	17.22	18.4	-5.94
-30	12.95	15.5	-5.71
-25	9.842	12.9	-5.49
-20	7.550	10.7	-5.29
-15	5.845	8.7	-5.10
-10	4.564	6.9	-4.91
-5	3.594	5.4	-4.74
0	2.853	4.1	-4.58
5	2.281	3.0	-4.42
10	1.838	2.0	-4.27
15	1.491	1.2	-4.13
20	1.217	0.5	-4.00
25	1.0000	0.0	-3.90
30	0.8267	0.5	-3.74
35	0.6873	1.1	-3.63
40	0.5747	1.8	-3.52
45	0.4830	2.5	-3.41
50	0.4081	3.3	-3.31
55	0.3465	4.1	-3.21
60	0.2955	5.0	-3.12
65	0.2532	5.9	-3.03
70	0.2179	6.8	-2.94
75	0.1883	7.8	-2.86
80	0.1634	8.7	-2.78
85	0.1423	9.7	-2.71
90	0.1244	10.8	-2.63
95	0.10915	11.8	-2.56
100	0.09608	12.9	-2.50
105	0.08486	13.9	-2.43
110	0.07519	15.0	-2.37
115	0.06683	16.1	-2.31
120	0.05957	17.2	-2.25
125	0.05325	18.3	-2.20
130	0.04774	19.4	-2.14
135	0.04290	20.5	-2.09
140	0.03866	21.6	-2.04
145	0.03492	22.7	-1.99
150	0.03162	23.8	-1.95

T (°C)	Material B(K)		
	KC 3470		
	R(T) / R25	TF (%)	α (%/°C)
-55	82.54	22.3	-7.12
-50	58.03	19.3	-6.87
-45	41.31	16.6	-6.63
-40	29.75	14.2	-6.40
-35	21.68	12.0	-6.18
-30	15.97	10.1	-5.98
-25	11.88	8.5	-5.78
-20	8.931	7.0	-5.59
-15	6.777	5.7	-5.40
-10	5.188	4.5	-5.23
-5	4.007	3.6	-5.06
0	3.120	2.7	-4.90
5	2.449	2.0	-4.75
10	1.937	1.3	-4.60
15	1.543	0.8	-4.46
20	1.238	0.4	-4.33
25	1.0000	0.0	-4.20
30	0.8128	0.3	-4.07
35	0.6648	0.7	-3.95
40	0.5469	1.2	-3.84
45	0.4525	1.6	-3.73
50	0.3764	2.2	-3.62
55	0.3148	2.7	-3.52
60	0.2646	3.3	-3.42
65	0.2235	3.8	-3.33
70	0.1896	4.5	-3.24
75	0.1616	5.1	-3.15
80	0.1383	5.7	-3.07
85	0.1189	6.4	-2.98
90	0.1026	7.1	-2.91
95	0.08888	7.7	-2.83
100	0.07728	8.4	-2.76
105	0.06744	9.1	-2.69
110	0.05905	9.8	-2.62
115	0.05188	10.5	-2.56
120	0.04572	11.3	-2.49
125	0.04042	12.0	-2.43
130	0.03585	12.7	-2.37
135	0.03188	13.4	-2.32
140	0.02843	14.1	-2.26
145	0.02542	14.8	-2.21
150	0.02279	15.6	-2.16



TABLES OF RESISTANCE VS TEMPERATURE



T (°C)	Material B(K)		
	L2 3805		
	R(T) / R25	TF (%)	α (%/°C)
-55	62.45	22.4	-6.41
-50	45.40	19.3	-6.22
-45	33.33	16.6	-6.03
-40	24.70	14.2	-5.85
-35	18.47	12.1	-5.68
-30	13.92	10.2	-5.52
-25	10.58	8.5	-5.36
-20	8.110	7.0	-5.21
-15	6.260	5.7	-5.07
-10	4.867	4.6	-4.93
-5	3.810	3.6	-4.80
0	3.003	2.7	-4.67
5	2.382	2.0	-4.55
10	1.901	1.3	-4.43
15	1.526	0.8	-4.31
20	1.232	0.4	-4.20
25	1.0000	0.0	-4.10
30	0.8161	0.3	-4.00
35	0.6694	0.7	-3.90
40	0.5518	1.2	-3.80
45	0.4570	1.7	-3.71
50	0.3802	2.2	-3.62
55	0.3178	2.7	-3.53
60	0.2667	3.3	-3.45
65	0.2248	3.9	-3.37
70	0.1902	4.5	-3.29
75	0.1615	5.1	-3.22
80	0.1377	5.8	-3.14
85	0.1179	6.4	-3.07
90	0.1012	7.1	-3.00
95	0.08721	7.8	-2.94
100	0.07539	8.5	-2.87
105	0.06538	9.2	-2.81
110	0.05688	9.9	-2.75
115	0.04963	10.6	-2.69
120	0.04343	11.3	-2.63
125	0.03812	12.0	-2.58
130	0.03354	12.7	-2.53
135	0.02960	13.5	-2.47
140	0.02618	14.2	-2.42
145	0.02322	14.9	-2.37
150	0.02064	15.6	-2.33

T (°C)	Material B(K)		
	M 3950		
	R(T) / R25	TF (%)	α (%/°C)
-55	99.59	15.6	-7.42
-50	68.97	14.3	-7.16
-45	48.40	12.9	-6.91
-40	34.38	11.7	-6.67
-35	24.71	10.5	-6.45
-30	17.97	9.4	-6.23
-25	13.20	8.3	-6.02
-20	9.804	7.3	-5.82
-15	7.352	6.3	-5.63
-10	5.565	5.4	-5.45
-5	4.251	4.5	-5.28
0	3.275	3.7	-5.11
5	2.544	2.9	-4.95
10	1.992	2.1	-4.80
15	1.572	1.4	-4.65
20	1.249	0.7	-4.51
25	1.0000	0.0	-4.38
30	0.8057	0.7	-4.25
35	0.6534	1.3	-4.12
40	0.5331	1.9	-4.00
45	0.4376	2.5	-3.89
50	0.3612	3.1	-3.77
55	0.2998	3.7	-3.67
60	0.2501	4.3	-3.57
65	0.2097	4.8	-3.47
70	0.1767	5.3	-3.37
75	0.1496	5.9	-3.28
80	0.1272	6.4	-3.19
85	0.1087	6.9	-3.11
90	0.09320	7.4	-3.03
95	0.08025	7.8	-2.95
100	0.06937	8.3	-2.87
105	0.06019	8.8	-2.80
110	0.05242	9.2	-2.73
115	0.04580	9.6	-2.66
120	0.04016	10.1	-2.60
125	0.03532	10.5	-2.53
130	0.03117	10.9	-2.47
135	0.02758	11.3	-2.41
140	0.02448	11.7	-2.36
145	0.02179	12.1	-2.30
150	0.01945	12.4	-2.25

T (°C)	Material B(K)		
	MA 3965		
	R(T) / R25	TF (%)	α (%/°C)
-55	101.09	2.47	-7.49
-50	69.81	2.26	-7.22
-45	48.87	2.06	-6.96
-40	34.65	1.87	-6.71
-35	24.87	1.69	-6.48
-30	18.06	1.52	-6.26
-25	13.259	1.35	-6.05
-20	9.837	1.19	-5.84
-15	7.372	1.04	-5.65
-10	5.578	0.89	-5.47
-5	4.259	0.75	-5.29
0	3.280	0.61	-5.12
5	2.548	0.48	-4.96
10	1.994	0.35	-4.81
15	1.573	0.23	-4.66
20	1.250	0.11	-4.52
25	1.0000	0.00	-4.38
30	0.8054	0.11	-4.25
35	0.6528	0.22	-4.13
40	0.5324	0.32	-4.01
45	0.4368	0.42	-3.90
50	0.3603	0.52	-3.79
55	0.2989	0.61	-3.68
60	0.2492	0.70	-3.58
65	0.2088	0.79	-3.48
70	0.1758	0.88	-3.39
75	0.1487	0.96	-3.30
80	0.1263	1.04	-3.21
85	0.1078	1.12	-3.13
90	0.0923	1.20	-3.05
95	0.0794	1.27	-2.97
100	0.06857	1.35	-2.90
105	0.05942	1.42	-2.83
110	0.05167	1.49	-2.76
115	0.04509	1.55	-2.69
120	0.03948	1.62	-2.62
125	0.03467	1.68	-2.56
130	0.03055	1.75	-2.50
135	0.02699	1.81	-2.44
140	0.02392	1.87	-2.39
145	0.02125	1.93	-2.33
150	0.01894	1.98	-2.28

T (°C)	Material B(K)		
	MC 3910		
	R(T) / R25	TF (%)	α (%/°C)
-55	100.6	23.0	-7.56
-50	69.29	19.9	-7.27
-45	48.40	17.1	-7.00
-40	34.27	14.6	-6.75
-35	24.57	12.4	-6.50
-30	17.83	10.5	-6.27
-25	13.09	8.7	-6.05
-20	9.71	7.2	-5.84
-15	7.282	5.9	-5.64
-10	5.514	4.7	-5.45
-5	4.215	3.7	-5.27
0	3.250	2.8	-5.10
5	2.528	2.0	-4.93
10	1.982	1.4	-4.77
15	1.567	0.8	-4.62
20	1.247	0.4	-4.48
25	1.0000	0.0	-4.34
30	0.8072	0.4	-4.21
35	0.6559	0.8	-4.08
40	0.5362	1.2	-3.96
45	0.4410	1.7	-3.85
50	0.3647	2.2	-3.74
55	0.3033	2.8	-3.63
60	0.2535	3.4	-3.53
65	0.2130	4.0	-3.43
70	0.1798	4.6	-3.34
75	0.1525	5.2	-3.25
80	0.1300	5.9	-3.16
85	0.1112	6.6	-3.08
90	0.09552	7.3	-2.99
95	0.08239	8.0	-2.92
100	0.07133	8.7	-2.84
105	0.06199	9.4	-2.77
110	0.05406	10.1	-2.70
115	0.04731	10.9	-2.63
120	0.04153	11.6	-2.57
125	0.03658	12.3	-2.51
130	0.03231	13.1	-2.45
135	0.02863	13.8	-2.39
140	0.02544	14.6	-2.33
145	0.02267	15.3	-2.28
150	0.02025	16.1	-2.23

T (°C)	Material B(K)		
	ME 3975		
	R(T) / R25	TF (%)	α (%/°C)
-55	103.9	2.47	-7.56
-50	71.53	2.26	-7.28
-45	49.94	2.06	-7.01
-40	35.32	1.87	-6.76
-35	25.29	1.69	-6.53
-30	18.32	1.52	-6.30
-25	13.43	1.35	-6.08
-20	9.945	1.19	-5.88
-15	7.440	1.04	-5.68
-10	5.621	0.89	-5.50
-5	4.286	0.75	-5.32
0	3.297	0.61	-5.15
5	2.557	0.48	-4.98
10	2.000	0.35	-4.83
15	1.576	0.23	-4.68
20	1.251	0.11	-4.54
25	1.0000	0.00	-4.40
30	0.8048	0.11	-4.27
35	0.6519	0.22	-4.14
40	0.5313	0.32	-4.02
45	0.4356	0.42	-3.91
50	0.3591	0.52	-3.80
55	0.2977	0.61	-3.69
60	0.2481	0.70	-3.59
65	0.2078	0.79	-3.49
70	0.1749	0.88	-3.40
75	0.1479	0.96	-3.31
80	0.1256	1.04	-3.22
85	0.1071	1.12	-3.14
90	0.09175	1.20	-3.06
95	0.07890	1.27	-2.98
100	0.06810	1.35	-2.90
105	0.05900	1.42	-2.83
110	0.05130	1.49	-2.76
115	0.04476	1.55	-2.69
120	0.03918	1.62	-2.63
125	0.03441	1.68	-2.57
130	0.03031	1.75	-2.50
135	0.02678	1.81	-2.45
140	0.02373	1.87	-2.39
145	0.02108	1.93	-2.34
150	0.01878	1.98	-2.28

T (°C)	Material B(K)		
	M4 4400		
	R(T) / R25	TF (%)	α (%/°C)
-55	98.22	23.5	-7.38
-50	68.17	20.3	-7.12
-45	47.92	17.5	-6.88
-40	34.11	14.9	-6.64
-35	24.57	12.7	-6.42
-30	17.89	10.7	-6.20
-25	13.17	8.9	-6.00
-20	9.790	7.4	-5.80
-15	7.349	6.0	-5.62
-10	5.568	4.8	-5.44
-5	4.256	3.8	-5.27
0	3.280	2.8	-5.11
5	2.549	2.1	-4.95
10	1.996	1.4	-4.80
15	1.574	0.8	-4.66
20	1.250	0.4	-4.52
25	1.0000	0.0	-4.39
30	0.8049	0.4	-4.27
35	0.6519	0.8	-4.15
40	0.5311	1.2	-4.03
45	0.4352	1.7	-3.92
50	0.3586	2.3	-3.81
55	0.2970	2.8	-3.71
60	0.2472	3.4	-3.61
65	0.2068	4.1	-3.52
70	0.1738	4.7	-3.42
75	0.1468	5.4	-3.34
80	0.1245	6.0	-3.25
85	0.1060	6.7	-3.17
90	0.09060	7.4	-3.09
95	0.07776	8.2	-3.01
100	0.06700	8.9	-2.94
105	0.05793	9.6	-2.87
110	0.05026	10.4	-2.80
115	0.04376	11.1	-2.74
120	0.03822	11.9	-2.67
125	0.03349	12.6	-2.61
130	0.02944	13.4	-2.55
135	0.02595	14.1	-2.49
140	0.02294	14.9	-2.44
145	0.02033	15.6	-2.38
150	0.01807	16.4	-2.33



The Important Information/Disclaimer is incorporated in these specifications by reference and should be reviewed in full before placing any order.

TABLES OF RESISTANCE VS TEMPERATURE



T (°C)	Material B(K) MN 4077		
	R(T) / R25	TF (%)	α (%/°C)
-55	103.56	2.54	-7.39
-50	71.79	2.32	-7.14
-45	50.39	2.12	-6.90
-40	35.79	1.92	-6.68
-35	25.71	1.74	-6.46
-30	18.67	1.56	-6.25
-25	13.70	1.39	-6.06
-20	10.15	1.22	-5.87
-15	7.59	1.06	-5.68
-10	5.73	0.91	-5.51
-5	4.36	0.77	-5.34
0	3.35	0.63	-5.18
5	2.59	0.49	-5.03
10	2.02	0.36	-4.88
15	1.59	0.24	-4.74
20	1.26	0.12	-4.60
25	1.00	0.00	-4.47
30	0.80	0.11	-4.35
35	0.65	0.22	-4.23
40	0.52	0.33	-4.11
45	0.43	0.43	-4.00
50	0.35	0.53	-3.89
55	0.29	0.63	-3.79
60	0.24	0.72	-3.69
65	0.20	0.81	-3.59
70	0.17	0.90	-3.50
75	0.14	0.97	-3.41
80	0.12	1.07	-3.32
85	0.10	1.15	-3.24
90	0.09	1.23	-3.16
95	0.07	1.31	-3.08
100	0.06	1.38	-3.00
105	0.05	1.46	-2.93
110	0.05	1.53	-2.86
115	0.04	1.60	-2.79
120	0.04	1.67	-2.73
125	0.03	1.73	-2.66
130	0.03	1.80	-2.60
135	0.02	1.86	-2.54
140	0.02	1.92	-2.49
145	0.02	1.98	-2.43
150	0.02	2.04	-2.38

T (°C)	Material B(K) N 4080		
	R(T) / R25	TF (%)	α (%/°C)
-55	110.1	24.0	-7.50
-50	75.89	20.7	-7.25
-45	52.97	17.8	-7.01
-40	37.42	15.2	-6.78
-35	26.75	12.9	-6.56
-30	19.33	10.9	-6.35
-25	14.11	9.1	-6.14
-20	10.41	7.5	-5.95
-15	7.758	6.1	-5.76
-10	5.834	4.9	-5.58
-5	4.426	3.8	-5.41
0	3.387	2.9	-5.24
5	2.614	2.1	-5.08
10	2.033	1.4	-4.93
15	1.593	0.9	-4.78
20	1.258	0.4	-4.64
25	1.0000	0.0	-4.51
30	0.8004	0.4	-4.37
35	0.6449	0.8	-4.25
40	0.5228	1.3	-4.13
45	0.4264	1.8	-4.01
50	0.3497	2.3	-3.90
55	0.2885	2.9	-3.79
60	0.2392	3.5	-3.68
65	0.1994	4.1	-3.58
70	0.1671	4.8	-3.49
75	0.1406	5.5	-3.39
80	0.1189	6.2	-3.30
85	0.1010	6.9	-3.22
90	0.08616	7.6	-3.13
95	0.07381	8.3	-3.05
100	0.06347	9.1	-2.97
105	0.05480	9.8	-2.90
110	0.04748	10.6	-2.83
115	0.04129	11.3	-2.76
120	0.03603	12.1	-2.69
125	0.03155	12.9	-2.62
130	0.02771	13.7	-2.56
135	0.02442	14.4	-2.50
140	0.02158	15.2	-2.44
145	0.01913	16.0	-2.38
150	0.01700	16.8	-2.33

T (°C)	Material B(K) NA 4100		
	R(T) / R25	TF (%)	α (%/°C)
-55	109.5	8.0	-7.53
-50	75.44	6.9	-7.27
-45	52.64	6.0	-7.02
-40	37.19	5.1	-6.78
-35	26.59	4.3	-6.56
-30	19.22	3.7	-6.34
-25	14.05	3.1	-6.14
-20	10.37	2.5	-5.94
-15	7.730	2.1	-5.75
-10	5.817	1.6	-5.57
-5	4.417	1.3	-5.40
0	3.382	1.0	-5.23
5	2.611	0.7	-5.08
10	2.032	0.5	-4.92
15	1.593	0.3	-4.78
20	1.258	0.1	-4.64
25	1.0000	0.0	-4.51
30	0.8003	0.1	-4.38
35	0.6446	0.3	-4.25
40	0.5224	0.4	-4.14
45	0.4258	0.6	-4.02
50	0.3490	0.8	-3.91
55	0.2877	1.0	-3.81
60	0.2383	1.2	-3.71
65	0.1984	1.4	-3.61
70	0.1660	1.6	-3.51
75	0.1395	1.8	-3.42
80	0.1178	2.1	-3.34
85	0.09989	2.3	-3.25
90	0.08506	2.5	-3.17
95	0.07271	2.8	-3.09
100	0.06240	3.0	-3.02
105	0.05375	3.3	-2.94
110	0.04647	3.5	-2.87
115	0.04032	3.8	-2.81
120	0.03509	4.1	-2.74
125	0.03065	4.3	-2.68
130	0.02685	4.6	-2.61
135	0.02359	4.8	-2.55
140	0.02079	5.1	-2.50
145	0.01837	5.4	-2.44
150	0.01628	5.6	-2.39

T (°C)	Material B(K) NC 4080		
	R(T) / R25	TF (%)	α (%/°C)
-55	105.4	24.0	-7.45
-50	72.89	20.7	-7.20
-45	51.04	17.8	-6.95
-40	36.18	15.2	-6.72
-35	25.94	12.9	-6.50
-30	18.81	10.9	-6.29
-25	13.78	9.1	-6.08
-20	10.20	7.5	-5.89
-15	7.621	6.1	-5.71
-10	5.748	4.9	-5.53
-5	4.373	3.8	-5.36
0	3.355	2.9	-5.20
5	2.595	2.1	-5.04
10	2.023	1.4	-4.89
15	1.588	0.9	-4.75
20	1.256	0.4	-4.61
25	1.0000	0.0	-4.48
30	0.8014	0.4	-4.35
35	0.6463	0.8	-4.23
40	0.5243	1.3	-4.11
45	0.4278	1.8	-4.00
50	0.3510	2.3	-3.89
55	0.2896	2.9	-3.79
60	0.2401	3.5	-3.69
65	0.2001	4.1	-3.59
70	0.1675	4.8	-3.50
75	0.1409	5.5	-3.41
80	0.1190	6.2	-3.32
85	0.1010	6.9	-3.24
90	0.08605	7.6	-3.16
95	0.07360	8.3	-3.08
100	0.06319	9.1	-3.01
105	0.05446	9.8	-2.94
110	0.04710	10.6	-2.87
115	0.04087	11.3	-2.80
120	0.03559	12.1	-2.73
125	0.03109	12.9	-2.67
130	0.02724	13.7	-2.61
135	0.02394	14.4	-2.55
140	0.02111	15.2	-2.49
145	0.01866	16.0	-2.44
150	0.01654	16.8	-2.38

T (°C)	Material B(K) NE 4100		
	R(T) / R25	TF (%)	α (%/°C)
-55	97.27	24.1	-7.2
-50	67.99	20.8	-7.0
-45	48.08	17.9	-6.8
-40	34.39	15.3	-6.5
-35	24.85	12.9	-6.3
-30	18.15	11.0	-6.1
-25	13.38	9.2	-6.0
-20	9.960	7.6	-5.8
-15	7.479	6.2	-5.6
-10	5.664	4.9	-5.4
-5	4.325	3.8	-5.3
0	3.328	2.9	-5.1
5	2.581	2.1	-5.0
10	2.016	1.4	-4.9
15	1.585	0.9	-4.7
20	1.255	0.4	-4.6
25	1.0000	0.0	-4.5
30	0.8017	0.4	-4.3
35	0.6466	0.8	-4.2
40	0.5245	1.3	-4.1
45	0.4278	1.8	-4.0
50	0.3508	2.3	-3.9
55	0.2891	2.9	-3.8
60	0.2394	3.5	-3.7
65	0.1992	4.2	-3.6
70	0.1666	4.8	-3.5
75	0.1399	5.5	-3.4
80	0.11794	6.2	-3.4
85	0.09987	6.9	-3.3
90	0.08491	7.6	-3.2
95	0.07246	8.4	-3.1
100	0.06207	9.1	-3.1
105	0.05336	9.9	-3.0
110	0.04604	10.6	-2.9
115	0.03985	11.4	-2.8
120	0.03461	12.2	-2.8
125	0.03015	12.9	-2.7
130	0.02635	13.7	-2.7
135	0.02309	14.5	-2.6
140	0.0203	15.3	-2.5
145	0.01789	16.1	-2.5
150	0.01581	16.8	-2.4

T (°C)	Material B(K) N5 4160		
	R(T) / R25	TF (%)	α (%/°C)
-55	115.8	16.3	-7.52
-50	79.72	14.1	-7.28
-45	55.54	12.1	-7.04
-40	39.15	10.4	-6.82
-35	27.91	8.8	-6.61
-30	20.11	7.4	-6.40
-25	14.64	6.2	-6.20
-20	10.77	5.1	-6.01
-15	7.996	4.2	-5.83
-10	5.991	3.3	-5.65
-5	4.529	2.6	-5.48
0	3.454	2.0	-5.31
5	2.655	1.4	-5.16
10	2.057	1.0	-5.00
15	1.606	0.6	-4.86
20	1.263	0.3	-4.72
25	1.0000	0.0	-4.58
30	0.7973	0.3	-4.45
35	0.6398	0.5	-4.32
40	0.5167	0.9	-4.20
45	0.4198	1.2	-4.09
50	0.3430	1.6	-3.97
55	0.2819	2.0	-3.86
60	0.2329	2.4	-3.76
65	0.1934	2.8	-3.66
70	0.1614	3.3	-3.56
75	0.1354	3.7	-3.46
80	0.1141	4.2	-3.37
85	0.09658	4.7	-3.29
90	0.08211	5.2	-3.20
95	0.07010	5.7	-3.12
100	0.06009	6.2	-3.04
105	0.05171	6.7	-2.96
110	0.04467	7.2	-2.89
115	0.03872	7.7	-2.82
120	0.03369	8.2	-2.75
125	0.02941	8.8	-2.68
130	0.02576	9.3	-2.62
135	0.02263	9.8	-2.55
140	0.01995	10.3	-2.49
145	0.01763	10.9	-2.44
150	0.01563	11.4	-2.38



TABLES OF RESISTANCE VS TEMPERATURE



T (°C)	Material B(K)		
	R(T) / R25	TF (%)	α (%/°C)
-55	121.4	24.8	-7.56
-50	83.35	21.5	-7.32
-45	57.92	18.4	-7.09
-40	40.72	15.8	-6.87
-35	28.95	13.4	-6.66
-30	20.80	11.3	-6.45
-25	15.10	9.4	-6.26
-20	11.07	7.8	-6.07
-15	8.197	6.3	-5.89
-10	6.123	5.1	-5.71
-5	4.615	4.0	-5.54
0	3.508	3.0	-5.38
5	2.688	2.2	-5.22
10	2.076	1.5	-5.07
15	1.616	0.9	-4.92
20	1.267	0.4	-4.78
25	1.0000	0.0	-4.64
30	0.7949	0.4	-4.51
35	0.6359	0.8	-4.38
40	0.5120	1.3	-4.26
45	0.4148	1.8	-4.14
50	0.3379	2.4	-4.03
55	0.2769	3.0	-3.92
60	0.2281	3.6	-3.81
65	0.1890	4.3	-3.71
70	0.1573	5.0	-3.61
75	0.1316	5.7	-3.52
80	0.1106	6.4	-3.42
85	0.09337	7.1	-3.34
90	0.07918	7.9	-3.25
95	0.06743	8.6	-3.17
100	0.05766	9.4	-3.09
105	0.04950	10.2	-3.01
110	0.04266	10.9	-2.93
115	0.03691	11.7	-2.86
120	0.03204	12.5	-2.79
125	0.02791	13.3	-2.72
130	0.02439	14.1	-2.66
135	0.02139	14.9	-2.59
140	0.01881	15.7	-2.53
145	0.01660	16.5	-2.47
150	0.01469	17.3	-2.42

T (°C)	Material B(K)		
	R(T) / R25	TF (%)	α (%/°C)
-55	123.40	8.3	-7.68
-50	84.33	7.2	-7.42
-45	58.39	6.2	-7.17
-40	40.93	5.3	-6.93
-35	29.04	4.5	-6.71
-30	20.83	3.8	-6.49
-25	15.11	3.2	-6.29
-20	11.07	2.6	-6.09
-15	8.190	2.1	-5.90
-10	6.117	1.7	-5.72
-5	4.610	1.3	-5.54
0	3.505	1.0	-5.38
5	2.686	0.7	-5.22
10	2.075	0.5	-5.07
15	1.615	0.3	-4.92
20	1.267	0.1	-4.78
25	1.0000	0.0	-4.64
30	0.7949	0.1	-4.51
35	0.6359	0.3	-4.39
40	0.5119	0.4	-4.27
45	0.4145	0.6	-4.15
50	0.3376	0.8	-4.04
55	0.2764	1.0	-3.93
60	0.2276	1.2	-3.83
65	0.1883	1.4	-3.73
70	0.1566	1.7	-3.63
75	0.1308	1.9	-3.54
80	0.1098	2.1	-3.45
85	0.09257	2.4	-3.37
90	0.07836	2.6	-3.28
95	0.06661	2.9	-3.20
100	0.05685	3.1	-3.13
105	0.04870	3.4	-3.05
110	0.04188	3.7	-2.98
115	0.03614	3.9	-2.91
120	0.03129	4.2	-2.84
125	0.02719	4.5	-2.78
130	0.02370	4.7	-2.71
135	0.02072	5.0	-2.65
140	0.01817	5.3	-2.59
145	0.01598	5.5	-2.54
150	0.01409	5.8	-2.48

T (°C)	Material B(K)		
	R(T) / R25	TF (%)	α (%/°C)
-55	98.04	25.3	-6.87
-50	69.53	21.9	-6.70
-45	49.73	18.8	-6.53
-40	35.87	16.1	-6.37
-35	26.08	13.6	-6.22
-30	19.12	11.5	-6.07
-25	14.12	9.6	-5.92
-20	10.51	7.9	-5.78
-15	7.877	6.5	-5.64
-10	5.947	5.2	-5.50
-5	4.521	4.0	-5.37
0	3.460	3.1	-5.24
5	2.666	2.2	-5.11
10	2.067	1.5	-4.99
15	1.613	0.9	-4.87
20	1.266	0.4	-4.75
25	1.0000	0.0	-4.63
30	0.7944	0.4	-4.52
35	0.6347	0.8	-4.41
40	0.5099	1.3	-4.30
45	0.4119	1.9	-4.20
50	0.3344	2.4	-4.09
55	0.2730	3.1	-3.99
60	0.2239	3.7	-3.90
65	0.1846	4.4	-3.80
70	0.1529	5.1	-3.71
75	0.1272	5.8	-3.62
80	0.1063	6.5	-3.53
85	0.08927	7.2	-3.44
90	0.07526	8.0	-3.36
95	0.06372	8.8	-3.28
100	0.05477	9.6	-3.20
105	0.04622	10.4	-3.13
110	0.03960	11.2	-3.05
115	0.03405	12.0	-2.98
120	0.02938	12.8	-2.91
125	0.02545	13.6	-2.84
130	0.02211	14.4	-2.77
135	0.01928	15.2	-2.71
140	0.01686	16.0	-2.64
145	0.01479	16.8	-2.58
150	0.01302	17.7	-2.52

T (°C)	Material B(K)		
	R(T) / R25	TF (%)	α (%/°C)
-55	99.06	8.3	-7.09
-50	69.60	7.2	-6.88
-45	49.42	6.2	-6.68
-40	35.45	5.3	-6.49
-35	25.67	4.5	-6.30
-30	18.77	3.8	-6.13
-25	13.84	3.2	-5.96
-20	10.29	2.6	-5.79
-15	7.719	2.1	-5.64
-10	5.834	1.7	-5.49
-5	4.442	1.3	-5.34
0	3.407	1.0	-5.20
5	2.632	0.7	-5.07
10	2.047	0.5	-4.94
15	1.602	0.3	-4.81
20	1.262	0.1	-4.69
25	1.0000	0.0	-4.57
30	0.7971	0.1	-4.46
35	0.6389	0.3	-4.35
40	0.5149	0.4	-4.24
45	0.4172	0.6	-4.14
50	0.3397	0.8	-4.04
55	0.2780	1.0	-3.95
60	0.2286	1.2	-3.85
65	0.1888	1.4	-3.76
70	0.1567	1.7	-3.68
75	0.1306	1.9	-3.59
80	0.1093	2.1	-3.51
85	0.09179	2.4	-3.43
90	0.07743	2.6	-3.36
95	0.06556	2.9	-3.28
100	0.05571	3.2	-3.21
105	0.04752	3.4	-3.14
110	0.04067	3.7	-3.07
115	0.03492	3.9	-3.01
120	0.03008	4.2	-2.94
125	0.02600	4.5	-2.88
130	0.02254	4.7	-2.82
135	0.01960	5.0	-2.76
140	0.01709	5.3	-2.71
145	0.01495	5.5	-2.65
150	0.01311	5.8	-2.60

T (°C)	Material B(K)		
	R(T) / R25	TF (%)	α (%/°C)
-55	113.90	25.9	-7.13
-50	79.71	22.4	-6.95
-45	56.30	19.2	-6.77
-40	40.13	16.4	-6.60
-35	28.85	14.0	-6.44
-30	20.92	11.8	-6.28
-25	15.29	9.8	-6.12
-20	11.27	8.1	-5.97
-15	8.368	6.6	-5.82
-10	6.261	5.3	-5.68
-5	4.719	4.1	-5.53
0	3.583	3.1	-5.40
5	2.739	2.3	-5.26
10	2.108	1.5	-5.13
15	1.634	0.9	-5.00
20	1.274	0.4	-4.88
25	1.0000	0.0	-4.75
30	0.7897	0.4	-4.64
35	0.6273	0.9	-4.52
40	0.5012	1.4	-4.41
45	0.4028	1.9	-4.30
50	0.3255	2.5	-4.19
55	0.2644	3.1	-4.09
60	0.2159	3.8	-3.98
65	0.1772	4.5	-3.89
70	0.1462	5.2	-3.79
75	0.1212	5.9	-3.70
80	0.1009	6.7	-3.60
85	0.08440	7.4	-3.52
90	0.07092	8.2	-3.43
95	0.05984	9.0	-3.35
100	0.05071	9.8	-3.26
105	0.04314	10.6	-3.19
110	0.03685	11.4	-3.11
115	0.03160	12.2	-3.03
120	0.02719	13.1	-2.96
125	0.02349	13.9	-2.89
130	0.02036	14.7	-2.82
135	0.01770	15.6	-2.76
140	0.01545	16.4	-2.69
145	0.01352	17.2	-2.63
150	0.01187	18.1	-2.57

T (°C)	Material B(K)		
	R(T) / R25	TF (%)	α (%/°C)
-55	110.80	8.6	-7.24
-50	77.24	7.4	-7.03
-45	54.44	6.4	-6.83
-40	38.76	5.5	-6.63
-35	27.87	4.6	-6.45
-30	20.22	3.9	-6.27
-25	14.81	3.3	-6.10
-20	10.94	2.7	-5.93
-15	8.144	2.2	-5.78
-10	6.112	1.8	-5.62
-5	4.623	1.4	-5.48
0	3.522	1.0	-5.34
5	2.702	0.8	-5.20
10	2.087	0.5	-5.07
15	1.623	0.3	-4.94
20	1.270	0.1	-4.82
25	1.0000	0.0	-4.70
30	0.7920	0.1	-4.59
35	0.6308	0.3	-4.47
40	0.5052	0.5	-4.37
45	0.4068	0.6	-4.26
50	0.3292	0.8	-4.16
55	0.2678	1.0	-4.07
60	0.2189	1.3	-3.97
65	0.1797	1.5	-3.88
70	0.1482	1.7	-3.79
75	0.1228	2.0	-3.71
80	0.1022	2.2	-3.63
85	0.08536	2.5	-3.55
90	0.07159	2.7	-3.47
95	0.06028	3.0	-3.39
100	0.05095	3.2	-3.32
105	0.04322	3.5	-3.25
110	0.03679	3.8	-3.18
115	0.03142	4.1	-3.11
120	0.02693	4.3	-3.05
125	0.02315	4.6	-2.98
130	0.01997	4.9	-2.92
135	0.01728	5.2	-2.86
140	0.01499	5.4	-2.80
145	0.01304	5.7	-2.75
150	0.01138	6.0	-2.69



The Important Information/Disclaimer is incorporated in these specifications by reference and should be reviewed in full before placing any order.

TABLES OF RESISTANCE VS TEMPERATURE



T (°C)	Material B(K) RC 4340		
	R(T) / R25	TF (%)	α (%/°C)
-55	105.70	25.5	-7.15
-50	74.01	22.1	-6.95
-45	52.37	19.0	-6.75
-40	37.43	16.2	-6.56
-35	27.01	13.8	-6.38
-30	19.66	11.6	-6.20
-25	14.44	9.7	-6.04
-20	10.70	8.0	-5.87
-15	7.990	6.5	-5.72
-10	6.013	5.2	-5.57
-5	4.559	4.1	-5.42
0	3.482	3.1	-5.29
5	2.678	2.2	-5.15
10	2.074	1.5	-5.02
15	1.616	0.9	-4.90
20	1.267	0.4	-4.77
25	1.0000	0.0	-4.66
30	0.7936	0.4	-4.54
35	0.6334	0.8	-4.43
40	0.5083	1.3	-4.33
45	0.4100	1.9	-4.23
50	0.3325	2.5	-4.13
55	0.2709	3.1	-4.03
60	0.2218	3.7	-3.94
65	0.1825	4.4	-3.85
70	0.1508	5.1	-3.76
75	0.1251	5.8	-3.67
80	0.1043	6.6	-3.59
85	0.08727	7.3	-3.51
90	0.07332	8.1	-3.43
95	0.06184	8.9	-3.36
100	0.05235	9.7	-3.29
105	0.04448	10.5	-3.22
110	0.03793	11.3	-3.15
115	0.03245	12.1	-3.08
120	0.02785	12.9	-3.01
125	0.02399	13.7	-2.95
130	0.02072	14.5	-2.89
135	0.01796	15.4	-2.83
140	0.01561	16.2	-2.77
145	0.01360	17.0	-2.72
150	0.01189	17.8	-2.66

T (°C)	Material B(K) T 4630		
	R(T) / R25	TF (%)	α (%/°C)
-55	137.10	27.2	-7.33
-50	94.94	23.5	-7.15
-45	66.35	20.2	-6.98
-40	46.78	17.3	-6.82
-35	33.25	14.7	-6.66
-30	23.84	12.4	-6.50
-25	17.23	10.3	-6.35
-20	12.54	8.5	-6.20
-15	9.206	6.9	-6.05
-10	6.807	5.6	-5.91
-5	5.070	4.3	-5.77
0	3.803	3.3	-5.63
5	2.873	2.4	-5.50
10	2.185	1.6	-5.36
15	1.673	1.0	-5.23
20	1.289	0.4	-5.11
25	1.0000	0.0	-4.99
30	0.7805	0.4	-4.86
35	0.6129	0.9	-4.75
40	0.4841	1.4	-4.63
45	0.3847	2.0	-4.52
50	0.3074	2.6	-4.41
55	0.2470	3.3	-4.30
60	0.1996	4.0	-4.19
65	0.1621	4.7	-4.09
70	0.1323	5.4	-3.99
75	0.1086	6.2	-3.89
80	0.08951	7.0	-3.80
85	0.07416	7.8	-3.71
90	0.06172	8.6	-3.62
95	0.05160	9.5	-3.53
100	0.04333	10.3	-3.44
105	0.03655	11.2	-3.36
110	0.03095	12.0	-3.28
115	0.02632	12.9	-3.20
120	0.02246	13.7	-3.12
125	0.01925	14.6	-3.05
130	0.01656	15.5	-2.97
135	0.01429	16.4	-2.90
140	0.01238	17.3	-2.83
145	0.01076	18.1	-2.77
150	0.009383	19.0	-2.70

T (°C)	Material B(K) U 4840		
	R(T) / R25	TF (%)	α (%/°C)
-55	173.70	28.5	-7.69
-50	118.20	24.6	-7.50
-45	81.18	21.2	-7.32
-40	56.26	18.1	-7.15
-35	39.34	15.4	-6.98
-30	27.75	12.9	-6.82
-25	19.74	10.8	-6.66
-20	14.15	8.9	-6.50
-15	10.23	7.3	-6.34
-10	7.457	5.8	-6.19
-5	5.476	4.5	-6.04
0	4.051	3.4	-5.90
5	3.020	2.5	-5.76
10	2.267	1.7	-5.62
15	1.714	1.0	-5.48
20	1.305	0.5	-5.35
25	1.0000	0.0	-5.22
30	0.7715	0.4	-5.09
35	0.5991	0.9	-4.97
40	0.4681	1.5	-4.84
45	0.3680	2.1	-4.72
50	0.2911	2.8	-4.61
55	0.2316	3.4	-4.49
60	0.1853	4.2	-4.38
65	0.1491	4.9	-4.28
70	0.1206	5.7	-4.17
75	0.09812	6.5	-4.07
80	0.08022	7.3	-3.97
85	0.06591	8.2	-3.87
90	0.05442	9.0	-3.77
95	0.04515	9.9	-3.68
100	0.03763	10.8	-3.59
105	0.03150	11.7	-3.50
110	0.02649	12.6	-3.42
115	0.02237	13.5	-3.33
120	0.01897	14.4	-3.25
125	0.01615	15.3	-3.17
130	0.01380	16.2	-3.10
135	0.01184	17.1	-3.02
140	0.01020	18.0	-2.95
145	0.008814	19.0	-2.88
150	0.007643	19.9	-2.81

T (°C)	Material B(K) S 4520		
	R(T) / R25	TF (%)	α (%/°C)
-55	126.10	26.6	-7.25
-50	87.75	23.0	-7.07
-45	61.60	19.8	-6.90
-40	43.63	16.9	-6.73
-35	31.17	14.3	-6.56
-30	22.46	12.1	-6.40
-25	16.31	10.1	-6.25
-20	11.94	8.3	-6.10
-15	8.809	6.8	-5.95
-10	6.549	5.4	-5.80
-5	4.904	4.2	-5.66
0	3.699	3.2	-5.52
5	2.810	2.3	-5.39
10	2.149	1.6	-5.26
15	1.654	1.0	-5.13
20	1.282	0.4	-5.00
25	1.0000	0.0	-4.88
30	0.7848	0.4	-4.76
35	0.6196	0.9	-4.64
40	0.4921	1.4	-4.52
45	0.3931	2.0	-4.41
50	0.3158	2.6	-4.30
55	0.2551	3.2	-4.20
60	0.2072	3.9	-4.09
65	0.1691	4.6	-3.99
70	0.1387	5.3	-3.89
75	0.1144	6.1	-3.80
80	0.0948	6.8	-3.71
85	0.0789	7.6	-3.61
90	0.06594	8.4	-3.53
95	0.05538	9.2	-3.44
100	0.04671	10.1	-3.36
105	0.03956	10.9	-3.28
110	0.03364	11.7	-3.20
115	0.02872	12.6	-3.12
120	0.02461	13.4	-3.04
125	0.02117	14.3	-2.97
130	0.01827	15.1	-2.90
135	0.01583	16.0	-2.83
140	0.01376	16.8	-2.77
145	0.01200	17.7	-2.70
150	0.01050	18.6	-2.64

T (°C)	Material B(K) SC 4500		
	R(T) / R25	TF (%)	α (%/°C)
-55	129.80	26.5	-7.51
-50	89.31	22.9	-7.29
-45	62.15	19.7	-7.07
-40	43.72	16.8	-6.87
-35	31.07	14.3	-6.68
-30	22.29	12.0	-6.49
-25	16.15	10.0	-6.31
-20	11.80	8.3	-6.14
-15	8.703	6.8	-5.97
-10	6.470	5.4	-5.81
-5	4.849	4.2	-5.66
0	3.662	3.2	-5.51
5	2.786	2.3	-5.36
10	2.135	1.6	-5.23
15	1.647	0.9	-5.09
20	1.279	0.4	-4.96
25	1.0000	0.0	-4.84
30	0.7865	0.4	-4.72
35	0.6223	0.9	-4.60
40	0.4953	1.4	-4.49
45	0.3963	2.0	-4.38
50	0.3189	2.6	-4.28
55	0.2579	3.2	-4.18
60	0.2096	3.9	-4.08
65	0.1712	4.6	-3.99
70	0.1405	5.3	-3.89
75	0.1159	6.0	-3.80
80	0.09595	6.8	-3.72
85	0.07980	7.6	-3.63
90	0.06664	8.4	-3.55
95	0.05588	9.2	-3.47
100	0.04704	10.0	-3.40
105	0.03975	10.8	-3.32
110	0.03371	11.7	-3.25
115	0.02869	12.5	-3.18
120	0.02450	13.4	-3.12
125	0.02100	14.2	-3.05
130	0.01805	15.1	-2.99
135	0.01557	15.9	-2.92
140	0.01347	16.8	-2.86
145	0.01169	17.6	-2.80
150	0.01017	18.5	-2.75



IDENTIFICATION – TRACEABILITY



On the packaging of all shipped thermistors, you will find a bar code label.

This label gives systematic information on the type of product, part number, lot number, manufacturing date and quantity. An example is given below:

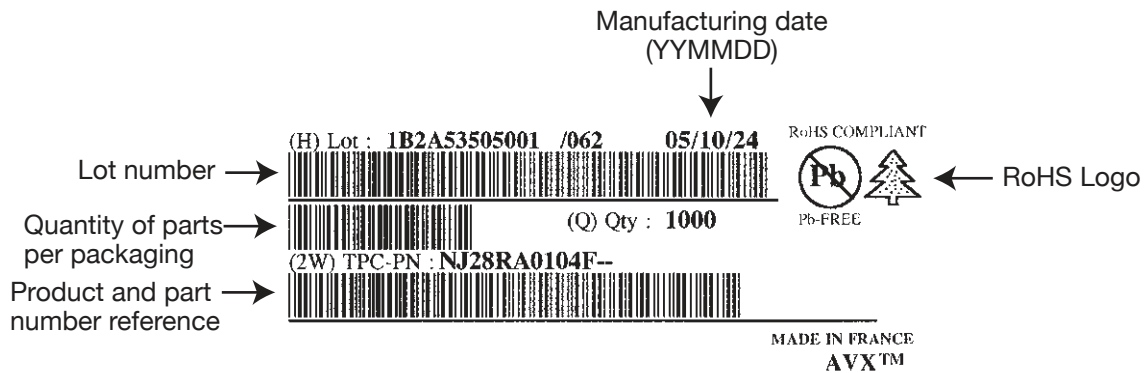

This information allows complete traceability of the entire manufacturing process, from raw materials to final inspection. This is extremely useful for any information request, customer complaint or product return.

FOLLOW US:

VISIT US AT



North America

Tel: +1 864-967-2150

Europe

Tel: +44 1276-697000

Asia

Tel: +65 6286-7555

Central America

Tel: +55 11-46881960

Japan

Tel: +81 740-321250