

AV3,AVM3/AVT3,AVL3

NAIS

NEW SUBMINIATURE SWITCHES WITH HIGH PRECISION

FS•FS-T (AV) SWITCHES



FS



FS-T

FEATURES

- New additions: FS-T Cross-line terminal types Gold-clad double layer types exclusively for low-level circuits
- Consistent quality and high precision through sophisticated automatic fabrication system —O.P.: 8.4 ± 0.3 mm $.331 \pm .012$ inch (O.P.of conventional subminiature switches: 8.4 ± 0.5 $.331 \pm .020$)
- Flux-resistant construction with integrally molded terminals
- Solder terminal; Self-standing, internationally common pitch, right angle, left angle terminals for PC board; Quick connect .110 terminals for easy mounting
- Insulation guard available for safety mounting

- 2 lever pivot positions available for applications where low operating force is required
- UL/CSA/VDE/SEMKO approved (As for gold-clad double layer, VDE and SEMKO are not approved)

TYPICAL APPLICATIONS

- Communication equipment
- Vending machines
- Security systems
- Data systems
- Medical equipment
- Cassette tape recorders
- VCR

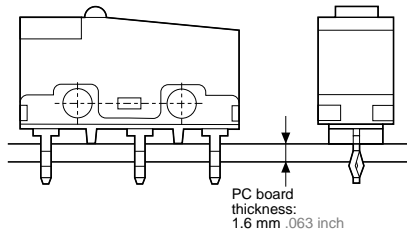

CONSTRUCTION (Example: AV3/AVM3 type)

Standard version

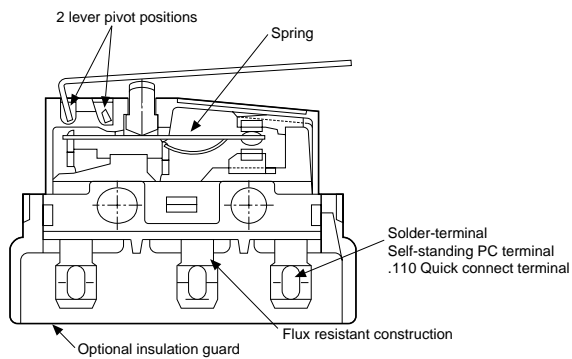

Long life version

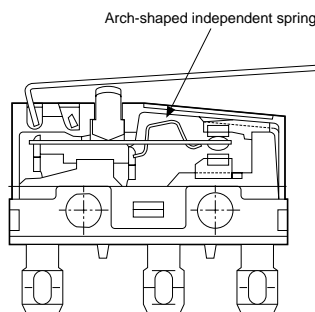

SCHEMATIC

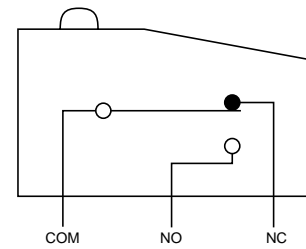

Remark: As for FS-T switches, the terminals are the different shape.

AV3,AVM3/AVT3,AVL3

ORDERING INFORMATION

1.FS switches

Ex. AV 3 2 0 2

Type of switch	Version	Terminals	Actuators	Operating force by pin plunger, max.	Lever position	Contacts
FS•FS-T switch	3: Standard M3: Long life	1: Self-standing solder terminal with guard 2: Self-standing solder terminal without guard 3: Self-standing solder terminal with opposite side guard 4: Self-standing PC terminal (5: Internationally common pitch PC terminal) (6: Right angle terminal) (7: Left angle terminal) 8: .110 Quick-connect terminal	0: Pin plunger 1: Short hinge lever 2: Hinge lever 3: Long hinge lever 4: Simulated roller lever 5: Roller lever	Standard version: 0: 0.25 N {25 gf} 2: 0.49 N {50 gf} 4: 0.98 N {100 gf} Long life version: 5: 1.47 N {150 gf}	Nil: Standard [11: forward]	Nil: Standard type 61: Gold-clad triple layer 64: Gold-clad double layer type exclusively for low-level circuits

2.FS-T switches

Ex. AV T3 2 0 2

Type of switch	Version	Terminals	Actuators	Operating force by pin plunger, max.	Lever position	Contacts
FS•FS-T switch	T3: Standard L3: Long life	2: Solder terminal 4: PC terminal 8: .110 Quick-connect terminal	0: Pin plunger 1: Short hinge lever 2: Hinge lever 3: Long hinge lever 4: Simulated roller lever 5: Roller lever	Standard version: 0: 0.25 N {25 gf} 2: 0.49 N {50 gf} 4: 0.98 N {100 gf} Long life version: 5: 1.47 N {150 gf}	Nil: Standard [11: forward]	Nil: Standard type (Not applicable to 25 gf type) 61: Gold-clad triple layer 64: Gold-clad double layer type exclusively for low-level circuits

APPLICABLE CURRENT RANGE

Type	Contact	Rating				O.F.			
		1mA	100mA	3A	5A	0.25 N {25 gf}	0.49 N {50 gf}	0.98 N {100 gf}	1.47 N {150 gf}
Standard version	Silver alloy contact						●	●	
	Gold-clad triple layer contact type					●	●	●	
	Gold-clad double layer contact type					●	●	●	
Long life version	Silver alloy contact								●
	Gold-clad triple layer contact type								●
	Gold-clad double layer contact type								●

Remark: For high capacity contact rating up to 10.1 A, please refer to PS (AVM3□□□P) switches catalog.

AV3,AVM3/AVT3,AVL3

PRODUCT TYPES

1.FS switches (In-line terminal type)

Standard type

	Actuator	Operating force, Max.	Part No.					
			Self-standing solder terminal			Self-standing PC terminal	.110 Quick-connect terminal	
			Without guard	With guard	With opposite side guard			
Silver alloy contact type	Pin plunger	0.49 N {50 gf}	AV3202	AV3102	AV3302	AV3402	AV3802	
		0.98 N {100 gf}	AV3204	AV3104	AV3304	AV3404	AV3804	
	Short hinge lever	0.20 N {20 gf}	AV3212	AV3112	AV3312	AV3412	AV3812	
		0.39 N {40 gf}	AV3214	AV3114	AV3314	AV3414	AV3814	
	Hinge lever	0.16 N {16 gf}	AV3222	AV3122	AV3322	AV3422	AV3822	
		0.34 N {35 gf}	AV3224	AV3124	AV3324	AV3424	AV3824	
	Long hinge lever	0.12 N {12 gf}	AV3232	AV3132	AV3332	AV3432	AV3832	
		0.25 N {25 gf}	AV3234	AV3134	AV3334	AV3434	AV3834	
	Simulated roller lever	0.16 N {16 gf}	AV3242	AV3142	AV3342	AV3442	AV3842	
		0.34 N {35 gf}	AV3244	AV3144	AV3344	AV3444	AV3844	
	Roller lever	0.20 N {20 gf}	AV3252	AV3152	AV3352	AV3452	AV3852	
		0.39 N {40 gf}	AV3254	AV3154	AV3354	AV3454	AV3854	
Gold-clad triple layer contact type	Pin plunger	0.25 N {25 gf}	AV320061	AV310061	AV330061	AV340061	AV380061	
		0.49 N {50 gf}	AV320261	AV310261	AV330261	AV340261	AV380261	
		0.98 N {100 gf}	AV320461	AV310461	AV330461	AV340461	AV380461	
	Short hinge lever	0.098 N {10 gf}	AV321061	AV311061	AV331061	AV341061	AV381061	
		0.20 N {20 gf}	AV321261	AV311261	AV331261	AV341261	AV381261	
		0.39 N {40 gf}	AV321461	AV311461	AV331461	AV341461	AV381461	
	Hinge lever	0.078 N {8 gf}	AV322061	AV312061	AV332061	AV342061	AV382061	
		0.16 N {16 gf}	AV322261	AV312261	AV332261	AV342261	AV382261	
		0.34 N {35 gf}	AV322461	AV312461	AV332461	AV342461	AV382461	
	Long hinge lever	0.12 N {12 gf}	AV323261	AV313261	AV333261	AV343261	AV383261	
		0.25 N {25 gf}	AV323461	AV313461	AV333461	AV343461	AV383461	
	Simulated roller lever	0.16 N {16 gf}	AV324261	AV314261	AV334261	AV344261	AV384261	
		0.34 N {35 gf}	AV324461	AV314461	AV334461	AV344461	AV384461	
	Roller lever	0.20 N {20 gf}	AV325261	AV315261	AV335261	AV345261	AV385261	
		0.39 N {40 gf}	AV325461	AV315461	AV335461	AV345461	AV385461	
	Gold-clad double layer type exclusively for low-level circuits	Pin plunger	0.25 N {25 gf}	AV320064	AV310064	AV330064	AV340064	AV380064
			0.49 N {50 gf}	AV320264	AV310264	AV330264	AV340264	AV380264
			0.98 N {100 gf}	AV320464	AV310464	AV330464	AV340464	AV380464
Short hinge lever		0.098 N {10 gf}	AV321064	AV311064	AV331064	AV341064	AV381064	
		0.20 N {20 gf}	AV321264	AV311264	AV331264	AV341264	AV381264	
		0.39 N {40 gf}	AV321464	AV311464	AV331464	AV341464	AV381464	
Hinge lever		0.078 N {8 gf}	AV322064	AV312064	AV332064	AV342064	AV382064	
		0.16 N {16 gf}	AV322264	AV312264	AV332264	AV342264	AV382264	
		0.34 N {35 gf}	AV322464	AV312464	AV332464	AV342464	AV382464	
Long hinge lever		0.12 N {12 gf}	AV323264	AV313264	AV333264	AV343264	AV383264	
		0.25 N {25 gf}	AV323464	AV313464	AV333464	AV343464	AV383464	
Simulated roller lever		0.16 N {16 gf}	AV324264	AV314264	AV334264	AV344264	AV384264	
		0.34 N {35 gf}	AV324464	AV314464	AV334464	AV344464	AV384464	
Roller lever		0.20 N {20 gf}	AV325264	AV315264	AV335264	AV345264	AV385264	
		0.39 N {40 gf}	AV325464	AV315464	AV335464	AV345464	AV385464	

Remark: When ordering, please refer to "Remarks" of ordering information.

AV3,AVM3/AVT3,AVL3

2.FS-T switches (Cross-line terminal type) Standard type

	Actuator	Operating force, Max.	Part No.			
			Solder terminal without guard	PC terminal	.110 Quick-connect terminal	
Silver alloy contact type	Pin plunger	0.49 N {50 gf}	AVT3202	AVT3402	AVT3802	
		0.98 N {100 gf}	AVT3204	AVT3404	AVT3804	
	Short hinge lever	0.20 N {20 gf}	AVT3212	AVT3412	AVT3812	
		0.39 N {40 gf}	AVT3214	AVT3414	AVT3814	
	Hinge lever	0.16 N {16 gf}	AVT3222	AVT3422	AVT3822	
		0.34 N {35 gf}	AVT3224	AVT3424	AVT3824	
	Long hinge lever	0.12 N {12 gf}	AVT3232	AVT3432	AVT3832	
		0.25 N {25 gf}	AVT3234	AVT3434	AVT3834	
	Simulated roller lever	0.16 N {16 gf}	AVT3242	AVT3442	AVT3842	
		0.34 N {35 gf}	AVT3244	AVT3444	AVT3844	
	Roller lever	0.20 N {20 gf}	AVT3252	AVT3452	AVT3852	
		0.39 N {40 gf}	AVT3254	AVT3454	AVT3854	
Gold-clad triple layer contact type	Pin plunger	0.25 N {25 gf}	AVT320061	AVT340061	AVT380061	
		0.49 N {50 gf}	AVT320261	AVT340261	AVT380261	
		0.98 N {100 gf}	AVT320461	AVT340461	AVT380461	
	Short hinge lever	0.098 N {10 gf}	AVT321061	AVT341061	AVT381061	
		0.20 N {20 gf}	AVT321261	AVT341261	AVT381261	
		0.39 N {40 gf}	AVT321461	AVT341461	AVT381461	
	Hinge lever	0.078 N {8 gf}	AVT322061	AVT342061	AVT382061	
		0.16 N {16 gf}	AVT322261	AVT342261	AVT382261	
		0.34 N {35 gf}	AVT322461	AVT342461	AVT382461	
	Long hinge lever	0.12 N {12 gf}	AVT323261	AVT343261	AVT383261	
		0.25 N {25 gf}	AVT323461	AVT343461	AVT383461	
	Simulated roller lever	0.16 N {16 gf}	AVT324261	AVT344261	AVT384261	
		0.34 N {35 gf}	AVT324461	AVT344461	AVT384461	
	Roller lever	0.20 N {20 gf}	AVT325261	AVT345261	AVT385261	
		0.39 N {40 gf}	AVT325461	AVT345461	AVT385461	
	Gold-clad double layer type exclusively for low-level circuits	Pin plunger	0.25 N {25 gf}	AVT320064	AVT340064	AVT380064
			0.49 N {50 gf}	AVT320264	AVT340264	AVT380264
			0.98 N {100 gf}	AVT320464	AVT340464	AVT380464
Short hinge lever		0.098 N {10 gf}	AVT321064	AVT341064	AVT381064	
		0.20 N {20 gf}	AVT321264	AVT341264	AVT381264	
		0.39 N {40 gf}	AVT321464	AVT341464	AVT381464	
Hinge lever		0.078 N {8 gf}	AVT322064	AVT342064	AVT382064	
		0.16 N {16 gf}	AVT322264	AVT342264	AVT382264	
		0.34 N {35 gf}	AVT322464	AVT342464	AVT382464	
Long hinge lever		0.12 N {12 gf}	AVT323264	AVT343264	AVT383264	
		0.25 N {25 gf}	AVT323464	AVT343464	AVT383464	
Simulated roller lever		0.16 N {16 gf}	AVT324264	AVT344264	AVT384264	
		0.34 N {35 gf}	AVT324464	AVT344464	AVT384464	
Roller lever		0.20 N {20 gf}	AVT325264	AVT345264	AVT385264	
		0.39 N {40 gf}	AVT325464	AVT345464	AVT385464	

AV3,AVM3/AVT3,AVL3

3.FS switches (In-line terminal type) Long life version

	Actuator	Operating force, Max.	Part No.				
			Self-standing solder terminal			Self-standing PC terminal	.110 Quick-connect terminal
			Without guard	With guard	With opposite side guard		
Silver alloy contact type	Pin plunger	1.47 N {150 gf}	AVM3205	AVM3105	AVM3305	AVM3405	AVM3805
	Short hinge lever	0.59 N {60 gf}	AVM3215	AVM3115	AVM3315	AVM3415	AVM3815
	Hinge lever	0.54 N {55 gf}	AVM3225	AVM3125	AVM3325	AVM3425	AVM3825
	Long hinge lever	0.44 N {45 gf}	AVM3235	AVM3135	AVM3335	AVM3435	AVM3835
	Simulated roller lever	0.54 N {55 gf}	AVM3245	AVM3145	AVM3345	AVM3445	AVM3845
	Roller lever	0.59 N {60 gf}	AVM3255	AVM3155	AVM3355	AVM3455	AVM3855
Gold-clad triple layer contact type	Pin plunger	1.47 N {150 gf}	AVM320561	AVM310561	AVM330561	AVM340561	AVM380561
	Short hinge lever	0.59 N {60 gf}	AVM321561	AVM311561	AVM331561	AVM341561	AVM381561
	Hinge lever	0.54 N {55 gf}	AVM322561	AVM312561	AVM332561	AVM342561	AVM382561
	Long hinge lever	0.44 N {45 gf}	AVM323561	AVM313561	AVM333561	AVM343561	AVM383561
	Simulated roller lever	0.54 N {55 gf}	AVM324561	AVM314561	AVM334561	AVM344561	AVM384561
	Roller lever	0.59 N {60 gf}	AVM325561	AVM315561	AVM335561	AVM345561	AVM385561
Gold-clad double layer type exclusively for low-level circuits	Pin plunger	1.47 N {150 gf}	AVM320564	AVM310564	AVM330564	AVM340564	AVM380564
	Short hinge lever	0.59 N {60 gf}	AVM321564	AVM311564	AVM331564	AVM341564	AVM381564
	Hinge lever	0.54 N {55 gf}	AVM322564	AVM312564	AVM332564	AVM342564	AVM382564
	Long hinge lever	0.44 N {45 gf}	AVM323564	AVM313564	AVM333564	AVM343564	AVM383564
	Simulated roller lever	0.54 N {55 gf}	AVM324564	AVM314564	AVM334564	AVM344564	AVM384564
	Roller lever	0.59 N {60 gf}	AVM325564	AVM315564	AVM335564	AVM345564	AVM385564

Remark: When ordering, please refer to "Remarks" of ordering information.

4.FS-T switches (Cross-line terminal type) Long life version

	Actuator	Operating force, Max.	Part No.		
			Solder terminal Without guard	PC terminal	.110 Quick-connect terminal
Silver alloy contact type	Pin plunger	1.47 N {150 gf}	AVL3205	AVL3405	AVL3805
	Short hinge lever	0.59 N {60 gf}	AVL3215	AVL3415	AVL3815
	Hinge lever	0.54 N {55 gf}	AVL3225	AVL3425	AVL3825
	Long hinge lever	0.44 N {45 gf}	AVL3235	AVL3435	AVL3835
	Simulated roller lever	0.54 N {55 gf}	AVL3245	AVL3445	AVL3845
	Roller lever	0.59 N {60 gf}	AVL3255	AVL3455	AVL3855
Gold-clad triple layer contact type	Pin plunger	1.47 N {150 gf}	AVL320561	AVL340561	AVL380561
	Short hinge lever	0.59 N {60 gf}	AVL321561	AVL341561	AVL381561
	Hinge lever	0.54 N {55 gf}	AVL322561	AVL342561	AVL382561
	Long hinge lever	0.44 N {45 gf}	AVL323561	AVL343561	AVL383561
	Simulated roller lever	0.54 N {55 gf}	AVL324561	AVL344561	AVL384561
	Roller lever	0.59 N {60 gf}	AVL325561	AVL345561	AVL385561
Gold-clad double layer type exclusively for low-level circuits	Pin plunger	1.47 N {150 gf}	AVL320564	AVL340564	AVL380564
	Short hinge lever	0.59 N {60 gf}	AVL321564	AVL341564	AVL381564
	Hinge lever	0.54 N {55 gf}	AVL322564	AVL342564	AVL382564
	Long hinge lever	0.44 N {45 gf}	AVL323564	AVL343564	AVL383564
	Simulated roller lever	0.54 N {55 gf}	AVL324564	AVL344564	AVL384564
	Roller lever	0.59 N {60 gf}	AVL325564	AVL345564	AVL385564

Remark: When ordering, please refer to "Remarks" of ordering information.

AV3,AVM3/AVT3,AVL3

SPECIFICATIONS

1.Contact rating

Voltage	Standard version				Long life version			
	Silver alloy contact type		Gold-clad contact type		Silver alloy contact type		Gold-clad contact type	
	Resistive load ($\cos\phi \approx 1$)	Inductive load ($\cos\phi \approx 0.6-0.7$)	Triple layer Resistive load ($\cos\phi \approx 1$)	Double layer Resistive load ($\cos\phi \approx 1$)	Resistive load ($\cos\phi \approx 1$)	Inductive load ($\cos\phi \approx 0.6-0.7$)	Triple layer Resistive load ($\cos\phi \approx 1$)	Double layer Resistive load ($\cos\phi \approx 1$)
125V AC	3A	2A	0.1A	—	5A	3A	0.1A	—
250V AC	3A	2A	0.1A	—	5A	3A	0.1A	—
30V DC	3A	2A	0.1A	0.1A	5A	3A	0.1A	0.1A
125V DC	0.4A	0.05A	—	—	0.4A	0.05A	—	—

Remark: Time constant shall be less than 7 msec. for DC inductive loads.

2.Characteristics

	Standard version		Long life version	
	Silver alloy contact type	Gold-clad contact type	Silver alloy contact type	Gold-clad contact type
Electrical life at rated load (O.T.max.)	5×10^4 at 20 cpm	2×10^5 at 20 cpm	5×10^4 at 20 cpm	2×10^5 at 20 cpm
Mechanical life	5×10^5 at 60 cpm (O.T.max.)		3×10^7 (O.T.: Specified value) 10^7 (O.T.max.) at 60 cpm	
Insulation resistance	Min.100M Ω at 500V DC			
Dielectric strength				
Between non-continuous terminals	1,000 Vrms			
Between each terminal and other exposed metal parts	1,500 Vrms			
Between each terminal and ground	1,500 Vrms			
Vibration resistance (Pin plunger type)	10 to 55 Hz at single amplitude of 1.5mm (Contact opening: max.1 msec.)			
Shock resistance (Pin plunger type) (Contact opening: less than 1 msec.)	294 m/s ² {30 G} min. (O.F. 0.98 N {100 gf}) 147 m/s ² {15 G} min. (O.F. 0.49 N {50 gf})	294 m/s ² {30 G} min. (O.F. 0.98 N {100 gf}) 147 m/s ² {15 G} min. (O.F. 0.49 N {50 gf}) 49 m/s ² {5 G} min. (O.F. 0.25 N {25 gf})	294 m/s ² {30 G} min.	
Contact resistance (Initial)	50 m Ω max. (by voltage drop 1 A 6 to 8V DC)	100 m Ω max. (by voltage drop 0.1 A 6 to 8V DC)	Au: 50 m Ω max. (by voltage drop 0.1 A 6 to 8V DC) Ag: 50 m Ω max. (by voltage drop 1 A 6 to 8V DC)	
Allowable operating speed	0.1 to 1,000 mm/sec.			
Max.operating cycle rate	300 cpm			
Ambient tempeprature	-25°C to +85°C -13°F to +185°F (no freezing below 0°C)			
Ambient humidity	Max.85% R.H.			
Unit weight	Approx.2g .07oz			

3.Operating characteristics

1) Pin plunger

4th digit number of Part No.	O.F.max.	R.F.min.	P.T.max.	M.D.max.	O.T.max.	O.P.
0	0.25N {25gf}	0.020N {2gf}	0.6mm .024inch	0.1mm .004inch	0.4mm .016inch	Distance from mounting holes: 8.4±0.3mm .331±.012inch Distance from stand-off: FS 11.8±0.4mm .465±.016inch FS-T 11.7±0.4mm .461±.016inch
2	0.49N {50gf}	0.074N {7.5gf}				
4	0.98N {100gf}	0.15N {15gf}				
5	1.47N {150gf}	0.20N {20gf}				

2) Short hinge lever

4th digit number of Part No.	O.F.max.	R.F.min.	P.T.max.	M.D.max.	O.T.max.	O.P.
0	0.098N {10gf}	0.004N {0.4gf}	2.5mm .098inch	0.5mm .020inch	0.8mm .031inch	Distance from mounting holes: 8.8±0.8mm .346±.031inch Distance from stand-off: FS 12.2±0.9mm .480±.035inch FS-T 12.1±0.9mm .476±.035inch
2	0.20N {20gf}	0.017N {1.7gf}				
4	0.39N {40gf}	0.034N {3.5gf}				
5	0.59N {60gf}	0.039N {4.0gf}				

AV3,AVM3/AVT3,AVL3

3) Hinge lever

4th digit number of Part No.	O.F.max.	R.F.min.	P.T.max.	M.D.max.	O.T.max.	O.P.
0	0.078N {8gf}	0.003N {0.35gf}	2.8mm .110inch	0.8mm .031inch	1.2mm .047inch	Distance from mounting holes: 8.8±0.8mm .346±.031inch Distance from stand-off: FS 12.2±0.9mm .480±.035inch FS-T 12.1±0.9mm .476±.035inch
2	0.16N {16gf}	0.015N {1.5gf}				
4	0.34N {35gf}	0.029N {3.0gf}				
5	0.54N {55gf}	0.034N {3.5gf}				

4) Long hinge lever

4th digit number of Part No.	O.F.max.	R.F.min.	P.T.max.	M.D.max.	O.T.max.	O.P.
0	—	—	3.5mm .138inch	1.0mm .039inch	1.6mm .063inch	Distance from mounting holes: 8.8±1.2mm .346±.047inch Distance from stand-off: FS 12.2±1.3mm .480±.051inch FS-T 12.1±1.3mm .476±.051inch
2	0.12N {12gf}	0.012N {1.2gf}				
4	0.25N {25gf}	0.025N {2.5gf}				
5	0.44N {45gf}	0.029N {3.0gf}				

5) Simulated roller lever

4th digit number of Part No.	O.F.max.	R.F.min.	P.T.max.	M.D.max.	O.T.max.	O.P.
0	—	—	2.8mm .110inch	0.8mm .031inch	1.2mm .047inch	Distance from mounting holes: 11.65±0.8mm .459±.031inch Distance from stand-off: FS 15.05±0.9mm .593±.035inch FS-T 14.95±0.9mm .589±.035inch
2	0.16N {16gf}	0.015N {1.5gf}				
4	0.34N {35gf}	0.029N {3.0gf}				
5	0.54N {55gf}	0.034N {3.5gf}				

6) Roller lever

4th digit number of Part No.	O.F.max.	R.F.min.	P.T.max.	M.D.max.	O.T.max.	O.P.
0	—	—	2.5mm .098inch	0.5mm .020inch	0.8mm .031inch	Distance from mounting holes: 14.5±0.8mm .571±.031inch Distance from stand-off: FS 17.9±0.9mm .705±.035inch FS-T 17.8±0.9mm .701±.035inch
2	0.20N {20gf}	0.017N {1.7gf}				
4	0.39N {40gf}	0.034N {3.5gf}				
5	0.59N {60gf}	0.039N {4.0gf}				

DIMENSIONS

mm inch General tolerance ±0.25 ±.010

1.FS switches (In-line terminal type)

1-(1) Self-standing solder terminal

Pin plunger

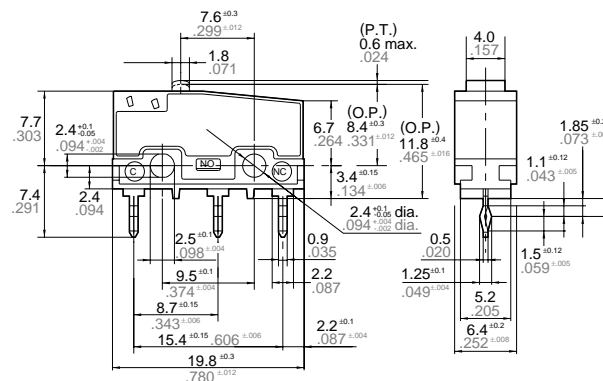

PC board pattern

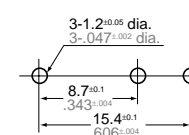

Pretravel, Max. mm inch	0.6 .024	
Movement differential, Max. mm inch	0.1 .004	
Overtravel, Min. mm inch	0.4 .016	
Operating position	Distance from mounting hole, mm inch	8.4±0.3 .331±.012
	Distance from standoff, mm inch	11.8±0.4 .465±.016

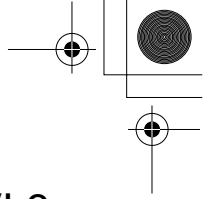

AV3,AVM3/AVT3,AVL3

mm inch General tolerance $\pm 0.25 \pm 0.10$

Short hinge lever

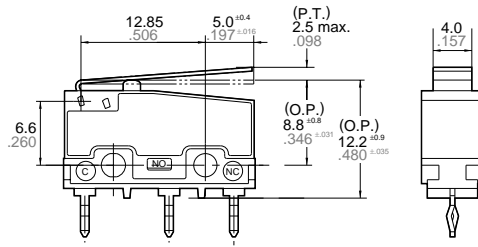

Pretravel, Max. mm inch	2.5 .098	
Movement differential, Max. mm inch	0.5 .020	
Overtravel, Min. mm inch	0.8 .031	
Operating position	Distance from mounting hole, mm inch	8.8±0.8 .346±.031
	Distance from standoff, mm inch	12.2±0.9 .480±.035

Hinge lever

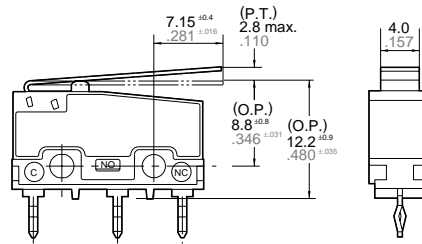

Pretravel, Max. mm inch	2.8 .110	
Movement differential, Max. mm inch	0.8 .031	
Overtravel, Min. mm inch	1.2 .047	
Operating position	Distance from mounting hole, mm inch	8.8±0.8 .346±.031
	Distance from standoff, mm inch	12.2±0.9 .480±.035

Long hinge lever

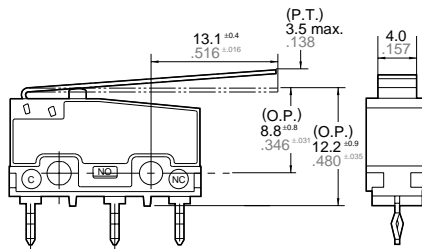

Pretravel, Max. mm inch	3.5 .138	
Movement differential, Max. mm inch	1.0 .039	
Overtravel, Min. mm inch	1.6 .063	
Operating position	Distance from mounting hole, mm inch	8.8±1.2 .346±.047
	Distance from standoff, mm inch	12.2±1.3 .480±.051

Simulated roller lever

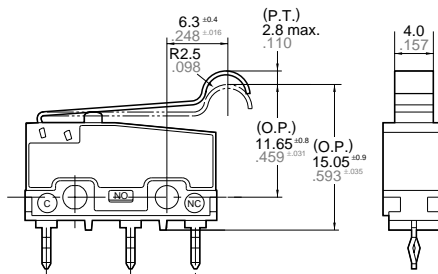

Pretravel, Max. mm inch	2.8 .110	
Movement differential, Max. mm inch	0.8 .031	
Overtravel, Min. mm inch	1.2 .047	
Operating position	Distance from mounting hole, mm inch	11.65±0.8 .459±.031
	Distance from standoff, mm inch	15.05±0.9 .593±.035

Roller lever

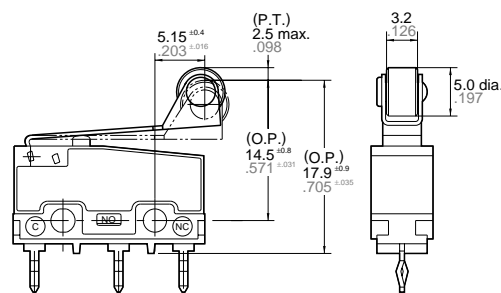
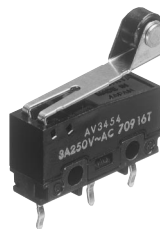

Pretravel, Max. mm inch	2.5 .098	
Movement differential, Max. mm inch	0.5 .020	
Overtravel, Min. mm inch	0.8 .031	
Operating position	Distance from mounting hole, mm inch	14.5±0.8 .571±.031
	Distance from standoff, mm inch	17.9±0.9 .705±.035

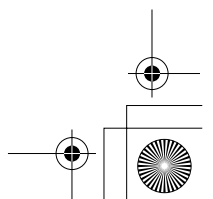
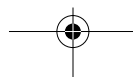
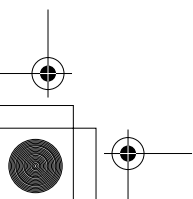

AV3,AVM3/AVT3,AVL3

1-(2) Self-standing solder terminal (without guard)

mm inch General tolerance $\pm 0.25 \pm 0.10$

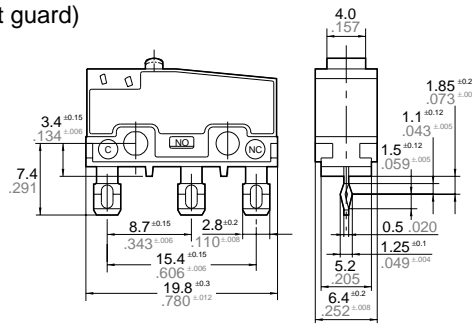

Dimensions other than drawn above is same as self-standing PC board terminal.

1-(3) Self-standing solder terminal (with guard)

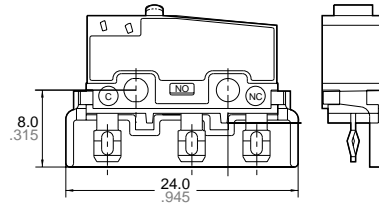

Dimensions other than drawn above is same as guardless type.

1-(4) Self-standing solder terminal (with opposite side guard)

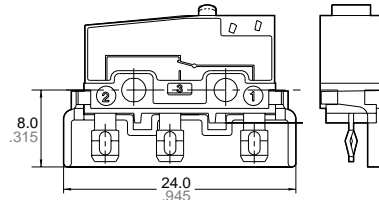

Dimensions other than drawn above is same as guardless type.

1-(5) .110 Quick-connect terminal

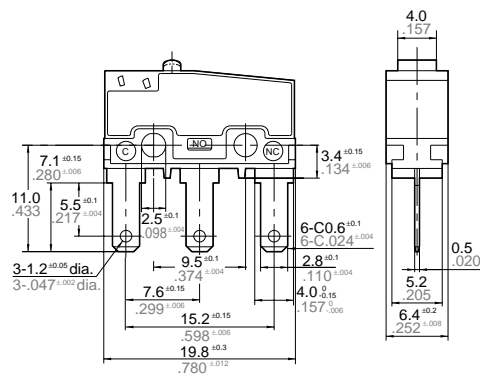
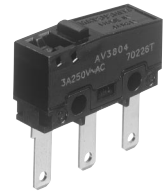

Dimensions other than drawn above is same as self-standing PC board terminal.

2.FS-T switches (Cross-line terminal type)

2-(1) PC board terminal Pin plunger

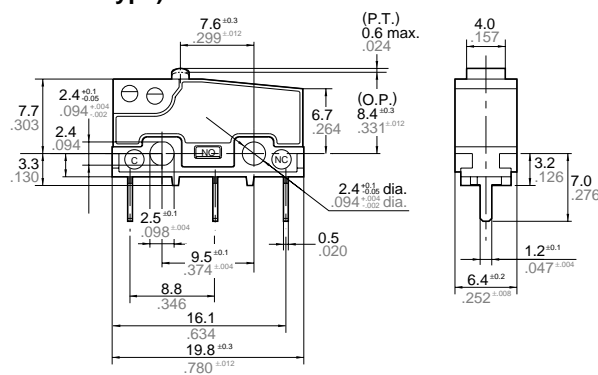

PC board pattern

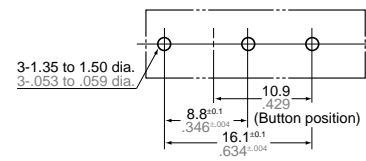

Pretravel, Max. mm inch	0.6 .024	
Movement differential, Max. mm inch	0.1 .004	
Overtravel, Min. mm inch	0.4 .016	
Operating position	Distance from mounting hole, mm inch	8.4 \pm 0.3 .331 \pm 0.12
	Distance from standoff, mm inch	11.7 \pm 0.4 .461 \pm 0.16

AV3,AVM3/AVT3,AVL3

mm inch General tolerance $\pm 0.25 \pm .010$

Short hinge lever

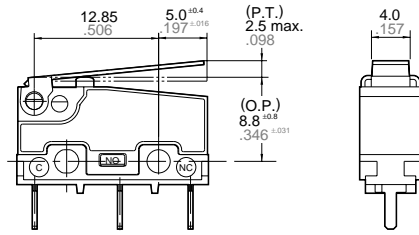

Pretravel, Max. mm inch	2.5 .098	
Movement differential, Max. mm inch	0.5 .020	
Overtravel, Min. mm inch	0.8 .031	
Operating position	Distance from mounting hole, mm inch	8.8±0.8 .346±.031
	Distance from standoff, mm inch	12.1±0.9 .476±.035

Hinge lever

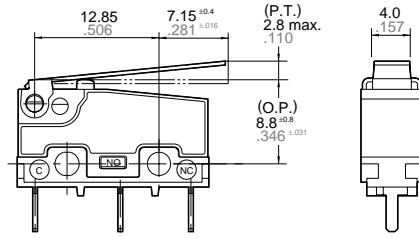

Pretravel, Max. mm inch	2.8 .110	
Movement differential, Max. mm inch	0.8 .031	
Overtravel, Min. mm inch	1.2 .047	
Operating position	Distance from mounting hole, mm inch	8.8±0.8 .346±.031
	Distance from standoff, mm inch	12.1±0.9 .476±.035

Long hinge lever

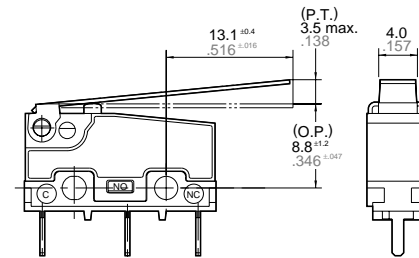
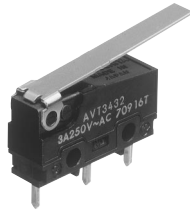

Pretravel, Max. mm inch	3.5 .138	
Movement differential, Max. mm inch	1.0 .039	
Overtravel, Min. mm inch	1.6 .063	
Operating position	Distance from mounting hole, mm inch	8.8±1.2 .346±.047
	Distance from standoff, mm inch	12.1±1.3 .476±.051

Simulated roller lever

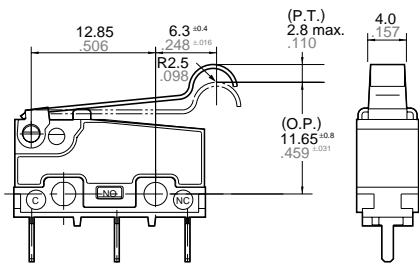

Pretravel, Max. mm inch	2.8 .110	
Movement differential, Max. mm inch	0.8 .031	
Overtravel, Min. mm inch	1.2 .047	
Operating position	Distance from mounting hole, mm inch	11.65±0.8 .459±.031
	Distance from standoff, mm inch	14.95±0.9 .589±.035

Roller lever

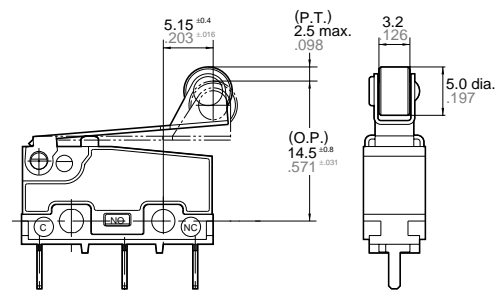

Pretravel, Max. mm inch	2.5 .098	
Movement differential, Max. mm inch	0.5 .020	
Overtravel, Min. mm inch	0.8 .031	
Operating position	Distance from mounting hole, mm inch	14.5±0.8 .571±.031
	Distance from standoff, mm inch	17.8±0.9 .701±.035

AV3,AVM3/AVT3,AVL3

2-(2) Self-standing solder terminal

mm inch General tolerance $\pm 0.25 \pm .010$

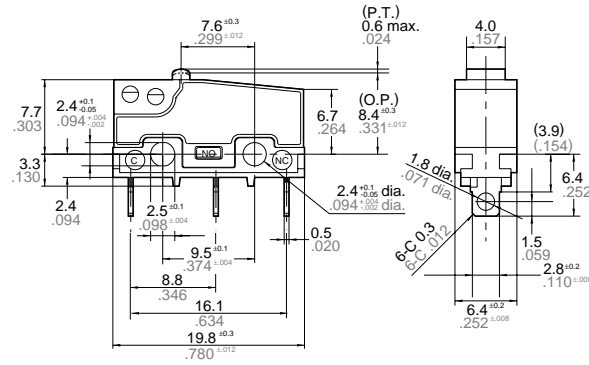

As for the dimensions of lever types, dimensions other than terminals are same as self-standing solder terminal.

2-(3) .110 Quick-connect terminal

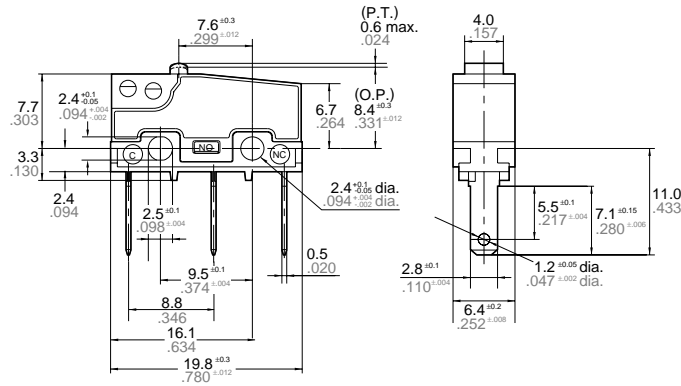

As for the dimensions of lever types, dimensions other than terminals are same as self-standing solder terminal.

AV3,AVM3/AVT3,AVL3

NOTES

1.Regarding fastening of switch body

In fastening the switch body, use flat filister head M2.3 screws, with tightening torque of not more than 3 kg-cm. To prevent loosening of the screws, it is recommended that spring washers be used with the screws and adhesive be applied to lock the screws.

After mounting the switch and making wiring connectors, the insulation distance between ground and each terminal should be confirmed as sufficient.

The positioning of the switch should be such that the pushbutton or actuator for the switch should not directly apply force to the operating section in the free condition. For a pushbutton, the force from the pushbutton should be applied in a perpendicular direction.

In setting the movement after operation, the over-travel should be set not less than 70% as a standard. Setting the movement at less than 70% of O.T. may cause troubles such as mis-contact and welding due to small contact force of the switch.

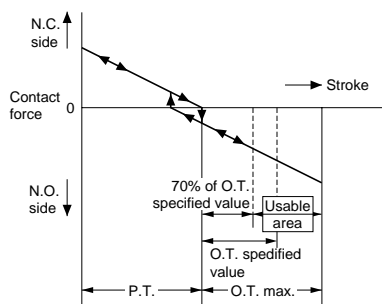

2.Soldering operation

For manual soldering: 60W soldering iron, soldering completed within 3 seconds; do not apply force to the terminals.

For automatic soldering tank: 250°C +482°F immersion, completed within 6 seconds, 350°C +662°F immersion, completed within 3 seconds.

Terminal portions must not be moved in min.1 minutes after soldering. Also no tensile strength of lead wires should be applied to terminals.

3.Regarding connector connections (.110 quick connect terminals)

For making connections, a dedicated receptacle for .110 quick connect terminals should be used, and the terminals should be inserted parallel to the receptacle. Consideration should be given to mounting so that no tensile load is applied to the lead wires.

4.In making the switch selection

Consideration should be given to provide for no interference up to +20% variation of the standard characteristics values.

5.Environment

Locations where corrosive gases having a bad influence on contacts are present, and locations where there is an excessive amount of siliceous or other abrasive dust should be avoided.

6.Cautions regarding use

This subminiatures switch has been designed as a dedicated switch for AC use, but it can be used for low capacity DC circuits.

Please select gold-clad contact types when loads are in the low-level area of 1mA up to 100mA and 5V up to 30V.

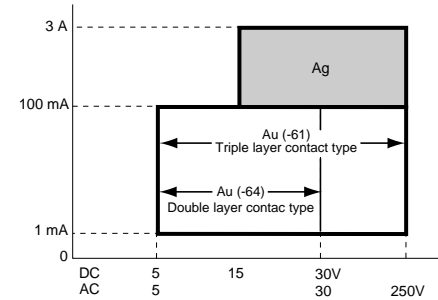

For switching of inductive loads (relays, solenoids, buzzers, etc.), in order to prevent damage to contacts due to the occurrence of arcing, an arc absorbing circuit should be applied.

7.Quality check under Actual Loading Condition

To assure reliability, check the switch under actual loading conditions. Avoid any situation that may adversely affect switching performance.

8.When using lever type switch, care should be taken not to apply undue force on the body from the opposite side or side ways to its operating direction.

AV3□□□G

NAIS	SUBMINIATURE SWITCHES (Contact gap: more than 1mm .039inch type)	FS (AV3□□□G) SWITCHES
-------------	--	---



FEATURES

- Conforming to IEC950
- Contact gap of greater than 1mm .039inch
- UL/CSA/VDE/SEMKO under application

TYPICAL APPLICATIONS

- Office equipment (printers, copiers)

ORDERING INFORMATION

Ex. AV 3 2 5 5 G

Type of switch	Version	Terminals	Actuators	Operating force by pin plunger, max.	Contact gap
FS switch	3: Standard	2: Self-standing solder terminal without guard 4: Self-standing PC terminal 8: .110 Quick-connect terminal	0: Pin plunger 1: Short hinge lever 2: Hinge lever 3: Long hinge lever 4: Simulated roller lever 5: Roller lever	5: 1.47 N {150 gf}	G: More than 1 mm type

PRODUCT TYPES

Actuator	Operating force Max.	Solder terminal	PC board terminal	.110 Quick- connect terminal
		Without guard		
Pin plunger	1.47 N {150 gf}	AV3205G3	AV3405G3	AV3805G3
Short hinge lever	0.59 N {60 gf}	AV3215G3	AV3415G3	AV3815G3
Hinge lever	0.54 N {55 gf}	AV3225G3	AV3425G3	AV3825G3
Long hinge lever	0.44 N {45 gf}	AV3235G3	AV3435G3	AV3835G3
Simulated roller lever	0.54 N {55 gf}	AV3245G3	AV3445G3	AV3845G3
Roller lever	0.59 N {60 gf}	AV3255G3	AV3455G3	AV3855G3

Remark: Unless you request otherwise, the switch comes with a stamp indicating its conformance to standards.

SPECIFICATIONS

1. Contact rating

- Silver alloy contact type

Voltage	Resistive load (cos φ≒1)
30 V DC	3 A

AV3□□□G

2. Characteristics

Item	Characteristics	
Expected life	Mechanical (O.T.: Specified value)	Min. 5×10^5 (at 60cpm)
	Electrical (O.T. max.)	Min. 10^4 (at 20cpm)
Breakdown voltage	Between non-continuous terminals	1,000 Vrms for 1 min. (at 10mA)
	Between each terminal and other exposed metal parts	2,000 Vrms for 1 min. (at 10mA)
	Between each terminal and ground	2,000 Vrms for 1 min. (at 10mA)
Insulation resistance	Min. 100MΩ (at 500 V DC)	
Contact resistance (Initial)	Max. 50mΩ (by voltage drop 6 to 8 V DC 1A)	
Vibration resistance	10 to 55 Hz at single amplitude of 0.75 mm (Contact opening: Max. 1 msec.)	
Shock resistance	Pin plunger type	294m/s ² {30G} (Contact distance: Max. 1 msec.)
	Lever type	147m/s ² {15G} (Contact distance: Max. 1 msec.)
Allowable operation speed (No load)	0.1 to 1,000 mm/s	
Max. switching frequency (No load)	300 cpm.	
Ambient temperature	-25°C to +85°C -13°F to +185°F (Not freezing below 0°C 32°F)	
Ambient humidity	Max. 85% R.H.	

Remark: Test conditions are in accordance with JIS C 4505.

3. Operating characteristics

Actuator	Operating force, Max.	Release force, Min.	Pretravel, Max. mm inch	Movement differential, Max. mm inch	Overtravel, Min. mm inch	Operating position, mm inch
Pin plunger	1.47 N {150 gf}	0.064 N {6.5 gf}	0.7 .028	0.2 .008	0.3 .012	8.4±0.3 .331±.012
Short hinge lever	0.59 N {60 gf}	0.015 N {1.5 gf}	2.5 .098	0.8 .031	0.6 .024	8.8±0.8 .346±.031
Hinge lever	0.54 N {55 gf}	0.013 N {1.3 gf}	2.8 .110	1.0 .039	0.8 .031	8.8±0.8 .346±.031
Long hinge lever	0.44 N {45 gf}	0.0098 N {1.0 gf}	3.5 .138	1.2 .047	1.2 .047	8.8±1.2 .346±.047
Simulated roller lever	0.54 N {55 gf}	0.013 N {1.3 gf}	2.8 .110	1.0 .039	0.8 .031	11.65±0.8 .459±.031
Roller lever	0.59 N {60 gf}	0.015 N {1.5 gf}	2.5 .098	0.8 .031	0.6 .024	14.5±0.8 .571±.031

DIMENSIONS

The same size as the standard FS/FS-T switches.
Please refer to "FS/FS-T switches pages" or our web site.
URL: <http://www.mew.co.jp/e-acg/>