

QUICK START GUIDE FOR DEMONSTRATION CIRCUIT 799 SYNCHRONOUS BUCK-BOOST CONVERTER WITH AUTOMATIC BURST MODE

LTC3442EDE

DESCRIPTION

Demonstration Circuit 799 is a high efficiency synchronous Buck-Boost converter using the LTC3442. The input range is from 2.4V to 5.5V, making it ideal for single-cell Lithium-Ion or three-cell NiCd/NiMH battery applications. This converter provides up to 95% efficiency, much higher than traditional Buck-Boost converters. For 2.7V minimum input voltage, this converter can provide up to 1.2A load current.

The output voltage is set at 3.3V. A different output voltage in the range of 2.4V to 5.25V can be obtained by changing one of the feedback resistors. The switching frequency is set at 1MHz, which is a good trade-off between efficiency and size. Adjusting RT can program the frequency between 300kHz to 2MHz. In shutdown, the IC itself draws less than 1 μ A.

The LTC3442 has manual or programmable Automatic Burst Mode operation and programmable average input current limit.

When using long wire connections to the input source (such as wall adaptors), there can be input over voltage transients during initial plug-in. C2 is installed on DC799 to damp the possible voltage transients. C2 is not needed for any application when the input source is close to the regulator. Please refer to Application Note 88 for details.

Design files for this circuit board are available. Call the LTC factory.

LTC is a trademark of Linear Technology Corporation

Table 1. Performance Summary (T_A = 25°C unless otherwise noted)

PARAMETER	CONDITION	VALUE
Minimum Input Voltage	-40°C to 85°C	2.4V
Maximum Input Voltage	-40°C to 85°C	5.5V
Output Voltage V _{OUT}	V _{IN} = 2.5V to 5.5V, I _{OUT} = 0A to 1.1A	3.3V \pm 4%
Maximum Output Current	V _{IN} = 2.5V	1.1A
Maximum Output Current	V _{IN} = 2.7V	1.2A
Typical Output Ripple V _{OUT}	V _{IN} = 3.6V, I _{OUT} = 1.1A (20MHz BW)	45mV _{PP}
Typical Switching Frequency	RT=43.2K	1MHz
Efficiency (Fixed Frequency Mode)	V _{IN} = 4.2V, I _{OUT} = 0.2A	93% Typical
	V _{IN} = 4.2V, I _{OUT} = 1.0A	90% Typical
On/Off Control	Off (40°C to 85°C)	0.4V MAX
	On (-40°C to 85°C)	1.4V MIN

QUICK START PROCEDURE

Demonstration circuit 799 is easy to set up to evaluate the performance of the LTC3442. Refer to Figure 1

for proper measurement equipment setup and follow the procedure below:

QUICK START GUIDE FOR DEMONSTRATION CIRCUIT 799

SYNCHRONOUS BUCK-BOOST CONVERTER WITH AUTOMATIC BURST MODE

NOTE: When measuring the input or output voltage ripple, care must be taken to avoid a long ground lead on the oscilloscope probe. Measure the input or output voltage ripple by touching the probe tip directly across the V_{in} or V_{out} and GND terminals. See Figure 2 for proper scope probe technique.

1. Place jumpers in the following positions:

- JP1** RUN
- JP2** DISABLE
- JP3** AUTO ON

2. With power off, connect the input power supply to V_{in} and GND.

3. Turn on the power at the input.

NOTE: Make sure that the input voltage does not exceed 5.5V.

4. Check for the proper output voltage. $V_{out} = 3.17V$ to $3.43V$.

NOTE: If there is no output, temporarily disconnect the load to make sure that the load is not set too high.

5. Once the proper output voltage is established, adjust the load within the operating range and observe the output voltage regulation, ripple voltage, efficiency and other parameters.

GRAPHICS

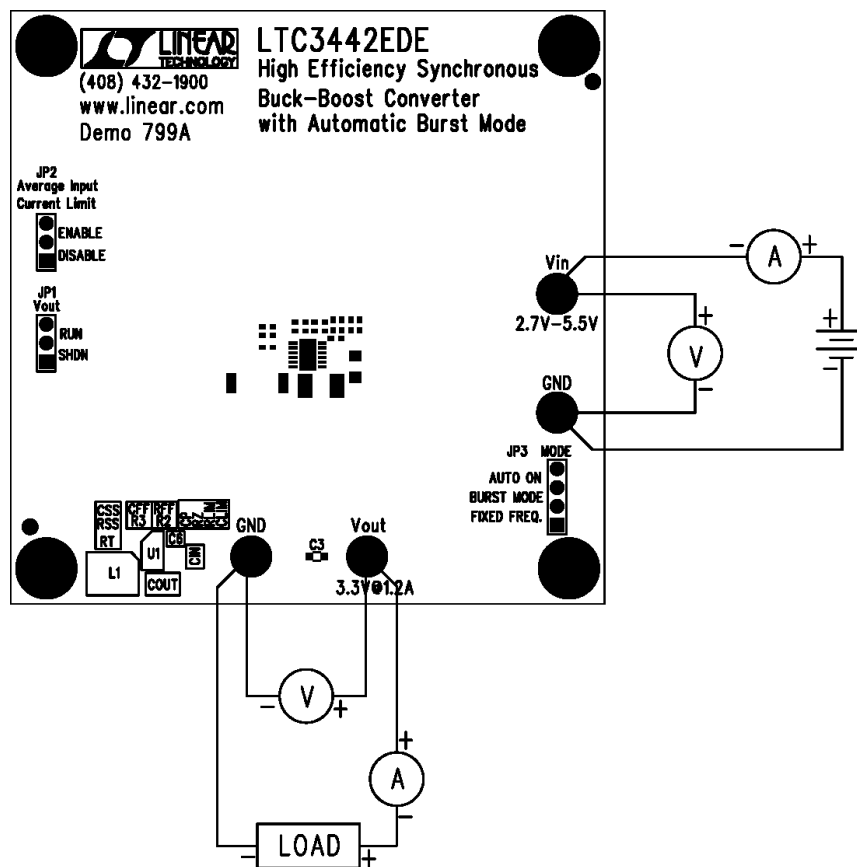

Figure 1. Proper Measurement Equipment Setup

QUICK START GUIDE FOR DEMONSTRATION CIRCUIT 799

SYNCHRONOUS BUCK-BOOST CONVERTER WITH AUTOMATIC BURST MODE

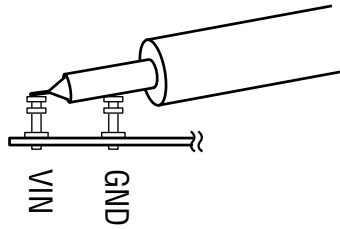

Figure 2. Measuring Input or Output Ripple

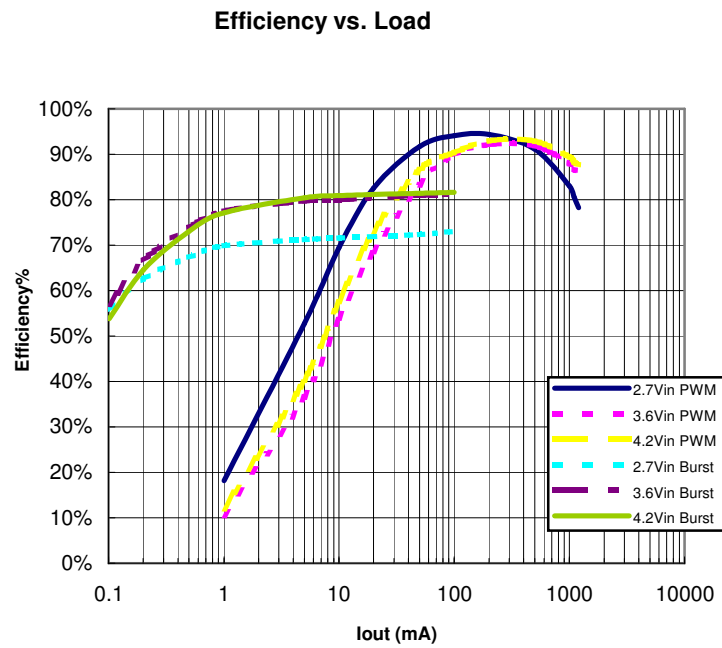

Figure 3. Efficiency of DC799

QUICK START GUIDE FOR DEMONSTRATION CIRCUIT 799

SYNCHRONOUS BUCK-BOOST CONVERTER WITH AUTOMATIC BURST MODE

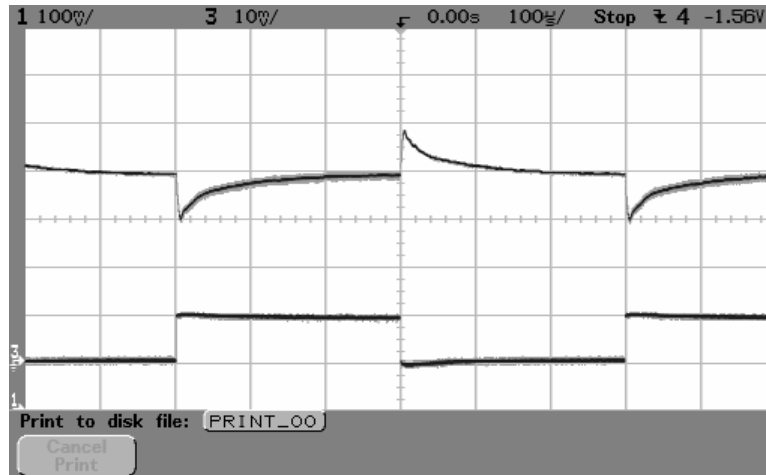
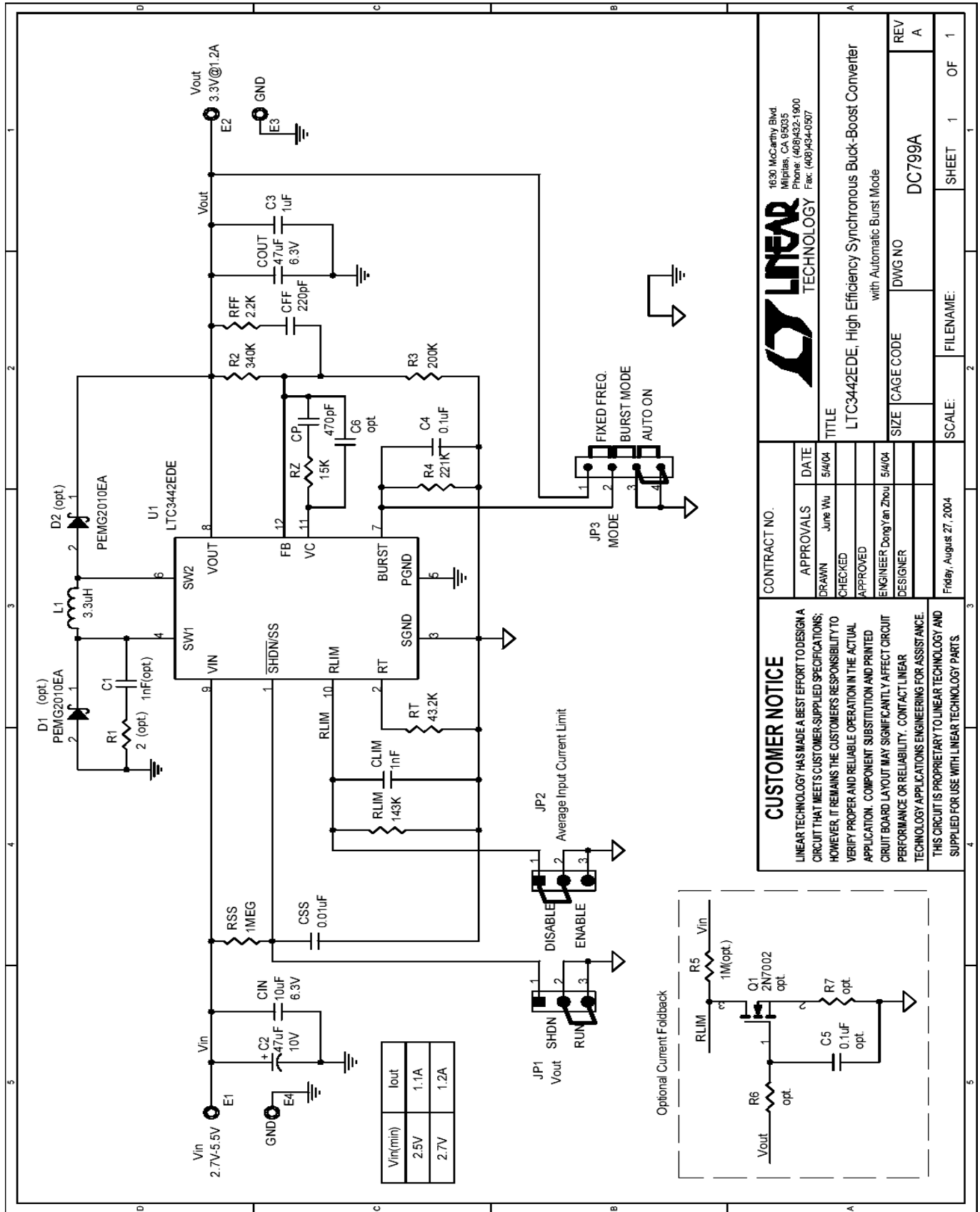

Figure 4. Load Transient Response ($V_{in}=3.6V$; top trace: V_{out} , 100mV/div; bottom trace: I_{out} load step: 200mA to 1.2A)

QUICK START GUIDE FOR DEMONSTRATION CIRCUIT 799

SYNCHRONOUS BUCK-BOOST CONVERTER WITH AUTOMATIC BURST MODE



CUSTOMER NOTICE

LINEAR TECHNOLOGY HAS MADE A BEST EFFORT TO DESIGN A CIRCUIT THAT MEETS CUSTOMER-SUPPLIED SPECIFICATIONS; HOWEVER, IT REMAINS THE CUSTOMER'S RESPONSIBILITY TO VERIFY PROPER AND RELIABLE OPERATION IN THE ACTUAL APPLICATION. COMPONENT SUBSTITUTION AND PRINTED CIRCUIT BOARD LAYOUT MAY SIGNIFICANTLY AFFECT CIRCUIT PERFORMANCE OR RELIABILITY. CONTACT LINEAR TECHNOLOGY APPLICATIONS ENGINEERING FOR ASSISTANCE.

THIS CIRCUIT IS PROPRIETARY TO LINEAR TECHNOLOGY AND SUPPLIED FOR USE WITH LINEAR TECHNOLOGY PARTS.

CONTRACT NO.

APPROVALS

DATE: 5/4/04

DESIGNED BY: Dong Yan Zhou

DESIGNER:

APPROVED:

CHECKED:

DRAWN: June Wu



1630 McCarthy Blvd
Milpitas, CA 95035
Phone: (408)432-1900
Fax: (408)434-0507

TITLE
LTC3442EDE, High Efficiency Synchronous Buck-Boost Converter with Automatic Burst Mode

SIZE CAGE CODE **DWG NO** DC799A **REV** A

SCALE: **FILENAME:** **SHEET** 1 OF 1

