

Features

- Carbon element
- Rotary switch option
- Wide assortment of resistance tapers
- RoHS compliant*



Model PDA17 is obsolete and not recommended for new designs. Model PDB18 is preferred.

PDA17 Series - 17 mm Rotary Potentiometer

Electrical Characteristics

Taper..... Linear, audio
 Standard Resistance Range 1 K ohms to 1 M ohms
 Standard Resistance Tolerance..... ±20 %
 Residual Resistance 1 % max.
 Switch Rating 1 A @ 12 VAC

Environmental Characteristics

Operating Temperature -10 °C to +50 °C
 Power Rating
 Linear 0.1 watt
 Audio 0.05 watt
 Maximum Operating Voltage
 Linear 200 V
 Audio 150 V
 Sliding Noise 47 mV max.

Mechanical Characteristics

Mechanical Angle 260 ° ±10 °
 Rotational Torque 50 to 350 g-cm
 Stop Strength 3 kg-cm min.
 Rotational Life 15,000 cycles
 Soldering Condition
 260 °C max. within 3 seconds
 Hardware One flat washer and mounting nut supplied per potentiometer with bushing
 Switch Torque..... 150 to 450 gf-cm
 Switch Action Angle 60 ° max.
 Contact Arrangement SPST

PDA17 Series Dimensions

K-Shaft (Metal 18-tooth Split Knurled Shaft)

L	15 (.591)	20 (.787)	25 (.984)	30 (1.181)
B	6 (.236)	9 (.354)	12 (.472)	12 (.472)

F-Shaft (Metal Flatted Type)

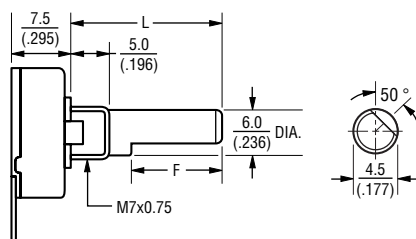

L	15 (.591)	20 (.787)	25 (.984)	30 (1.181)
F	7 (.276)	12 (.472)	12 (.472)	12 (.472)

Product Dimensions

PDA17-SS

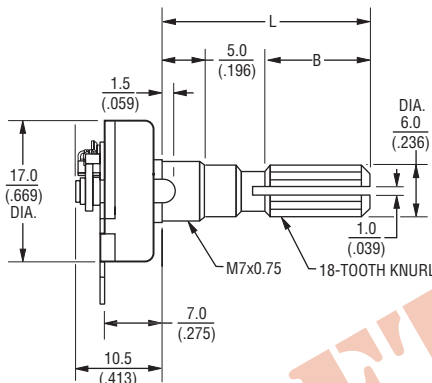

PDA17-SN

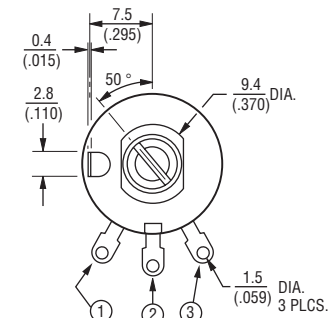
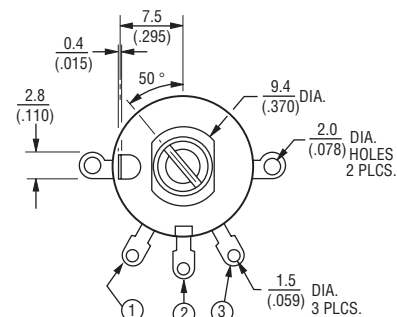
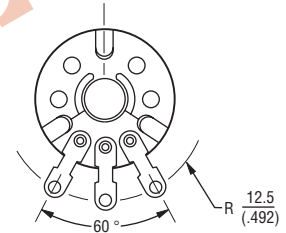
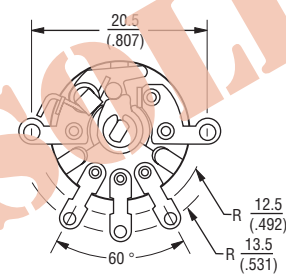
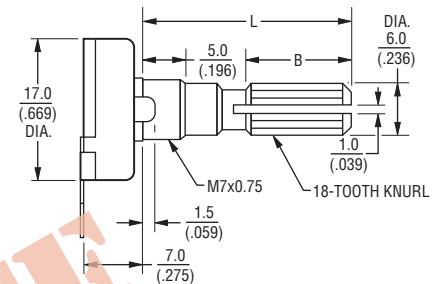

SHAFT SHOWN IN CCW POSITION

SHAFT SHOWN IN CCW POSITION

DIMENSIONS: MM (INCHES)

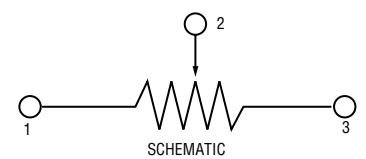

*RoHS Directive 2002/95/EC Jan 27, 2003 including Annex. Specifications are subject to change without notice. Customers should verify actual device performance in their specific applications.

Applications

- Audio/TV sets
- Car radio
- Portable electronics
- Appliances

PDA17 Series - 17 mm Rotary Potentiometer

BOURNS®

Product Dimensions

PDA17-AN

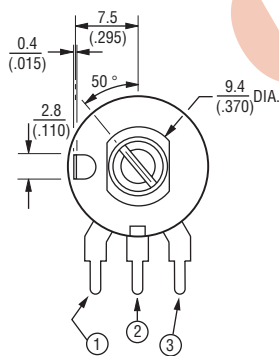
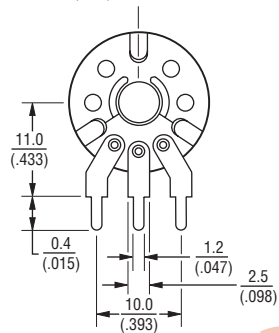
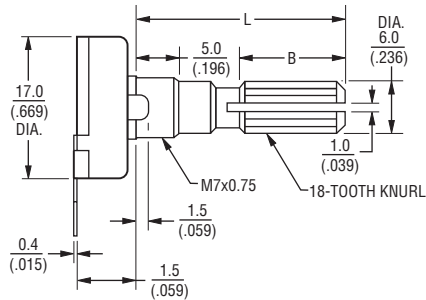

SHAFT SHOWN IN CCW POSITION

DIMENSIONS: $\frac{\text{MM}}{\text{(INCHES)}}$

PDA17-VN

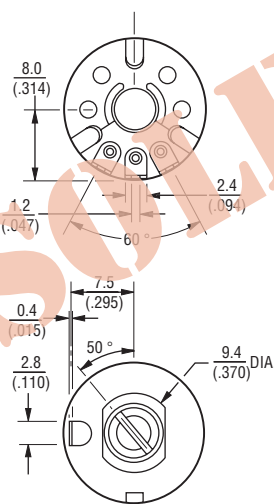
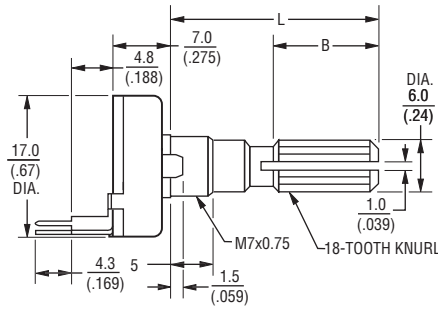

RECOMMENDED PCB LAYOUT

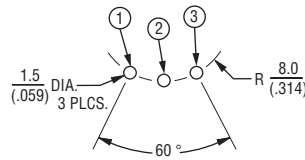

SHAFT SHOWN IN CCW POSITION

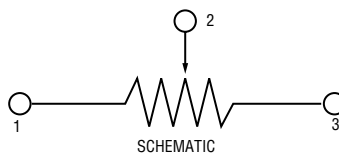

SCHEMATIC

PDA17-PS25

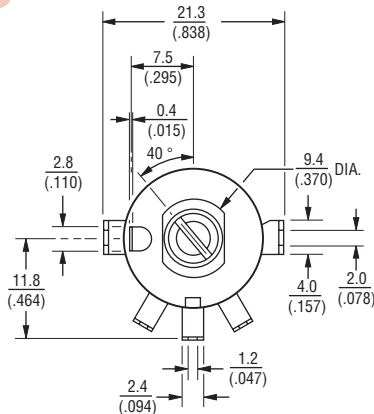
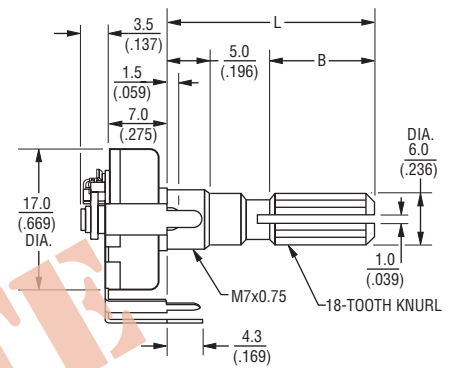

RECOMMENDED PCB LAYOUT

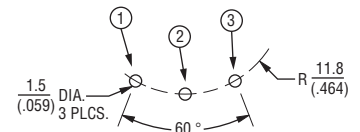
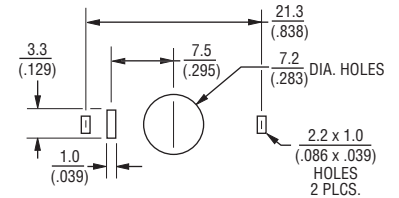

SHAFT SHOWN IN CCW POSITION

Specifications are subject to change without notice.
Customers should verify actual device performance in their specific applications.

PDA17 Series - 17 mm Rotary Potentiometer

BOURNS®

Product Dimensions

PDA17-PN25

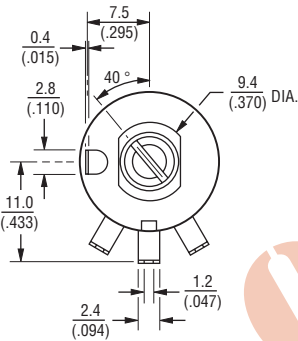
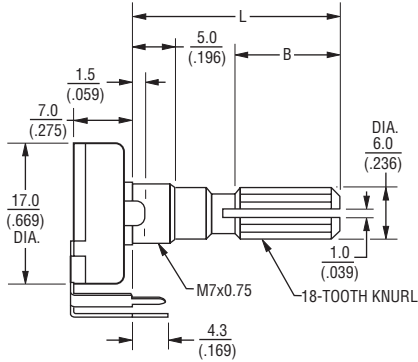

RECOMMENDED PCB LAYOUT

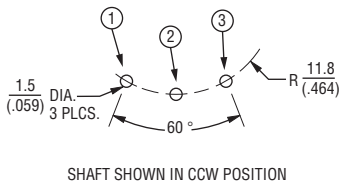
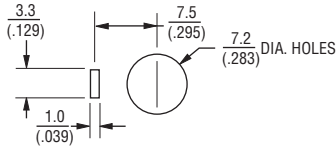

SHAFT SHOWN IN CCW POSITION

PDA17-VS25

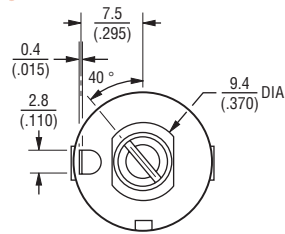
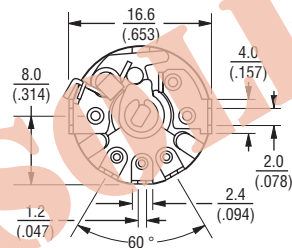
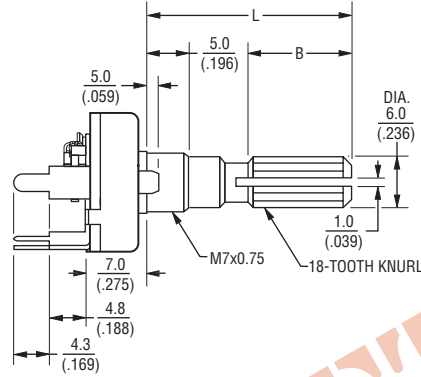

RECOMMENDED PCB LAYOUT

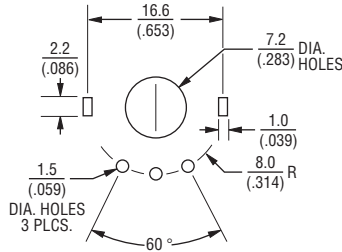

SHAFT SHOWN IN CCW POSITION

DIMENSIONS: $\frac{\text{MM}}{\text{(INCHES)}}$

How To Order

PDA17 - V N 20 - 102 A K

- Model
- Terminal Configuration
- S = Solder Lugs
 - A = PC Pins vertical/Down Facing
 - V = PC Pins horizontal/Rear Facing
 - P = PC Pins Front Facing
- Switch Option
- S = Rotary Switch
 - N = No Switch
- Standard Shaft Length
- 15 = 15 mm
 - 20 = 20 mm
 - 25 = 25 mm
 - 30 = 30 mm
- Resistance Code (See Table)
- Resistance Taper
- A = Audio Taper
 - B = Linear Taper
- Shaft Style
- K = Metal Knurled Shaft (18 Tooth Knurl)
 - F = Metal Flatted Shaft
- Other configurations or styles available.

Standard Resistance Table

Resistance (Ohms)	Resistance Code
1,000	102
2,000	202
5,000	502
10,000	103
20,000	203
50,000	503
100,000	104
200,000	204
500,000	504
1,000,000	105

Derating Curve

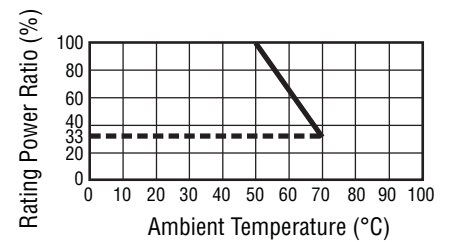

REV. 10/11

Specifications are subject to change without notice. Customers should verify actual device performance in their specific applications.