

DESCRIPTION

Demonstration circuit DC834 is a high voltage micro-power voltage regulator using the LT3014 low dropout linear regulator, which comes in a tiny SOT-23 package. The DC834 has an input voltage range from 3V to 80V, and an output voltage range between 1.22V and 60V. The DC834 is capable of delivering 20mA max. The DC supply current is typically only 6 μ A in operation, and

less than 1 μ A in shutdown. The DC834 is assembled with ceramic capacitors, to demonstrate the LT3014 maintaining stability with ceramic output capacitors. Due to its high input voltage range, the DC834 voltage regulator is ideally suited for automotive and industrial applications. **Gerber files for this circuit are available. Call the LTC Factory.**

QUICK START PROCEDURE

The DC834 is easy to set up to evaluate the performance of the LT3014. For proper measurement equipment configuration, set up the circuit according to the diagram in **Figure 1**.

Please follow the procedure outlined below for proper operation.

1. Before proceeding to test, insert a shunt into the OFF position of jumper JP4, and insert a shunt into jumper JP1, the 3.3V option.
2. Apply 5V across V_{in} and Gnd. Insert the jumper JP4 shunt into the ON position. Draw 1mA of load current. Measure V_{out} ; it should be 3.3V \pm 5% (3.135V to 3.465V).
3. Vary the input voltage from 5V to 80V and the load current from no load to 20 mA. V_{out} should measure 3.3V \pm 10% (2.97V to 3.63V).
4. Insert the jumper JP4 shunt into the OFF position and move the shunt in jumper JP1 into jumper JP2, the 5V output voltage option, and repeat the test. Re-insert jumper JP4 into the ON position. Just as in the 3.3 V_{out} test, the 5V output voltage should read $V_{out} \pm$ 5% tolerance under static line and load conditions, and \pm 10% tolerance under dynamic line and load conditions.
5. When finished evaluating, insert jumper JP4 shunt into the OFF position.

Warning - if long leads are used to power the demo circuit, the input voltage at the part could “ring”. This ringing could affect the operation of the circuit or even exceed the maximum voltage rating of the IC. To eliminate this, insert a small aluminum electrolytic capacitor (for instance, a Sanyo cap., part # 100CV10BS) on the pads between the input power and return terminals on the bottom of the demo board. The (greater) ESR of the aluminum electrolytic capacitor will dampen the (possible) ringing voltage due to the use of long input leads. On a normal, typical PCB, with short traces, the capacitor is not needed.

QUICK START GUIDE FOR DEMONSTRATION CIRCUIT 834

HIGH VOLTAGE LDO LINEAR REGULATOR

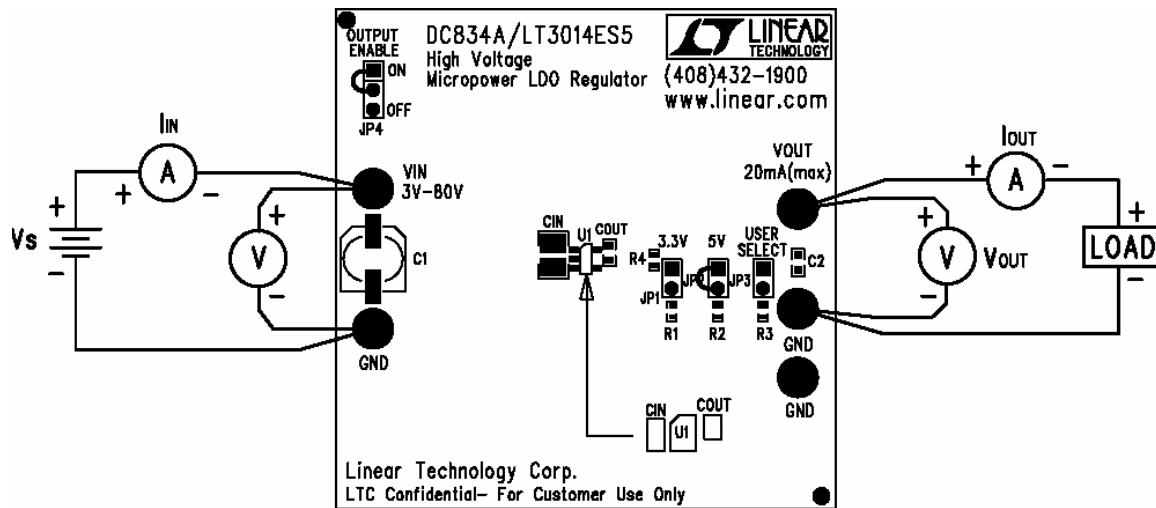

Figure1. Proper Measurement Equipment Setup

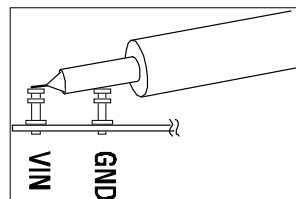

Figure 2. Measuring Input or Output Voltage Ripple

QUICK START GUIDE FOR DEMONSTRATION CIRCUIT 834

HIGH VOLTAGE LDO LINEAR REGULATOR

