

DC378 INTRODUCTION

Description

Demonstration circuit DC378 is a synchronous step-down buck regulator using the LTC[®]1778 No R_{SENSE}[™] switching regulator controller. The controller uses a valley current control architecture to deliver very low duty cycles without requiring a sense resistor. It provides high efficiency operation at light loads by means of discontinuous mode operation. Noise and RF interference are reduced by a forced continuous control pin. With a wide operating range of $V_{IN} = 4V$ to $36V$ and duty cycles of 2% to 90% at 200kHz, the LTC1778 is ideal for the applications such as notebook and palmtop computers, PDAs, battery chargers and distributed power systems.

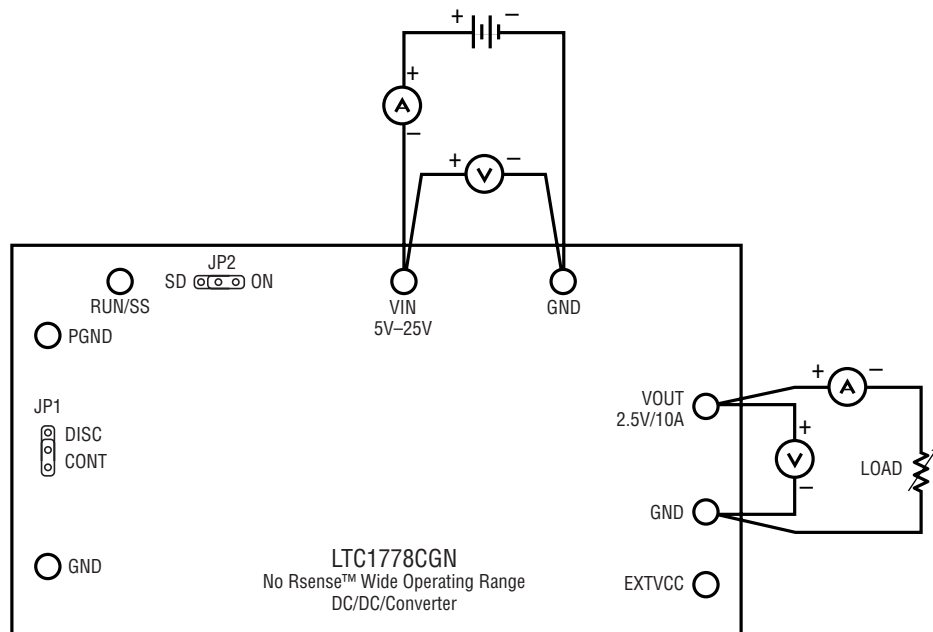

Figure 1. DC378A Test and Measurement Setup

Quick Start Guide

This demonstration board is easily set up to evaluate the performance of the LTC1778. Please consult Figure 1 and follow the procedure outlined below for proper operation.

1. Connect input power to the V_{IN} and GND terminals. Input voltage is limited to between 5V to 28V.

2. Connect the load between the V_{OUT} and GND terminals.
3. Set the FCB Jumper JP1 to the lower position (CONT) to force continuous synchronous operation at low loads, or to the upper position (DISC) to enable discontinuous mode operation at low loads.
4. To shut down the circuit, connect the RUN/SS pin to ground by setting jumper JP2 to the SD position. Set JP2 to the ON position to enable normal operation.
5. When measuring input or output ripple, see Figure 2 for proper scope probe technique.

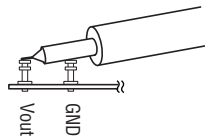
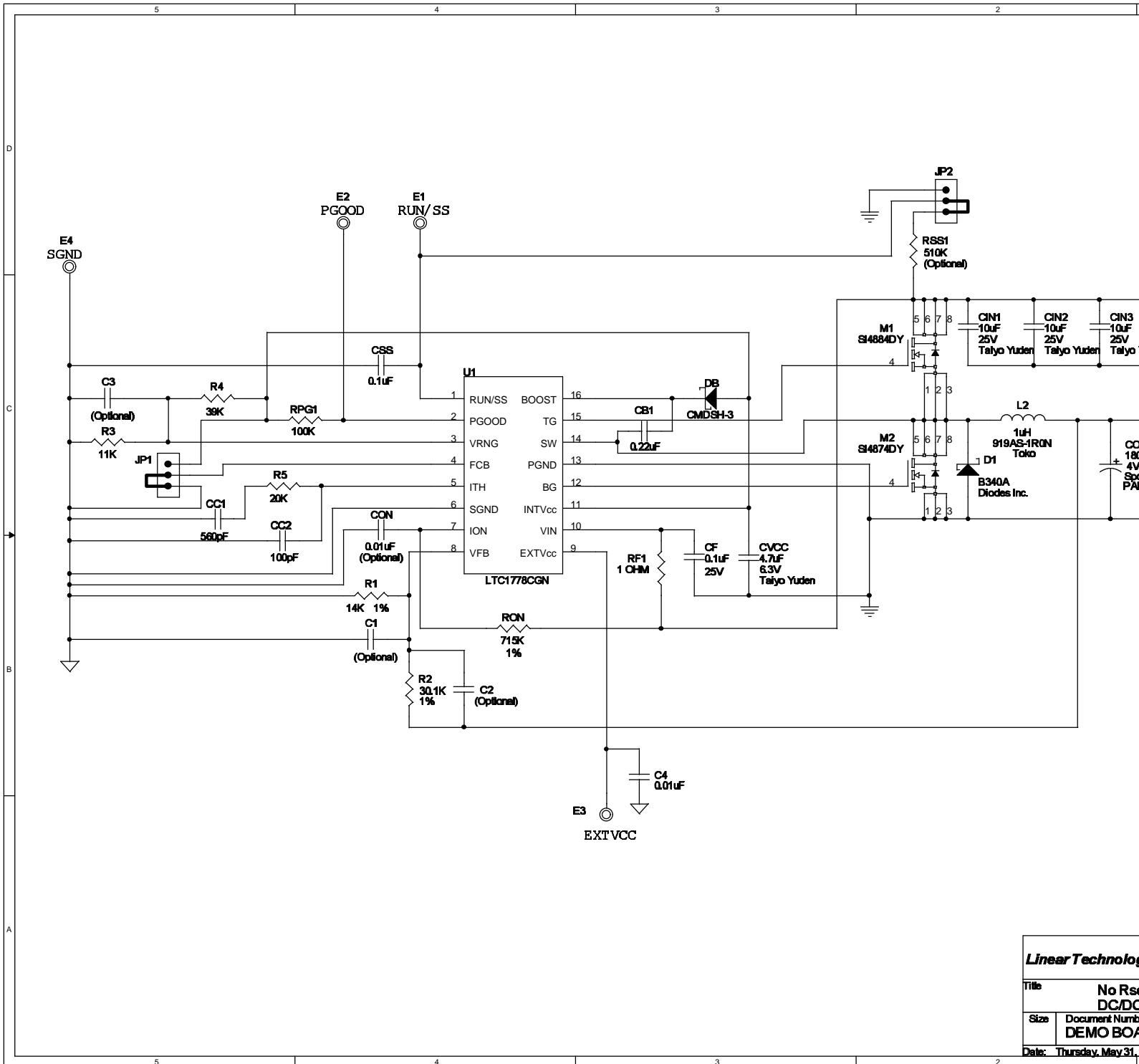

Figure 2. Scope Probe Placement for Measuring Output Ripple



Linear Technology	
Title	No Resistor DC/DC
Size	Document Number DEMO BOARD
Date:	Thursday, May 31, 2006

Item	Qty	Reference	Part Description	Manufacture / Part #
1	1	CB1	Capacitor, X7R 0.22uF 16V 10%	AVX 0805YC224KAT1A
2	1	CC1	Capacitor, X7R 560pF 25V 10%	AVX 06033C561MAT2A
3	1	CC2	Capacitor, NPO 100pF 50V 10%	AVX 06035A101KAT1A
4	1	CF	Capacitor, Y5V 0.1uF 25V 80%	AVX 06033G104ZAT2T
5	3	CIN1,CIN2,CIN3	Capacitor, X5R 10uF 25V 20%	Taiyo Yuden TMK432BJ106MM
6	0	CON (Optional)	Capacitor, X7R 0.01uF 25V 10%	AVX 06033C103KAT2A
7	2	COU1,COU2	Capacitor, Spcl. Poly. 180uF 4V 20%	PANASONIC EEFUE0G181R
8	1	CSS	Capacitor, X7R 0.1uF 16V 10%	AVX 06033C104KAT1A
9	1	CVCC	Capacitor, X5R 4.7uF 6.3V 20%	Taiyo Yuden JMK212BJ475MD-T
10	0	C1,C2,C3 (Optional)	Capacitor, X7R TBD 50V 10%	AVX 06035C101KAT1A
11	1	C4	Capacitor, X7R 0.01uF 25V 10%	AVX 06033C103KAT2A
12	1	C5	Capacitor, X5R 22uF 6.3V 20%	Taiyo Yuden JMK325BJ226MM-T
13	1	C6	Capacitor, Alum 10uF 35V 10%	SANYO 35CV10gX
14	1	DB	Schottky Diode, Super-Mini	Central Semi. Corp CMDSH-3
15	1	D1	Schottky Rect., 40V/3Amp	B340A Diodes Inc.
16	8	E1-E8	Turret	Mill Max 2501-2
17	2	JP1,JP2	Headers, 3 Pins 2mm Ctrs.	CommConn Con Inc. 2802S-03G2
18	1	L2	Inductor, 1uH, D104C	Toko 919AS-1R0N
19	1	M1	Mosfet., N-Chan. Red. Qg	Siliconix Si4884DY
20	1	M2	Mosfet., N-Chan. Red. Qg	Siliconix Si4874DY
21	1	RF1	Resistor, Chip 1 OHM 0.06W 5%	AAC CR16-1R0JM
22	1	RON	Resistor, Chip 715K 0.06W 1%	AAC CR16-7153FM
23	1	RPG1	Resistor, Chip 100K 0.06W 5%	AAC CR16-104JM
24	1	RSS1	Resistor, Chip 510K 0.06W 5%	AAC CR16-514JM
25	1	R1	Resistor, Chip 14K 0.06W 1%	AAC CR16-1402FM
26	1	R2	Resistor, Chip 30.1K 0.06W 1%	AAC CR16-3012FM
27	1	R3	Resistor, Chip 11K 0.06W 5%	AAC CR16-113JM
28	1	R4	Resistor, Chip 39K 0.06W 5%	AAC CR16-393JM
29	1	R5	Resistor, Chip 20K 0.06W 5%	AAC CR16-203JM
30	1	U1	I.C., NO Rsense Stepdown Controller	Linear Technology Corp. LTC1778CGN
31	2	XJP2,XJP1	SHUNT, CCIJ2MM-138-G	COMM CON. CCIJ2MM-138-G
32	4		STAND-OFF, NYLON HEX #4-40 1/4"	MICRO PLASTICS 14HTSP101
33	4		SCREW, #4-40, 1/4"	ANY
34	1		PRINTED CIRCUIT BOARDS	DEMO BOARD DC378A
35	2		STENCIL	STENCIL DC378A
36	1		SOLDER FRAME	FRAME S/N# 10695