

DESCRIPTION

Demonstration Circuit 697 is a quad output power supply intended for use in large TFT-LCD panels. The circuit features the LT1943 high current quad-output switching regulator and generates a 3.3V logic supply along with the triple output supply required for the TFT-LCD panels. With an input voltage range of 4.5V to 8V, a step down regulator provides 3.3V V_{LOGIC} with up to 1.5A current; a high power boost converter, a lower power boost converter and an inverting converter provide three independent output voltages AV_{DD} , V_{ON} and V_{OFF} required by the LCD panels. An internal high side PNP provides delayed turn on of the V_{ON} signal.

All four switchers are synchronized to the internal 1.2MHz clock, allowing the use of low profile inductors and ceramic capacitors. They all have soft-start to limit inrush current.

Long wires run from input sources (such as wall adaptors) can cause large voltage spikes during initial plug-in. C17 is installed on DC697 to damp the possible voltage spikes. C17 is not required for applications where input source is close to the regulator. Please refer to Application Note 88 for details.

Design files for this circuit board are available. Call the LTC factory.

LT is a trademark of Linear Technology Corporation

Table 1. Performance Summary ($T_A = 25^\circ\text{C}$ unless otherwise noted)

PARAMETER	CONDITION	VALUE
Minimum Input Voltage	-40°C to 85°C	4.5V
Maximum Input Voltage	-40°C to 85°C	8V
Output Voltage V_{LOGIC}	$V_{\text{IN}} = 4.5\text{V to } 8\text{V}$, $I_{\text{OUT}} = 0\text{A to } 1.5\text{A}$	3.3V $\pm 3\%$
Maximum Output Current at V_{LOGIC}	$V_{\text{IN}} = 4.5\text{V to } 8\text{V}$	1.5A
Typical Output Ripple V_{LOGIC}	$V_{\text{IN}} = 5\text{V}$, load at $V_{\text{LOGIC}} = 1.5\text{A}$ (20MHz BW)	19mV _{P-P}
Typical Output Ripple AV_{DD}	$V_{\text{IN}} = 5\text{V}$, load at $AV_{\text{DD}} = 500\text{mA}$ (20MHz BW)	33mV _{P-P}
Typical Switching Frequency		1.2MHz
On/Off Control	Logic Low Voltage-Off, -40°C to 85°C	0.4V MAX
	Logic High Voltage-On	2.4V MIN

QUICK START PROCEDURE

Demonstration circuit 697 is easy to set up to evaluate the performance of the LT1943. Refer to Figure 1 for proper measurement equipment setup and follow the procedure below:

NOTE: When measuring the input or output voltage ripple, care must be taken to avoid a long ground lead on the oscilloscope probe. Measure the input or output voltage ripple by touching the probe tip directly across the input or one of the outputs and GND terminals.

See Figure 2 for proper scope probe technique.

1. With power off, connect the input power supply to V_{in} and GND.
2. Set the input between 4.5V to 8V. Turn on the power at the input.

QUICK START GUIDE FOR DEMONSTRATION CIRCUIT 697

HIGH CURRENT QUAD OUTPUT SWITCHING REGULATOR FOR 5V INPUT TFT-LCD PANELS

3. Check for the proper output voltages. If there is no output, temporarily disconnect the load to make sure that the load is not set too high.
4. Once the proper output voltages are established, adjust the loads within the operating range and observe the output voltage regulation, ripple voltage, efficiency and other parameters.

serve the output voltage regulation, ripple voltage, efficiency and other parameters.

NOTE: If more than 20mA is needed at V_{ON} , connect L3 to a higher input, such as AV_{DD} .

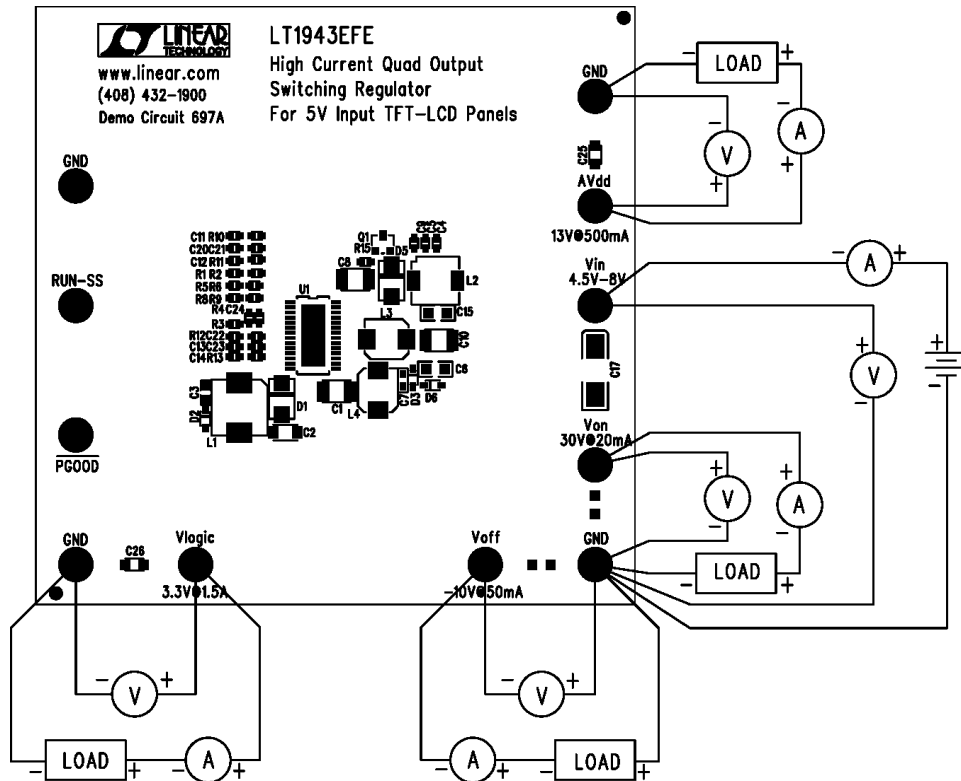

Figure 1. Proper Measurement Equipment Setup

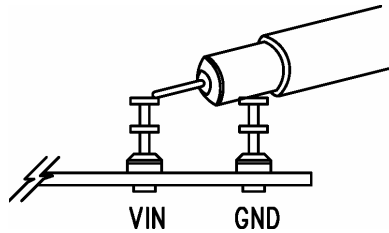
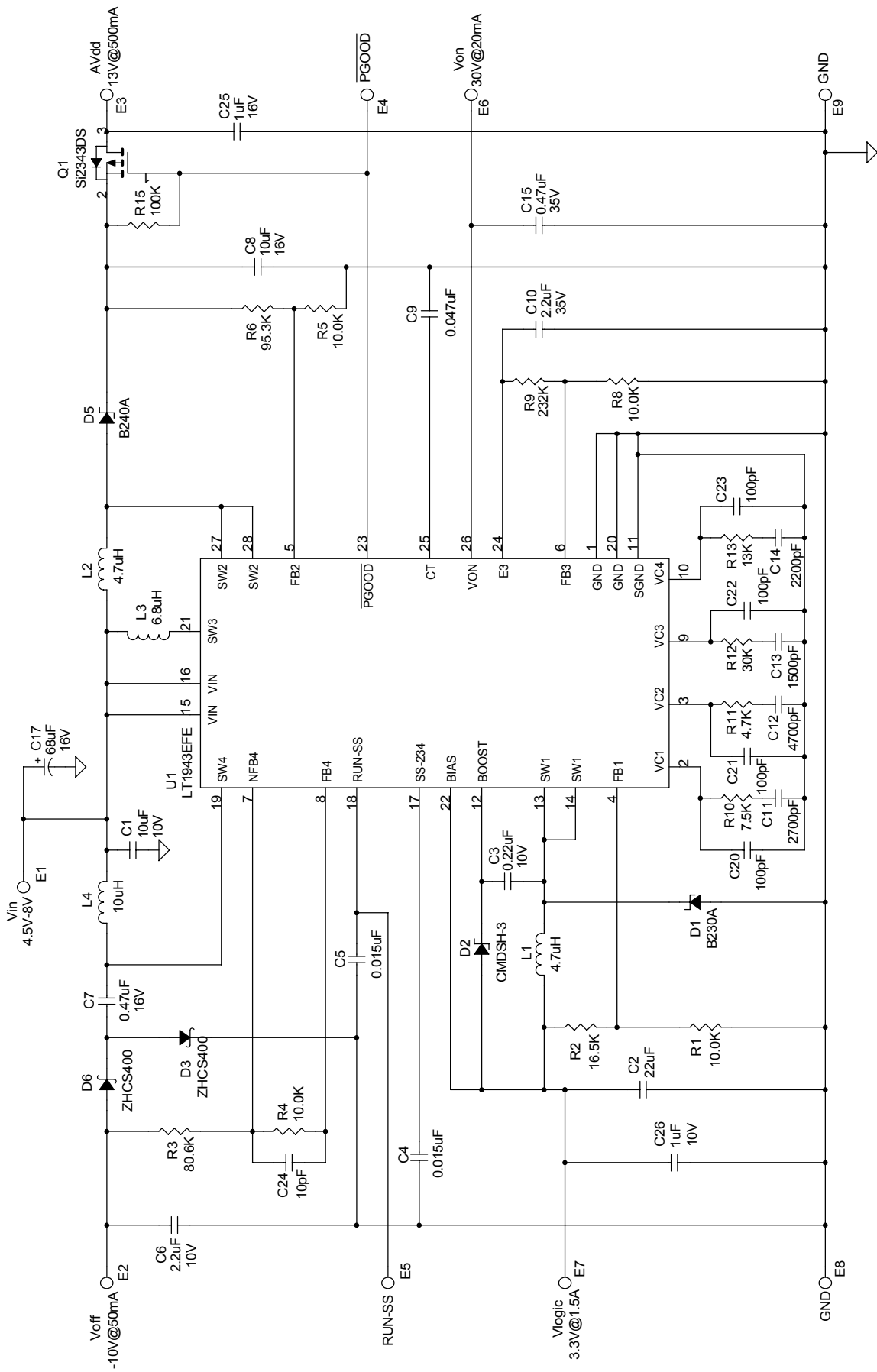

Figure 2. Measuring Input or Output Ripple



CUSTOMER NOTICE LINEAR TECHNOLOGY HAS MADE A BEST EFFORT TO DESIGN A CIRCUIT THAT MEETS CUSTOMER-SUPPLIED SPECIFICATIONS; HOWEVER, IT REMAINS THE CUSTOMER'S RESPONSIBILITY TO VERIFY PROPER AND RELIABLE OPERATION IN THE ACTUAL APPLICATION. COMPONENT SUBSTITUTION AND PRINTED CIRCUIT BOARD LAYOUT MAY SIGNIFICANTLY AFFECT CIRCUIT PERFORMANCE OR RELIABILITY. CONTACT LINEAR TECHNOLOGY APPLICATIONS ENGINEERING FOR ASSISTANCE. THIS CIRCUIT IS PROPRIETARY TO LINEAR TECHNOLOGY AND SUPPLIED FOR USE WITH LINEAR TECHNOLOGY PARTS.		CONTRACT NO. APPROVALS DRAWN: June Wu CHECKED: APPROVED: ENGINEER: Dongyan Zhou DESIGNER:	DATE 7/23/03
TITLE LT1943EFE, High Current Quad Output Switching Regulator For 5V Input TFT-LCD Panels			
SIZE	CAGE CODE	DWG NO	REV
		DC687A	A
SCALE:	FILENAME:	SHEET	OF
Tuesday, November 18, 2003		1	1

1630 McCarthy Blvd.
 Milpitas, CA 95035
 Phone: (415) 961-6000
 Fax: (415) 961-6507

LINEAR TECHNOLOGY

Item	Qty	Reference	Part Description	Manufacture / Part #
1	1	C1	CAP., X7R, 10uF, 10V, 20% 1210	Taiyo Yuden, LMK325BJ106MN
2	1	C8	CAP., X5R, 10uF, 16V, 20% 1210	Taiyo Yuden, EMK325BJ106MN
3	1	C2	CAP., X5R, 22uF, 6.3V, 20% 1206	Taiyo Yuden, JMK316BJ226ML
4	1	C3	CAP., X7R, 0.22uF, 10V, 20% 0603	AVX, 0603ZC224MAT2A
5	2	C5,C4	CAP., X7R, 0.015uF, 16V, 20% 0402	AVX, 0402YC153MAT2A
6	1	C6	CAP., X7R, 2.2uF, 10V, 10% 0805	MuRata, GRM21BR71A225KA01L
7	1	C7	CAP., X5R, 0.47uF, 16V, 20% 0603	AVX, 0603YD474MAT2A
8	1	C9	CAP., X5R, 0.047uF, 16V, 10% 0402	AVX, 0402YD473KAT2A
9	1	C10	CAP., X5R, 2.2uF, 35V, 20% 1210	Taiyo Yuden, GMK325BJ225MN
10	1	C11	CAP., X7R, 2700pF, 50V, 20%, 0402	AVX, 04025C272MAT2A
11	1	C14	CAP., X7R, 2200pF, 50V, 20% 0402	AVX, 04025C222MAT2A
12	1	C12	CAP., X7R, 4700pF, 50V, 20% 0402	AVX, 04025C472MAT2A
13	1	C13	CAP., X7R, 1500pF, 50V, 20% 0402	AVX, 04025C152MAT2A
14	1	C15	CAP., X5R, 0.47uF, 35V, 20% 0805	Taiyo Yuden, GMK212BJ474MG
15	1	C17	CAP., TANT, 68uF, 16V, 20% 6032	AVX, TAJC686M016R
16	4	C20-C23	CAP., X7R, 100pF, 50V, 20% 0402	AVX, 04025C101MAT2A
17	1	C24	CAP., NPO, 10pF, 50V, 10% 0402	AVX, 04025A100KAT2A
18	1	C25	CAP., X5R, 1.0uF 16V, 20% 0805	TAIYO YUDEN, EMK212BJ105MG
19	1	C26	CAP., X7R, 1.0uF 10V, 20% 0805	TAIYO YUDEN, LMK212BJ105MG
20	1	D1	Schottky Barrier REC., B230A SMA	Diodes Inc., B230A-13
21	1	D2	Schottky Diode, CMDSH-3 SOD-323	CENTRAL SEMI., CMDSH-3-LTC
22	2	D3,D6	Schottky Barries Dio., ZHCS400, SOD-323	ZETEX, ZHCS400TA
23	1	D5	Schottky Barrier REC., B240A SMA	Diodes Inc., B240A-13
24	1	Q1	P-Mosfet, Si2343DS, SOT-23	VISHAY, SI2343DS
25	11	E1-E11	TURRET,	MILL-MAX, 2501-2
26	1	L1	INDUCTOR, 4.7uH RLF7030	TDK, RLF7030T-4R7M3R4
27	1	L2	INDUCTOR, 4.7uH SLF6028	TDK, SLF6028T-4R7M1R6
28	1	L4	INDUCTOR, 10uH RLF5018	TDK, RLF5018T-100MR94
29	1	L3	INDUCTOR, 6.8uH RLF5018	TDK, RLF5018T-6R8M1R1
30	1	R10	RES., CHIP, 7.5K, 1/16W, 5% 0402	AAC, CR05-752JM
31	1	R11	RES., CHIP, 4.7K, 1/16W, 5% 0402	AAC, CR05-472JM
32	4	R1,R5,R8,R4	RES., CHIP, 10K, 1/16W, 1% 0402	AAC, CR05-1002FM
33	1	R12	RES., CHIP, 30K, 1/16W, 5% 0402	AAC, CR05-303JM
34	1	R13	RES., CHIP, 13K, 1/16W, 5% 0402	AAC, CR05-133JM

Item	Qty	Reference	Part Description	Manufacture / Part #
35	1	R2	RES., CHIP, 16.5K, 1/16W, 1% 0402	AAC, CR05-1652FM
36	1	R3	RES., CHIP, 80.6K, 1/16W, 1% 0402	AAC, CR05-8062FM
37	1	R6	RES., CHIP, 95.3K, 1/16W, 1% 0402	AAC, CR05-9532FM
38	1	R9	RES., CHIP, 232K, 1/16W, 1% 0402	AAC, CR05-2323FM
39	1	R15	RES., CHIP, 100K, 1/16W, 5% 0402	AAC, CR05-104JM
40	1	U1	I.C.LT1943EFE, TSSOP28FE	LINEAR., LT1943EFE
41	1		PRINTED CIRCUIT BOARD	FAB., DEMO CIRCUIT 697A
42	1		STENCIL	STENCIL 697A