

## DESCRIPTION

Demonstration circuit 870A-B is a high efficiency, high frequency buck converter, incorporating the LTC3410B monolithic synchronous regulator. The DC870 has an input voltage range of 2.25V to 5.5V, and is capable of delivering up to 300 mA of output current. It has an output voltage range from 0.8V to 5V, and an operating frequency range of 2.25 MHz (allowing the exclusive use of low profile surface mount components). In low load current operation, the LTC3410B operates in pulse-skip mode. The

DC870 is a very efficient circuit: up to 96%. These features, plus the LTC3410B coming in a tiny, low-profile 6-Pin SC70 package, make the DC870 demo board an ideal circuit for use in battery-powered, hand-held applications.

**Design files for this circuit board are available. Call the LTC factory.**

TM - Burst Mode is a trademark of Linear Technology Corporation

Table 1.

Performance Summary ( $T_A = 25^\circ\text{C}$ )

PARAMETER	CONDITION	VALUE
Minimum Input Voltage		2.25V
Maximum Input Voltage		5.5V
Output Voltage $V_{OUT}$	$V_{IN} = 2.25\text{V to } 5.5\text{V}, I_{OUT} = 0\text{A to } 0.3\text{A}$	$1.8\text{V} \pm 4\%$
Typical Output Ripple $V_{OUT}$	$V_{IN} = 5\text{V}, I_{OUT} = 0.3\text{A}$ (20 MHz BW)	20mVp-p
Output Regulation	Line	$\pm 1\%$
	Load	$\pm 1\%$
Nominal Switching Frequency		2.25 MHz

## QUICK START PROCEDURE

The DC870A-B is easy to set up to evaluate the performance of the LTC3410B. For proper measurement equipment configuration, set up the circuit according to the diagram in **Figure 1**. Before proceeding to test, insert jumper JP1 shunt into the off position, connecting the RUN pin to ground (GND), which shuts down the circuit.

**NOTE:** When measuring the input or output voltage ripple, care must be taken to avoid a long ground lead on the oscilloscope probe. Measure the input or out-

put voltage ripple by touching the probe tip directly across the  $V_{in}$  or  $V_{out}$  and GND terminals. See Figure 2 for proper scope probe technique.

1. Connect the input power supply and the load to the board. Do not hot-plug  $V_{in}$  or increase  $V_{in}$  over the rated maximum supply voltage of 5.5V, or the part may be damaged. Refer to figure 1 for the proper measurement equipment setup.

# QUICK START GUIDE FOR DEMONSTRATION CIRCUIT 870A-B

## HIGH EFFICIENCY MONOLITHIC SYNCHRONOUS BUCK REGULATOR

---

2. Apply 3.3V at  $V_{in}$ . Measure  $V_{out}$ ; it should read 0V. If desired, one can measure the shutdown supply current at this point. The supply current will be approximately 1  $\mu$ A in shutdown.
3. Turn on the circuit by inserting the shunt in jumper JP1 into the ON position. The output voltage should be regulating. Measure  $V_{out}$  - it should measure 1.8V +/- 2%.
4. Vary the input voltage from 2.25V to 5.5V and adjust the load current from 0 to 0.3A.  $V_{out}$  should read between 1.8V +/- 3%.
5. Measure the output ripple voltage at any output current level; it usually will measure less than 20 mVAC.
6. Observe the voltage waveform at the switch node (one pin of the inductor). Verify the switching frequency is between 1.8 MHz and 2.7 MHz ( $T = 0.56 \mu$ s and  $0.37 \mu$ s), and that the switch node waveform is rectangular in shape.

When finished, turn off the circuit by inserting the shunt in jumper JP1 into the OFF position.

# QUICK START GUIDE FOR DEMONSTRATION CIRCUIT 870A-B

## HIGH EFFICIENCY MONOLITHIC SYNCHRONOUS BUCK REGULATOR

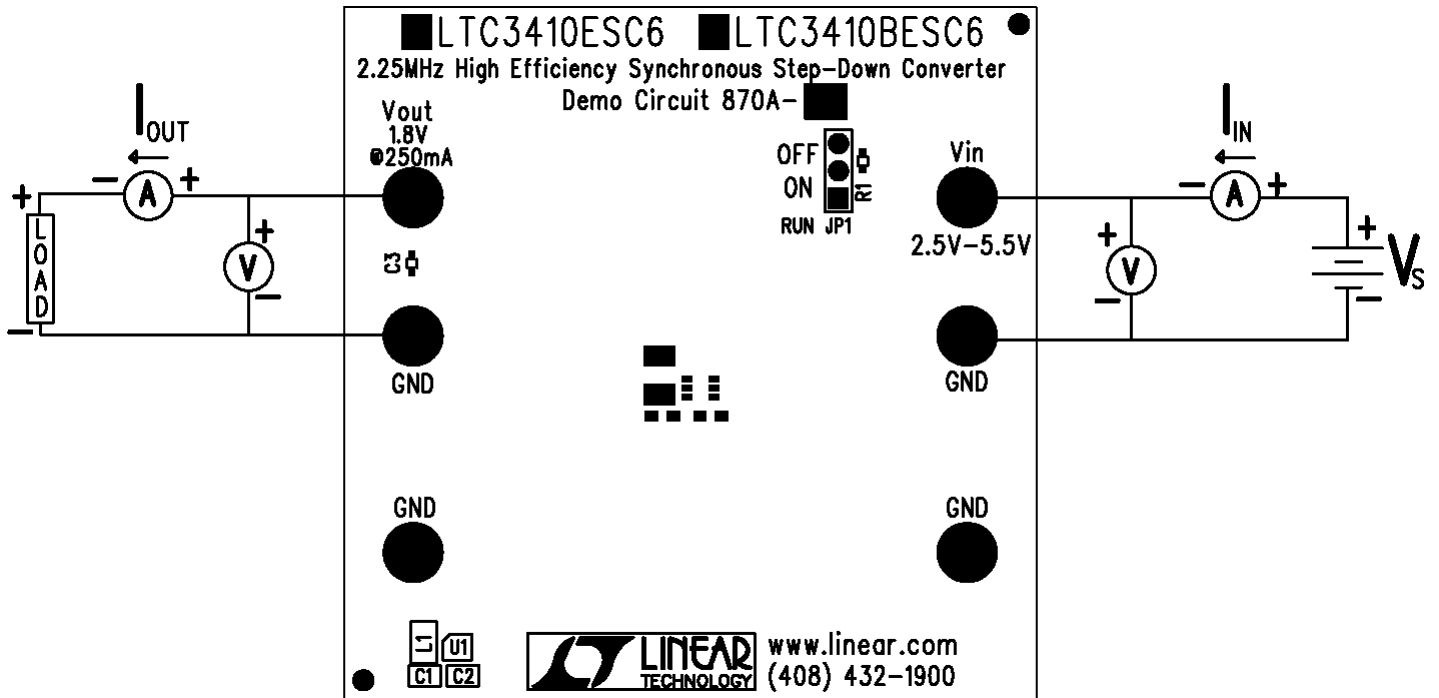

Figure 1. Proper Measurement Equipment Setup

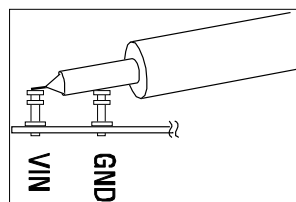
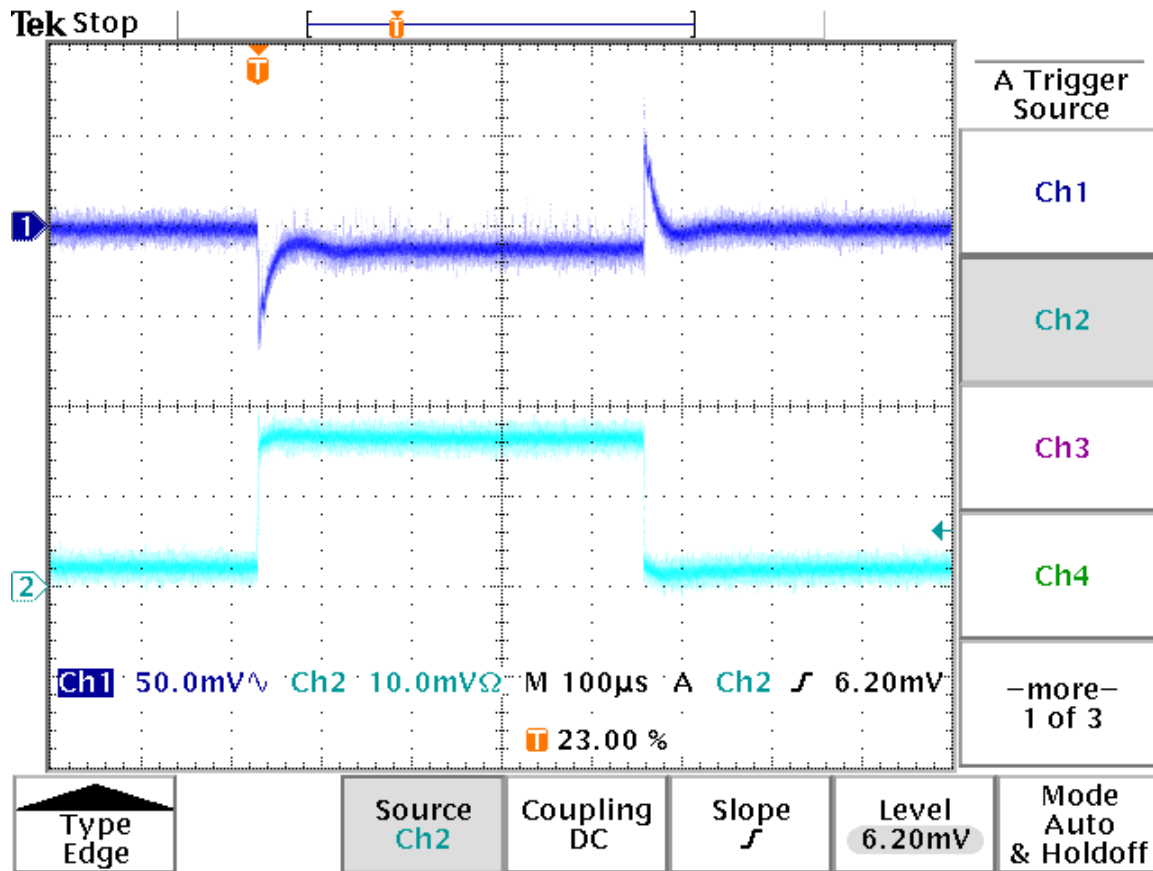

Figure 2. Measuring Input or Output Ripple

# QUICK START GUIDE FOR DEMONSTRATION CIRCUIT 870A-B

## HIGH EFFICIENCY MONOLITHIC SYNCHRONOUS BUCK REGULATOR



**Figure 3. Load Step Response**

$V_{in} = 3.3V$ ,  $V_{out} = 1.8V$ ,  $I_{out}$  Step = 0.2A

Trace 1: Output Voltage (50 mV/div AC)

Trace 2: Output Current (0.1A/div)

# QUICK START GUIDE FOR DEMONSTRATION CIRCUIT 870A-B

## HIGH EFFICIENCY MONOLITHIC SYNCHRONOUS BUCK REGULATOR

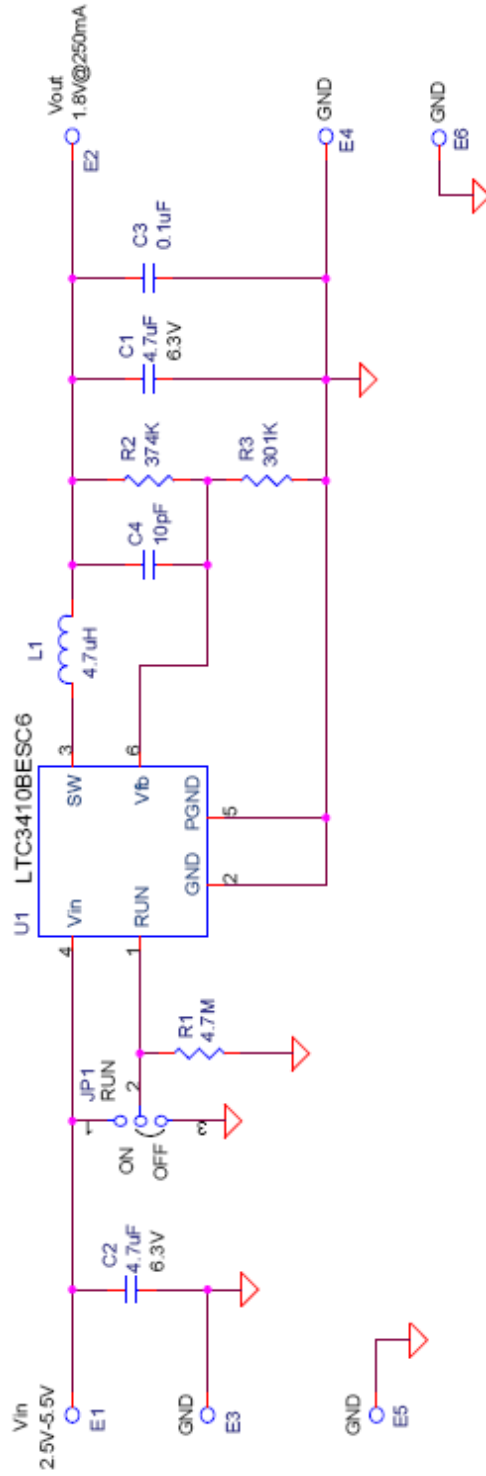

<b>CUSTOMER NOTICE</b>		<b>CONTRACT NO.</b>	
LINEAR TECHNOLOGY HAS MADE A BEST EFFORT TO DESIGN A CIRCUIT THAT MEETS CUSTOMER-SUPPLIED SPECIFICATIONS; HOWEVER, IT REMAINS THE CUSTOMER'S RESPONSIBILITY TO VERIFY PROPER AND RELIABLE OPERATION IN THE ACTUAL APPLICATION. COMPONENT SUBSTITUTION AND PRINTED CIRCUIT BOARD LAYOUT MAY SIGNIFICANTLY AFFECT CIRCUIT PERFORMANCE OR RELIABILITY. CONTACT LINEAR TECHNOLOGY APPLICATIONS ENGINEERING FOR ASSISTANCE.		1630 McCauley Blvd. Milpitas, CA 95035 Phone: (408)432-1900 Fax: (408)434-0507	
THIS CIRCUIT IS PROPRIETARY TO LINEAR TECHNOLOGY AND SUPPLIED FOR USE WITH LINEAR TECHNOLOGY PARTS.		<b>LINEAR TECHNOLOGY</b>	
		TITLE	
		LTC3410ESC6 2.25MHz High Efficiency Synchronous Step-Down Converter	
		SIZE	DWG NO
		CAGE CODE	DC870A-B
		SCALE	REV
		Wednesday, February 25, 2009	A
		FILENAME	SHEET 1 OF 1