

DESCRIPTION

Demonstration circuit 741 is an ultra-low dropout voltage supply using the LTC3025 linear regulator, which comes in a small 2mm x 2mm 6-Pin DFN package. The DC741 has an input voltage range from 0.9V to 5.5V, an output voltage range between 0.4V and 2.6V, and is capable of delivering 300 mA max of output current. The 0.4V reference of the LTC3025 allows the DC741 to supply power to very low voltage applications. DC741 is also an excellent choice for post regulation of step-down

switching regulators, creating a high efficiency low-noise supply. The DC741 comes assembled with small ceramic capacitors, showing the LTC3025 ability to maintain stability with ceramic output capacitors.

Gerber files for this circuit are available. Call the LTC Factory.

QUICK START PROCEDURE

DC741 is easy to set up to evaluate the performance of the LTC3025. For proper measurement equipment configuration, set up the circuit according to the diagram in Figure 1.

Please follow the procedure outlined below for proper operation.

1. Before proceeding to test, insert jumper JP5 into the OFF position, and insert a shunt into jumper JP2 for 1.2V output.
2. Apply 1.3V to V_{in} (100 mV above V_{out}), and 5V to V_{bias} .

Caution: The bias voltage must be 1.4V, or greater, above the output voltage, and it must be 2.5V, or greater, for the circuit to regulate.

Insert jumper JP5 into the ON position. Measure V_{out} ; it should be 1.2V \pm 2% (1.176V to 1.224V).

3. Vary the input voltage from 1.3V to 5.5V and the load current from no load to 300 mA. V_{out} should measure 1.2V \pm 2% (1.176V to 1.224V).

LTC is a trademark of Linear Technology Corporation.

4. Insert jumper JP5 into the OFF position and move the shunt from jumper JP2 into any of the remaining output voltage options: 0.8V, 1.5V, or 1.8V. Re-insert jumper JP5 into the ON position. Just as in the 1.2V $_{out}$ test, the output voltage should read $V_{out} \pm 2\%$ tolerance under static line and load conditions, and $\pm 2\%$ tolerance under dynamic line and load conditions.
5. When finished evaluating, insert jumper JP5 into the OFF position.

Note - If the power for the demo board is carried in long leads, the input voltage at the part could "ring", due to the inductance in the long leads. This ringing could affect the operation of the circuit or even exceed the maximum voltage rating of the IC. To eliminate the ringing, a small tantalum capacitor (for instance, an AVX part # TAJW106M025R) was inserted on the pads between the input power and return terminals on the bottom of the demo board. The (greater) ESR of the tantalum will dampen the (possible) ringing voltage due to the use of long input leads. On a normal, typical PCB, with short traces, the capacitor is not needed.

QUICK START GUIDE FOR DEMONSTRATION CIRCUIT 741

DUAL OUTPUT LOW NOISE LDO REGULATORS

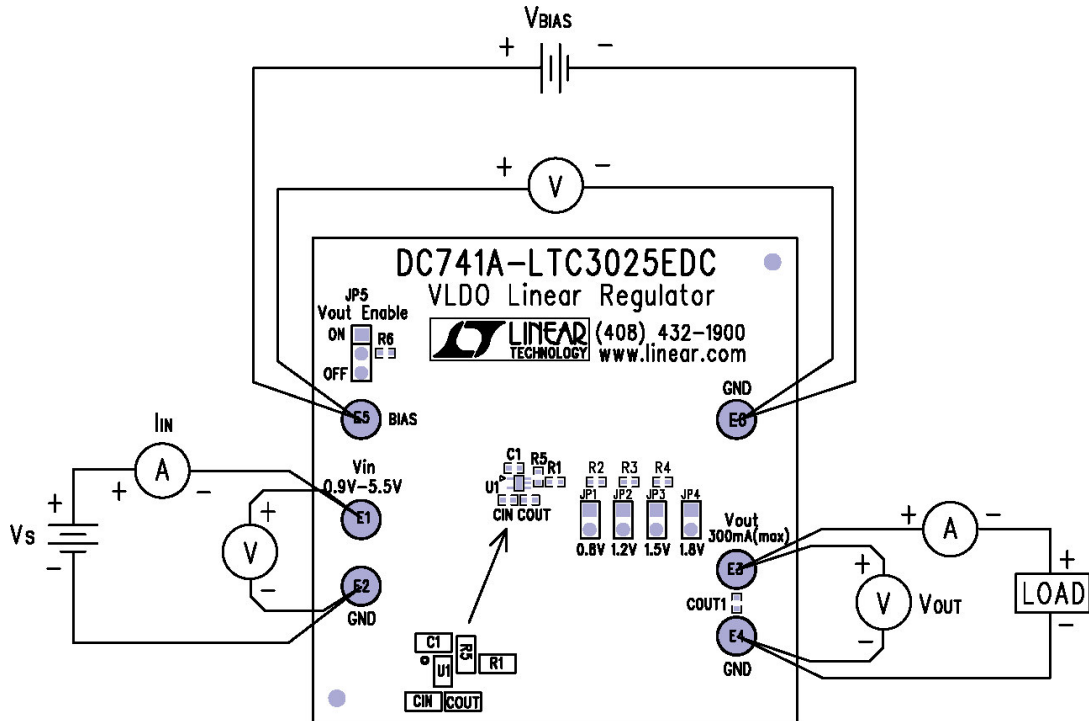

V_{BIAS} must exceed V_{out} by 1.4V or greater

Figure1. Proper Measurement Equipment Setup

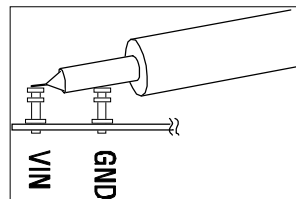
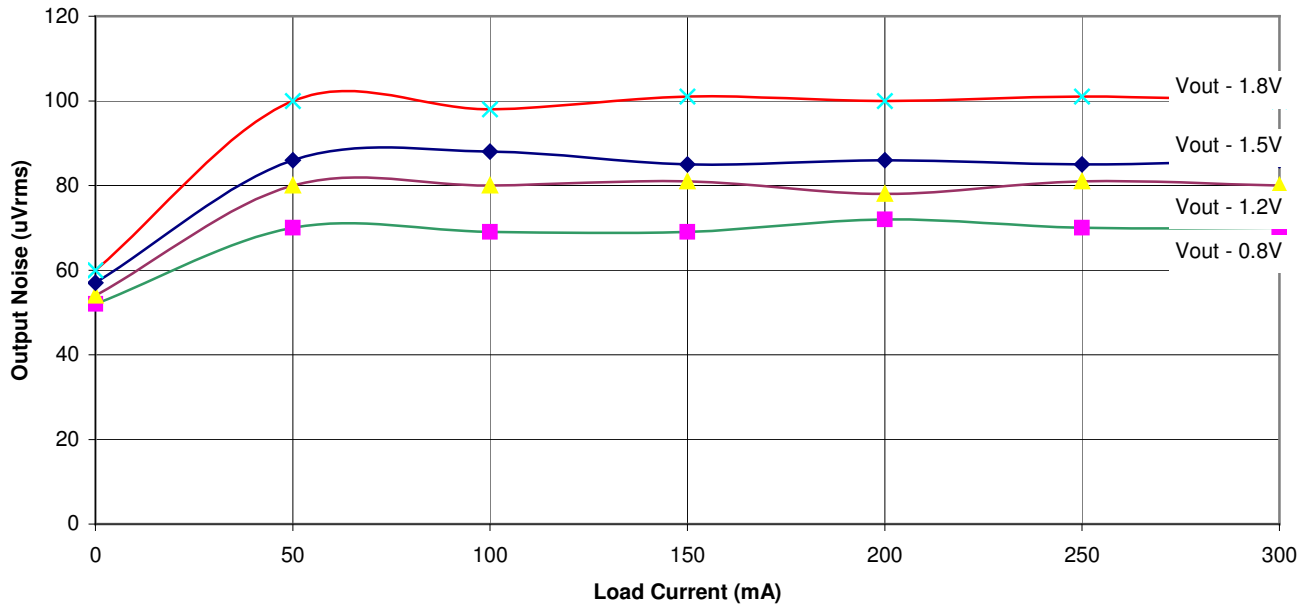

Figure 2. Measuring Input or Output Ripple

QUICK START GUIDE FOR DEMONSTRATION CIRCUIT 741

DUAL OUTPUT LOW NOISE LDO REGULATORS

RMS Output Noise vs. Load Current
(10 Hz to 100 kHz)



Output Noise Spectral Density

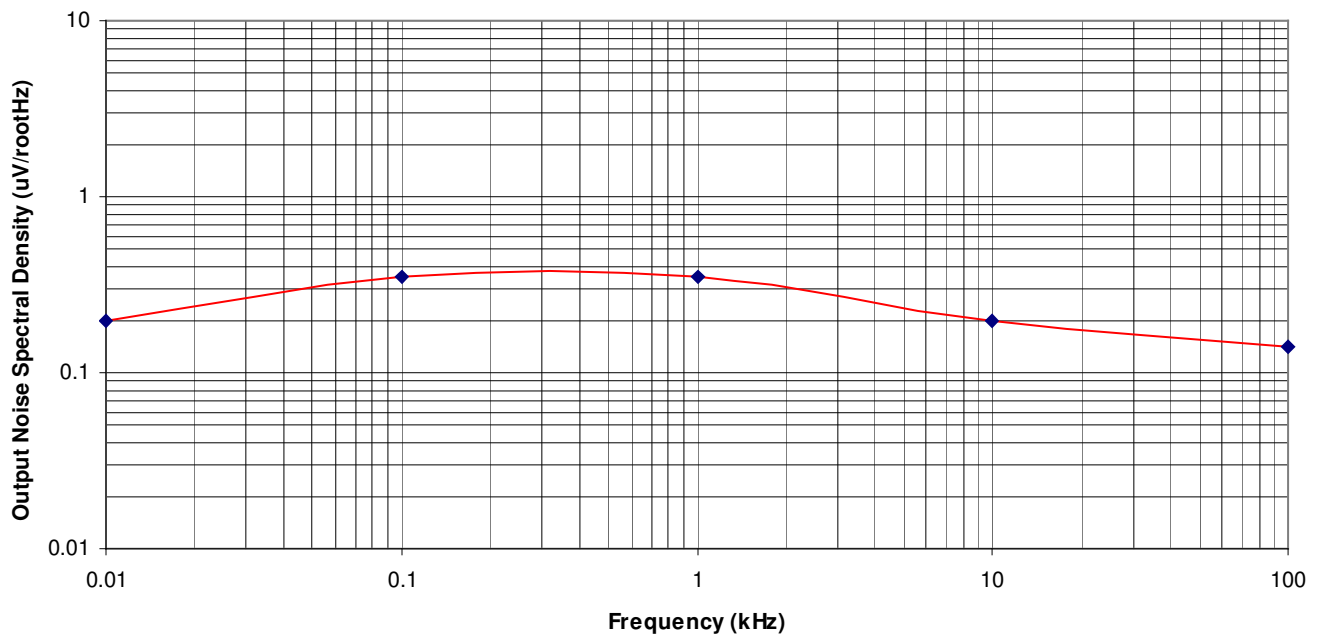

QUICK START GUIDE FOR DEMONSTRATION CIRCUIT 741

DUAL OUTPUT LOW NOISE LDO REGULATORS

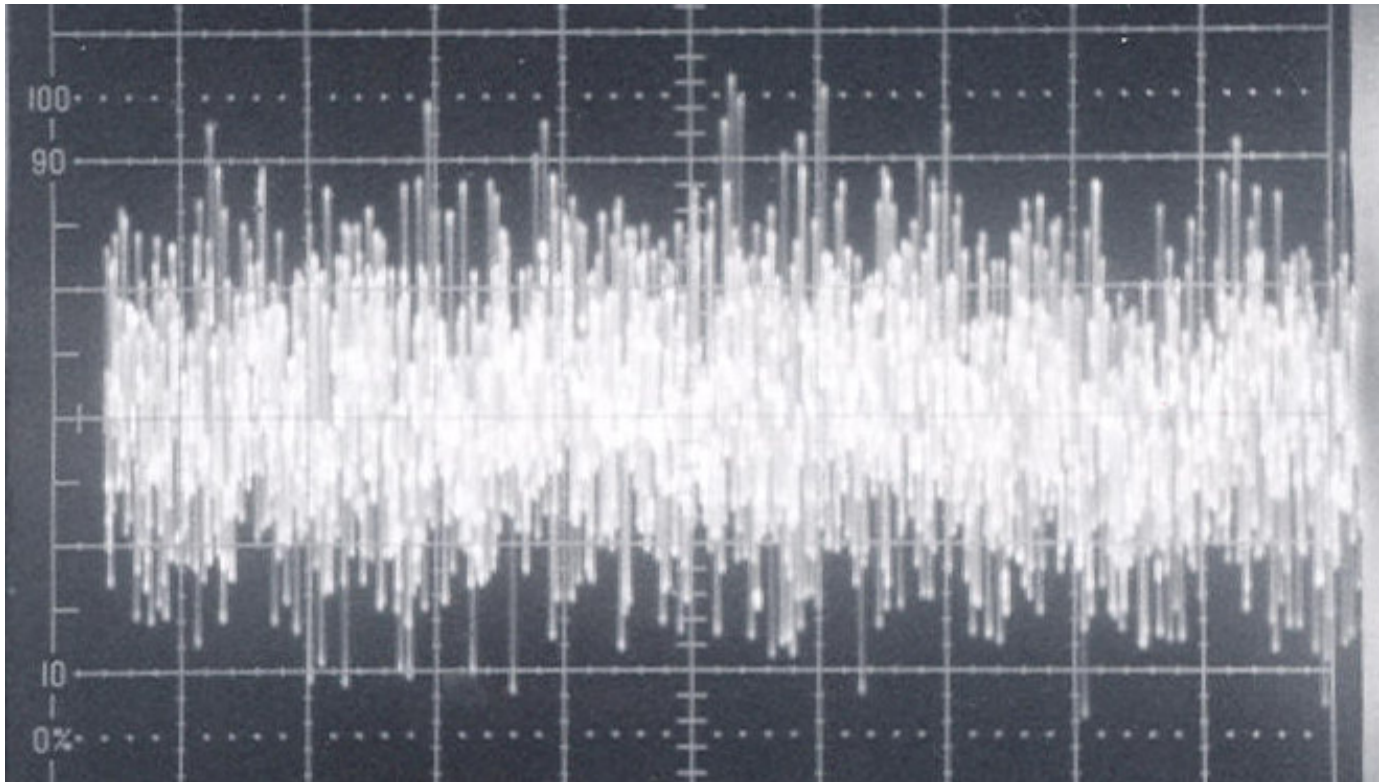

10 Hz to 100 kHz Output Noise (X-Axis Scale: 1ms/div; Y-Axis Scale: 100uV/div)

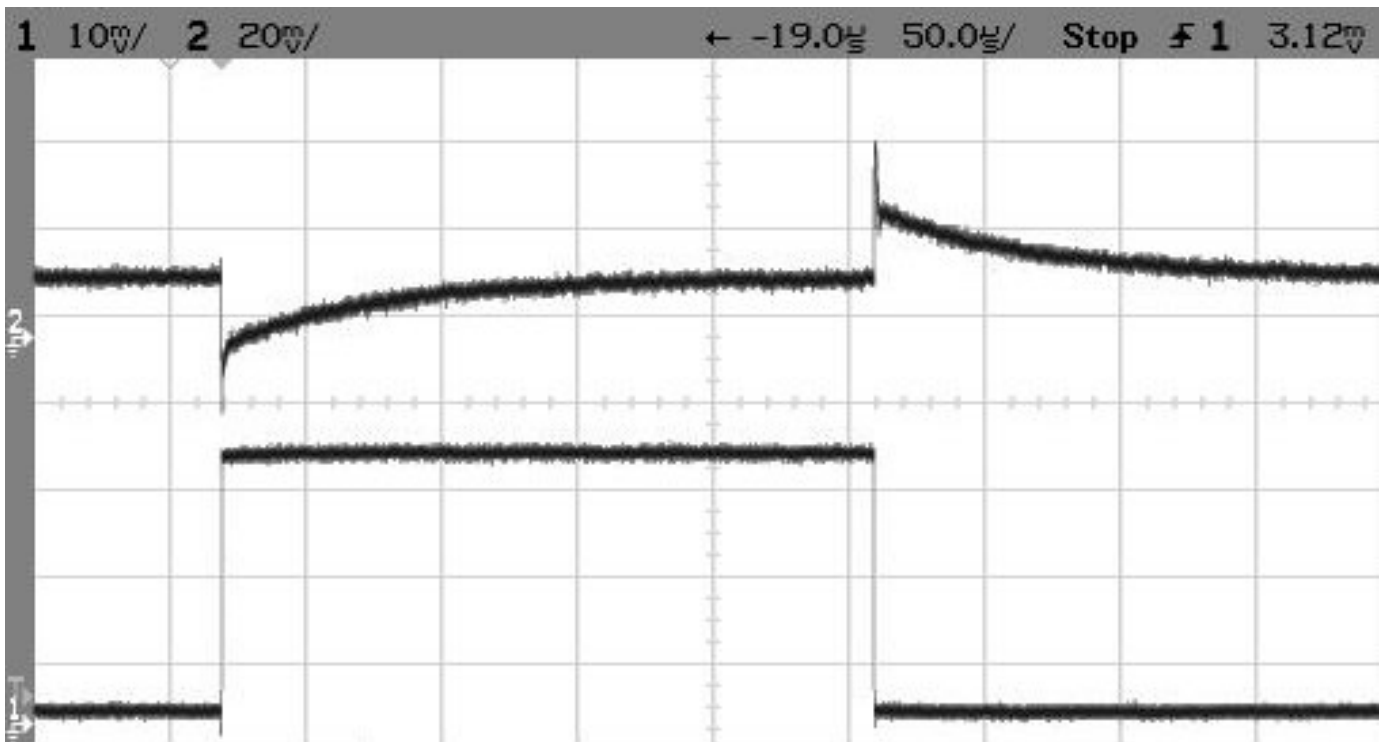

LTC3025 Load-Step Response

This circuit is proprietary to Linear Technology and is not to be used for use with Linear Technology products. While this circuit may be used to design a circuit that meets customer requirements, however, it remains the customer's responsibility to ensure proper and reliable operation in the actual application. Any substitution and printed circuit board layout may affect circuit performance or reliability. Contact Applications Engineering for assistance.

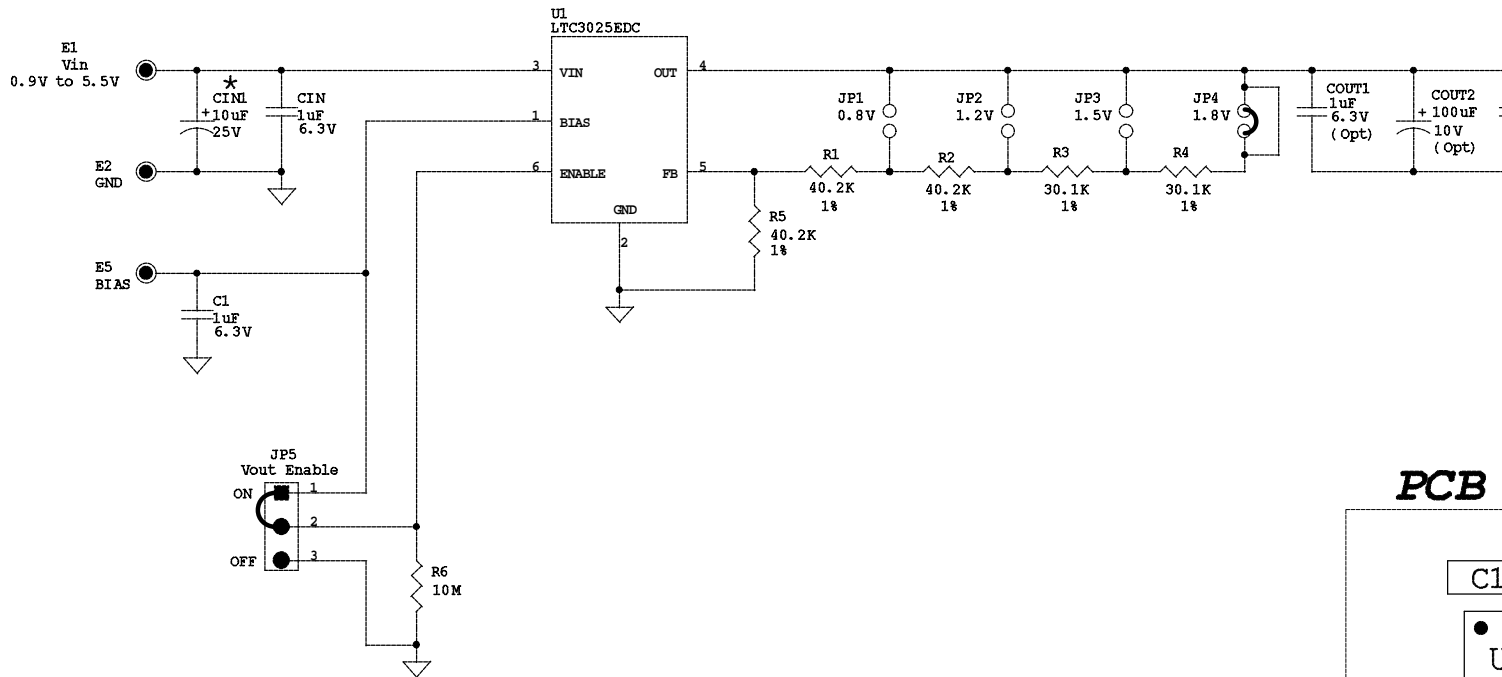

PCB

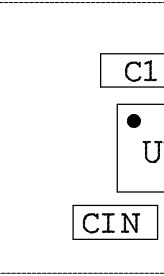

* CIN1 is an optional capacitor. It is inserted on the DC741 to dampen the (possible) ringing voltage due to the use of long input leads. On a normal, typical PCB, with short traces, CIN1 is not needed.

| | | |
|--------------------------------|--------------------------|---------------------|
| Linear Technology Corp. | | 1630 9500 Pho |
| Title: VLDO Linea | | |
| Size | Document Number | Demo |
| Date: | Wednesday, September 29, | |

| Item | Qty | Reference | Part Description | Manufacture / Part # |
|------|-----|-------------------|-----------------------------|---------------------------------|
| 1 | 3 | C1,COUT,CIN | Cap., X5R 1uF 6.3V 20% | TDK C1005X5R0J105M |
| 2 | 1 | CIN1 | Cap., Tant. 10uF 25V 20% | AVX TAJW106M025R |
| 3 | 0 | COUT1 (Opt) | Cap., X5R 1uF 6.3V 20% | TDK C1005X5R0J105M |
| 4 | 0 | COUT2 (Opt) | Cap., Tant. 100uF 10V 20% | AVX TPSD107M010R0100 |
| 5 | 6 | E1,E2,E3,E4,E5,E6 | Testpoint, Turret | Mill Max 2501-2 |
| 6 | 4 | JP1,JP2,JP3,JP4 | Jumper, 2pins 2mm Ctrs. | CommConn Con Inc. 2802S-02G2 |
| 7 | 1 | JP5 | Headers, 3 Pins 2mm Ctrs. | CommConn Con Inc. 2802S-03G2 |
| 8 | 2 | XJP4,XJP5 | SHUNT, .079" CENTER | CommConn Con Inc. CCIJ2MM-138GW |
| 9 | 3 | R1,R2,R5 | Res., Chip 40.2K 1/16W 1% | AAC CR05-4022FM |
| 10 | 2 | R3,R4 | Res., Chip 30.1K 0.06W 1% | AAC CR05-3012FM |
| 11 | 1 | R6 | Res., Chip 10M 1/16W 5% | AAC CR05-106JM |
| 12 | 1 | U1 | I.C., VLDO Linear Regulator | Linear Tech. Corp. LTC3025EDC |
| 13 | 1 | | PRINTED CIRCUIT BOARD | DEMO CIRCUIT 741A |
| 14 | 2 | | STENCIL | STENCIL DC741A |