

DESCRIPTION

Demonstration circuit 901A features the LTC3444 and is a highly efficient, 1.5MHz fixed frequency buck-boost DC/DC converter. The input voltage can range from 3.1V to 5.0V and is suitable for Li-Ion or three-cell NiCd/NiMH battery applications while the output voltage can be set anywhere from 0.8V to 4.2V by injecting a 0.35V – 2.4V Control Signal.

The DC901A has been optimized for use in 3G WCDMA applications. High efficiency is achieved at very low out-

put voltages while component count is minimized. The board provides the fast transient response required to slew the RF power amplifier from standby to transmit and transmit to standby levels. Output overvoltage protection protects the RF power amplifier.

Design files for this circuit board are available. Call the LTC factory.

QUICK START PROCEDURE

Refer to Figure 1 for proper measurement equipment setup and follow the procedure below:

1. Start with Load set to 0A.

2. Set Power Supply 1 to 3.3V and Power Supply 2 to 1V.

3. The Load can be set from 0 – 400mA.

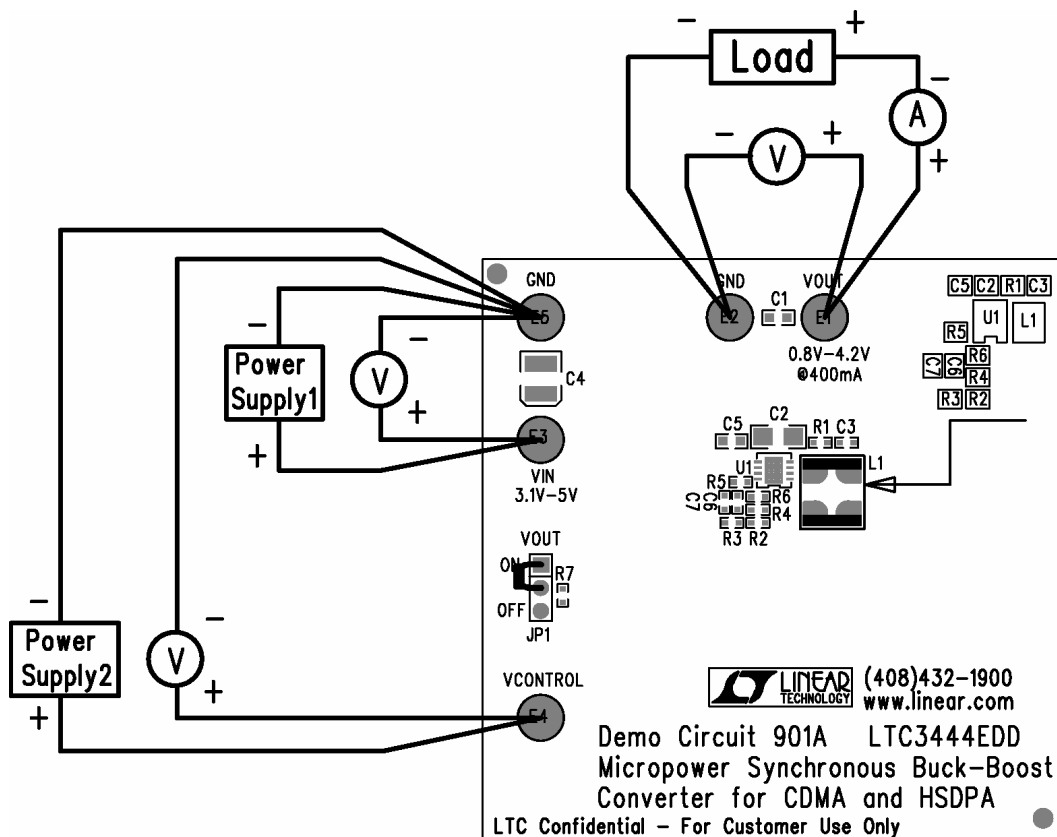

Figure 1. Proper Measurement Equipment Setup

QUICK START GUIDE FOR DEMONSTRATION CIRCUIT 901

MICROPOWER SYNCHRONOUS BUCK-BOOST CONVERTER FOR CDMA AND HSDPA

Demo Board Parameters:

Parameter	Condition	Value
Input Voltage Range		3.1V – 5.0V
Maximum Load Current	Vout = 0.8V – 4.2V	400mA
VCONTROL Range		0.35V – 2.4V*
Operating Frequency		1.5MHz

* See Table 1 in LTC3444 Datasheet.

QUICK START GUIDE FOR DEMONSTRATION CIRCUIT 901 MICROPOWER SYNCHRONOUS BUCK-BOOST CONVERTER FOR CDMA AND HSDPA

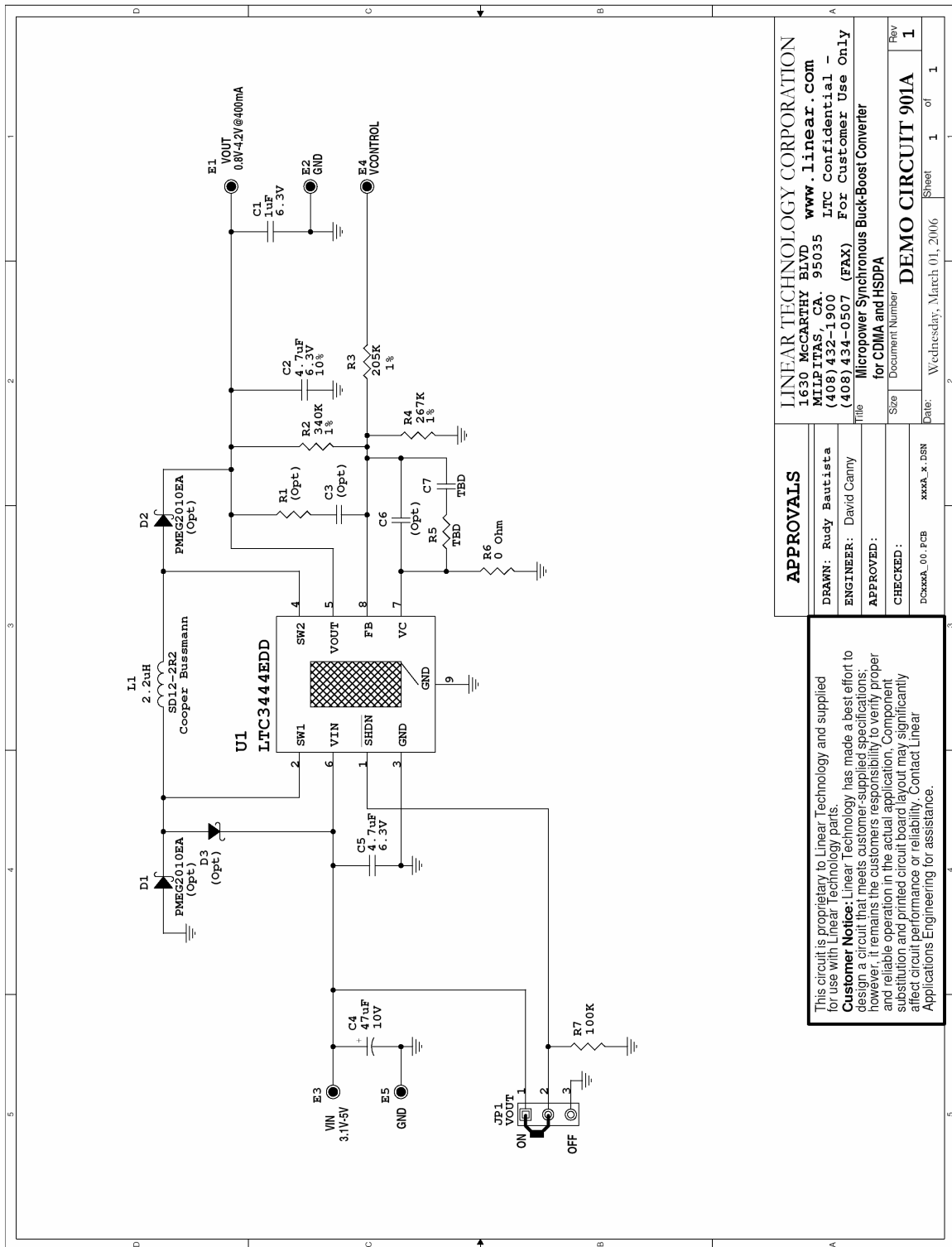

APPROVALS	
DRAWN: Rudy Bautista	www.linear.com
ENGINEER: David Canny	LTC Confidential -
APPROVED:	(408) 432-1900 For Customer Use Only
CHECKED:	(408) 434-0507 (FAX) For Customer Use Only
DCxxxA_00_PCB	Micropower Synchronous Buck-Boost Converter for CDMA and HSDPA
xxxx_x.DSN	Document Number
1	Rev
1	Sheet
1	of
1	1

This circuit is proprietary to Linear Technology and supplied for use with Linear Technology parts.
Customer Notice: Linear Technology has made a best effort to design a circuit that meets customer-supplied specifications; however, it remains the customer's responsibility to verify proper and reliable operation in the actual application. Component substitution and printed circuit board layout may significantly affect circuit performance or reliability. Contact Linear Applications Engineering for assistance.

LINEAR TECHNOLOGY CORPORATION
 1630 MCCARTHY BLVD
 MILPITAS, CA. 95035
 (408) 432-1900
 (408) 434-0507 (FAX)
 www.linear.com
 LTC Confidential -
 For Customer Use Only
 Micropower Synchronous Buck-Boost Converter
 Document Number
DEMO CIRCUIT 901A
 Rev
 1
 Sheet
 1
 of
 1
 Date: Wednesday, March 01, 2006

QUICK START GUIDE FOR DEMONSTRATION CIRCUIT 901

MICROPOWER SYNCHRONOUS BUCK-BOOST CONVERTER FOR CDMA AND HSDPA

REQUIRED CIRCUIT COMPONENTS				
Item	Quantity	Ref. Desig.	Part Description	
1	1	C1	Cap., X5R 1uF 6.3V 10%	Taiyo Yuden JMK107BJ105KA-T
2	1	C2	Cap., X5R 4.7uF 6.3V 10%	TDK C2012X5R0J475K
3	1	C4	Cap., Tant. 47uF 10V 20%	AVX TAJB476M010
4	1	C5	Cap., X5R 4.7uF 6.3V 20%	Taiyo Yuden JMK107BJ475MA-T
5	1	L1	Inductor, 2.2uH	Cooper Bussmann SD12-2R2
6	1	R2	Res., Chip 340K 1/16W 1%	AAC CR05-3403FM
7	1	R3	Res., Chip 205K 1/16W 1%	AAC CR05-2053FM
8	1	R4	Res., Chip 267K 1/16W 1%	AAC CR05-2673FM
9	1	R6	Res/Jumper, Chip 0 Ohm 0.06W 1 AMP	AAC CJ05-000M
10	1	R7	Res., Chip 100K 0.06W 5%	AAC CR05-104JM
11	1	U1	I.C., Buck-Boost Converter	Linear Tech. Corp. LTC3444EDD
ADDITIONAL DEMO BOARD CIRCUIT COMPONENTS				
1	0	C3,C6,C7	Cap., 0402 TBD	
2	0	D1,D2	Schottky Diodes, 1A/20V	Philips PMEG2010EA
3	0	D3	POWERMITE, Case 457	ON Semi.
4	0	R5,R1	Res., 0402 TBD	
HARDWARE FOR DEMO BOARD ONLY				
1	5	E1,E2,E3,E4,E5	Turret, Testpoint	Mill Max 2501-2
2	1	JP1	Headers, 3 Pins 2mm Ctrs.	CommConn Con Inc. 2802S-03G2
3	1	XJP1	Shunt, 2mm Ctrs.	CommConn Con Inc. CCIJ2MM-138G