

## LOW QUIESCENT CURRENT, DUAL OUTPUT HIGH VOLTAGE STEP-DOWN CONVERTER

### DESCRIPTION

Demonstration circuit 1244 is a Low Quiescent Current, Dual Output Synchronous Buck Converter featuring the LTC3890EGN-1. DC1244 converts a 4.5V-60V voltage source to 3.3V at 5.0A and 8.5V at 3.0A. When the input voltage is close or below 9V, 8.5V output enters into dropout mode.

The main features of the board include an external 5V linear regulator for bias, RUN1, RUN2, PGOOD1 pins and a Mode selector that allows converter to run in CCM or Burst Mode operation. DC1244 supports also Pulse Skipping Mode, adjustable output voltage, Soft-Start and Tracking. Synchronization to an external clock is possible as well. The wide input voltage range of 4.5V to 60V is suitable for automotive or other battery fed application and Distributed DC Power Systems where low quiescent current is important.

The LTC3890EGN-1 datasheet gives a complete description of these parts, operation and application informa-

tion. The datasheets must be read in conjunction with this quick start guide for demo circuit 1244.

The 60V avalanche rated MOSFETs, which are used on DC1244, can be operated at their rated voltage. However, if application derating requirements are stricter, MOSFETs with higher voltage rating can be used. Please note, MOSFETs with higher voltage ratings may affect the efficiency. If 60V MOSFETs are used, keep in mind that avalanche rating and testing is typically done with 30% over voltage margin (78V for 60V rated MOSFET). Please check with particular MOSFET manufacturer to ensure the avalanche voltage rating.

**Design files for this circuit board are available. Call the LTC factory.**

 , LTC, LTM, LT are registered trademarks of Linear Technology Corporation.

PARAMETER	CONDITIONS	VALUE	UNITS
Minimum Input Supply Voltage		4.5	V
Maximum Input Supply Voltage		60	V
Output Voltage Range (VOUT1)	VIN = 4.5V to 60V, IOU1 = 0A to 5A	3.3±2%	V
Output Voltage Range (VOUT2)	VIN = 9V to 60V, IOU2 = 0A to 3A	8.5±2%	V
Typical switching frequency		225	kHz
Typical Output Ripple (VOUT1, 3.3V)	I <sub>LOAD</sub> = 5.0A	40	mV
Typical Output Ripple (VOUT2, 8.5V)	I <sub>LOAD</sub> = 3.0A	60	mV
Efficiency Typical (VOUT1, 3.3V)	VOUT1 is ON, VOUT2 is OFF	92	%
Efficiency Typical (VOUT2, 8.5V)	VOUT1 is OFF, VOUT2 is ON	96	%

## QUICK START PROCEDURE

Demonstration circuit 1244 is easy to set up to evaluate the performance of the LTC3890EGN-1. Refer to Figure 1 for proper measurement equipment setup and follow the procedure below:

**NOTE.** When measuring the input or output voltage ripple, care must be taken to avoid a long ground lead on the oscilloscope probe. Measure the input or output voltage ripple by touching the probe tip directly across the VIN or VOUT and GND terminals. See Figure 2 for proper scope probe technique.

1. Place jumpers in the following positions:

**JP4** RUN1 ON,

**JP3** RUN2 ON,

2. With power off, connect the input power supply to VIN and GND.

3. Turn on the power at the input. Check for the proper output voltages  
 $V_{OUT1} = 3.23V$  to  $3.37V$ ,  
 $V_{OUT2} = 8.33V$  to  $8.67V$

**NOTE.** If there is no output, temporarily disconnect the load to make sure that the load is not set too high.

4. Once the proper output voltages are established, adjust the loads within the operating range and observe the output voltage regulation, ripple voltage, efficiency and other parameters.

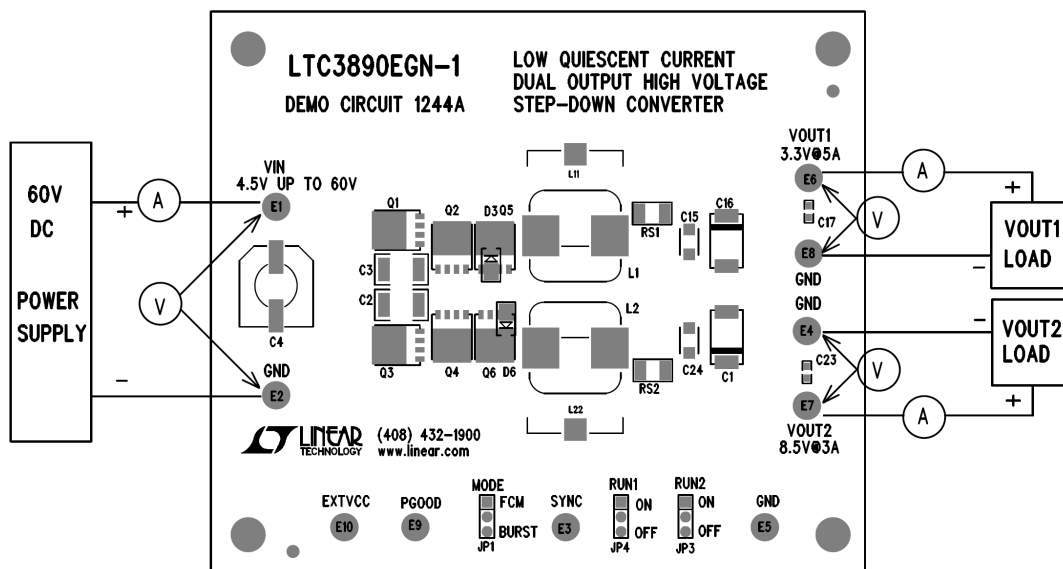

Figure 1. Proper Measurement Equipment Setup

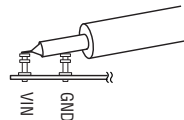

Figure 2. Measuring Input or output Ripple

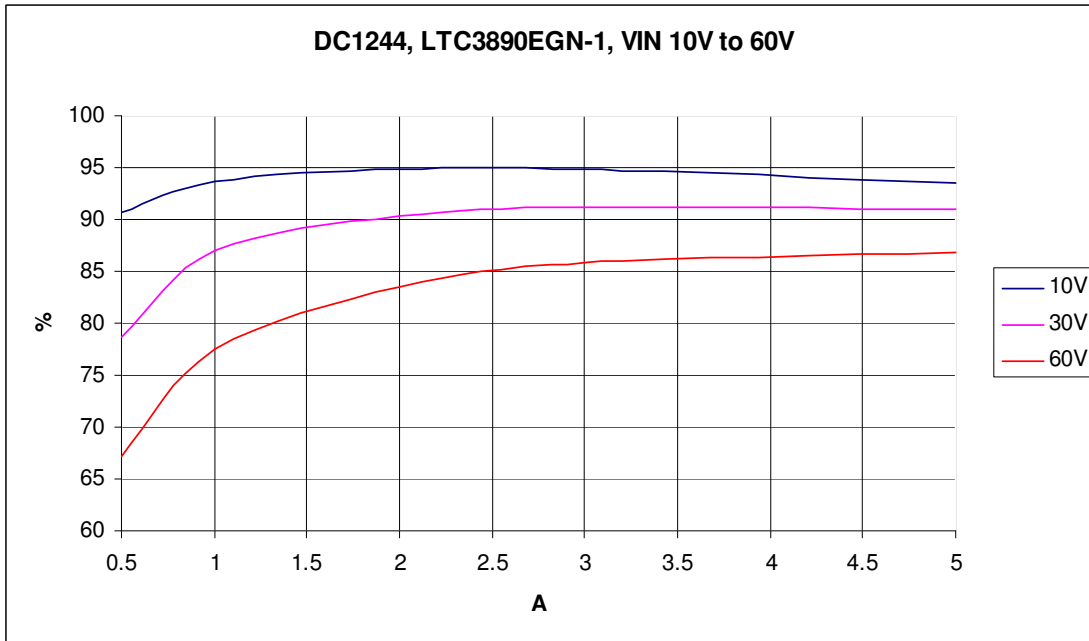

Figure 3. 3.3V Output, Efficiency vs. Load

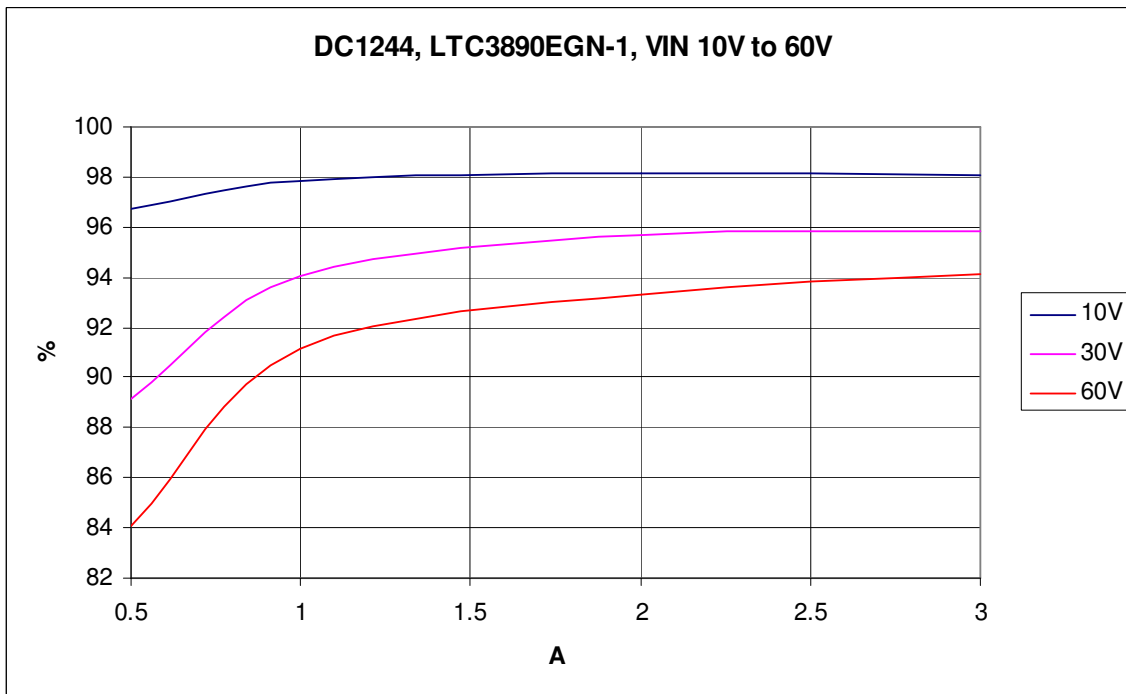
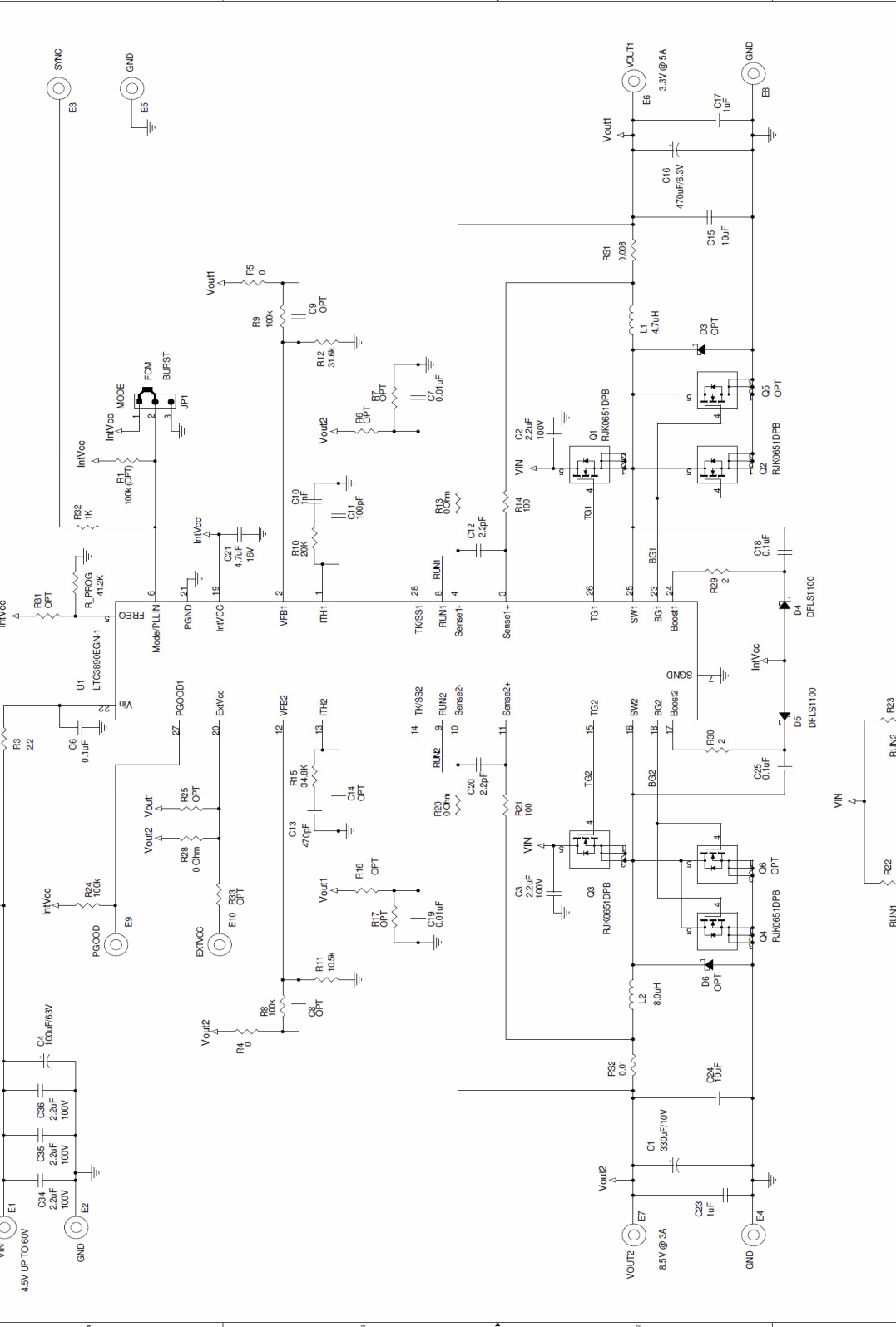

Figure 4. 8.5V Output, Efficiency vs. Load

REVISION HISTORY		
ECC	REV	DESCRIPTION
	4	PRODUCTION
		APPROVED
		DATE
		VICTOR KH
		10/5/08



CUSTOMER NOTICE	
LINEAR TECHNOLOGY HAS MADE A BEST EFFORT TO DESIGN A CIRCUIT THAT MEETS CUSTOMER SUPPLIED SPECIFICATIONS. HOWEVER, IT REMAINS THE CUSTOMER'S RESPONSIBILITY TO VERIFY PROPER AND RELIABLE OPERATION IN THE ACTUAL APPLICATION. COMPONENT SUBSTITUTION AND PRINTED BOARD CHANGES MAY AFFECT CIRCUIT PERFORMANCE OR RELIABILITY. CONTACT LINEAR TECHNOLOGY APPLICATIONS ENGINEERING FOR ASSISTANCE.	
THIS CIRCUIT IS PROPRIETARY TO LINEAR TECHNOLOGY AND SUPPLIED FOR USE WITH LINEAR TECHNOLOGY PARTS.	

CONTRACT NO.	APPROVALS
	POB DELAY/ONM/K
	ENG. VICTOR KH
TITLE: SCHEMATIC LOW QUIESCIENT CURRENT DUAL OUTPUT HIGH VOLTAGE STEP-DOWN CONVERTER	
SIZE	IC NO.
A	LTC3890EGN-1
REV	DEMO CIRCUIT 1244A
4	
DATE:	Wednesday, March 03, 2010
SHEET	1 OF 1

NOTE: FOR SKIP MODE OPERATION INSTALL R1 AND REMOVE JP1