

(Standard detection type)

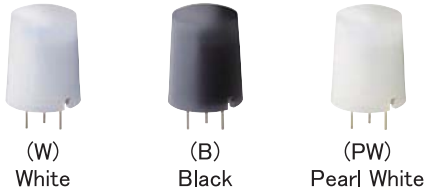

(Long distance detection type)

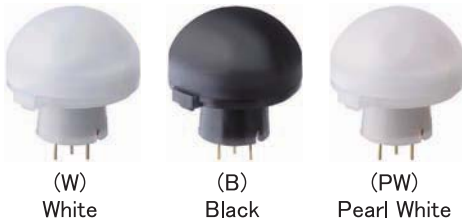

- 1. 1 μ A low current consumption with Panasonic's proprietary design**

Development of a specialized circuit allows the reduction of current consumption to 1 μ A (during sleep mode). When motion is detected, the sensor will shift to "standby" mode.

Reduction of current consumption allows battery life to be extended for battery driven products, including wireless based and low power consumption devices. (Product lineup includes 1 μ A, 2 μ A, and 6 μ A sensors.)
- 2. Simplified circuitry with fully integrated sensor design**

Panasonic's proprietary high-density embedded circuit design eliminates external sensing circuits. Advantages include reduced development and design schedules.
- 3. Lead-free pyroelectric elements**

PaPIRS sensing elements contain lithium tantalate and are lead-free. Typical PIR sensing elements are ferroelectric ceramic (PZT) containing lead.
- 4. Low curvature lens for product designs**

Panasonic's lens formation technology achieves a semi-flat lens with a smooth surface and minimum protrusion from the device (lens diameter: ϕ 9.5mm).

In addition to white and black lens options, pearl white is offered for design aesthetics. (※Refer to "Dimensions" on page 5)
- 5. Robust design prevents false detection**

PaPIRS sensing circuits are enclosed in a metallic can to minimize adverse effects of external electromagnetic fields. Examples include radiated noise caused by cellular phones.

A high S/N ratio minimizes sensitivity to false tripping when operated under various environmental conditions.

APPLICATIONS

Security Equipment:

- Wireless security sensors, and cameras.

Wireless Devices / Mobile Equipment:

- Wireless occupancy sensors (powered by PV cells or battery)
- PC and smart phone

What is passive infrared type?

This sensor detects changes in infrared radiation which occur when there is movement by a person (or object) which is different in temperature from the surroundings.

- ① As this sensor detects temperature differences, it is well suited to detecting the motion of people by their body temperature.
- ② Wide sensing area.

Compliance with RoHS Directive

Block Diagram (Digital output circuit)

Built-in amplifier and comparator connected directly to a microcomputer.

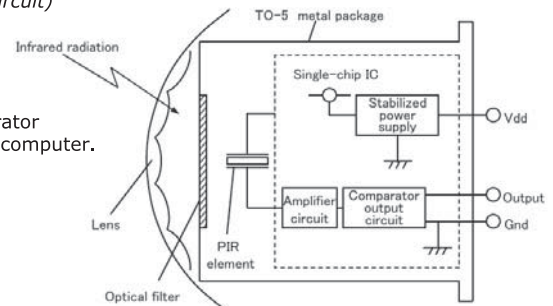

ORDERING INFORMATION

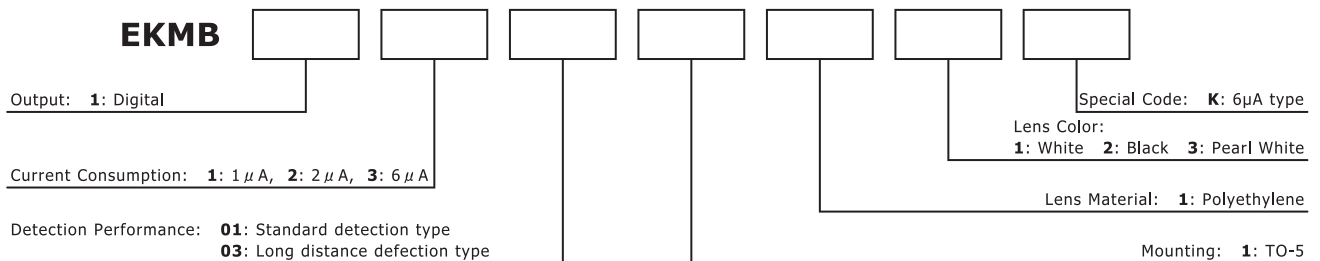

PRODUCT TYPES

Detection Performance	Current Consumption	Lens Color	Model No.	Inner Package	Outer Package
Standard detection type	1 μ A	White	EKMB1101111	50pcs	1000pcs
		Black	EKMB1101112		
		Pearl White	EKMB1101113		
	2 μ A	White	EKMB1201111		
		Black	EKMB1201112		
		Pearl White	EKMB1201113		
	6 μ A	White	EKMB1301111K		
		Black	EKMB1301112K		
		Pearl White	EKMB1301113K		
Long Distance detection type	1 μ A	White	EKMB1103111	50pcs	1000pcs
		Black	EKMB1103112		
		Pearl White	EKMB1103113		
	2 μ A	White	EKMB1203111		
		Black	EKMB1203112		
		Pearl White	EKMB1203113		
	6 μ A	White	EKMB1303111K		
		Black	EKMB1303112K		
		Pearl White	EKMB1303113K		

PERFORMANCE

1. Detection Performance [Conditions for measuring: Ambient temperature : 25°C(77°F) Operating voltage : 3VDC]

Items		Standard Detection type	Long Distance Detection type	Conditions concerning target
Detection Range *1)		Max. 5m	Max. 12m	1. The temperature difference between the target and the surroundings should be superior to 4°C (7.2°F). 2. Movement speed: 1.0m/s 3. Target concept is human body (Size: 700 × 250mm)
Detection Area	Horizontal *2)	94° (±47°)	102° (±51°)	
	Vertical *2)	82° (±41°)	92° (±46°)	
	Detection Zone *3)	64 zones	92 zones	

*1) Depending on the target's speed and temperature difference compared to the surroundings, detection can occur at a range superior to the above value. Please use this sensor according to the specifications for guaranteed performance.

*2) Definitions for "Horizontal" and "Vertical":

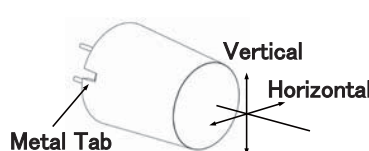

Standard detection type

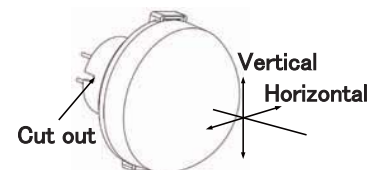

Long Distance detection type

*3) Refer to the "detection area" diagram on P.4.

2. Maximum Rated Values

Items	Specified value
Power Supply Voltage	-0.3~4.5V DC
Usable Ambient Temperature	-20~+60°C (-4~+140°F) Do not use in a freezing or condensation environment.
Storage Temperature	-20~+70°C (-4~+158°F)

3. Electrical Characteristic [Measuring conditions: Ambient temperature 25°C(77°F)]

Items	Symbol	1 μ A type	2 μ A type	6 μ A type	Measured Conditions
Operating Voltage	Min.	2.3V DC	2.3V DC	2.3V DC	—
	Max.	4.0V DC	4.0V DC	4.0V DC	—
Electrical Current Consumption (Sleep mode) (*4)	Avg.	1.0 μ A	—	—	Iout=0
	Max.	1.6 μ A	—	—	
Electrical Current Consumption (Standby mode) (*4)	Avg.	1.9 μ A	1.9 μ A	6.0 μ A	Iout=0
	Max.	3.0 μ A	3.0 μ A	12.0 μ A	
Output Current	Max.	Iout	100 μ A	100 μ A	Vout \geq Vdd-0.5
Output Voltage	Min.	Vout	Vdd-0.5VDC	Vdd-0.5VDC	Vdd-0.5VDC
Circuit Stability Time (When voltage is applied)	Avg.	Twu	25s	25s	—
	Max.	Twu	210s	210s	10s (*6)

(*4)(*5) : "Sleep mode" or "Standby mode" is for 1 μ A current consumption version. Please refer to "TIMING CHART" below.

(*6) : This is when temperature of the sensor is stable.

TIMING CHART

1. Digital output (1 μ A current consumption)

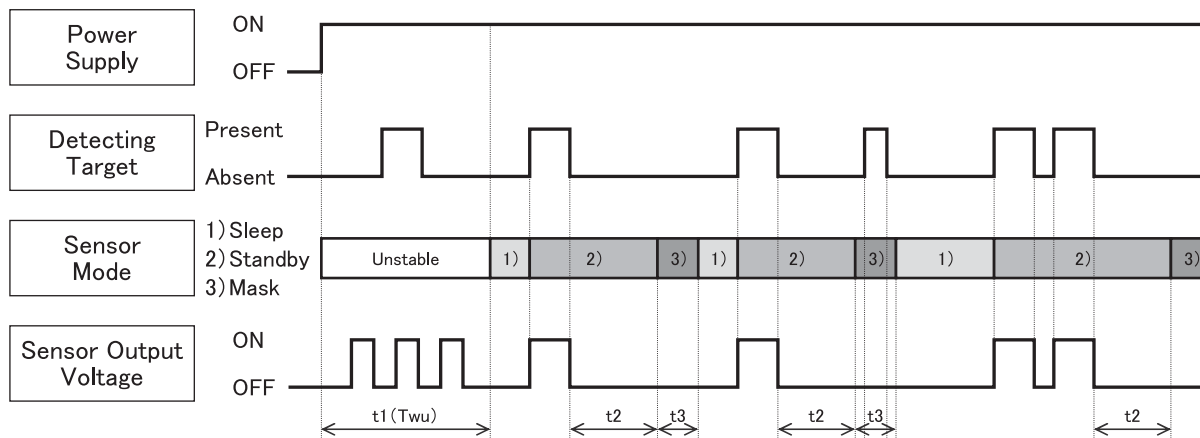

[Modes]

- 1) Sleep Mode : When the output is OFF. The electrical current consumption is approximately 1 μ A.
- 2) Standby Mode : After the sensor's output reaches ON status, the sensor switches to standby mode. The electrical current consumption is ~ 1.9 μ A. When the sensor's output returns to an OFF value after expiration of the "hold time", the sensor switches again to sleep mode.
- 3) Mask Mode : Time during which the output is forced to OFF after the end of the standby mode. (no detection is possible during this period.)

[Durations]

- t1(Twu): Circuit Stability Time: ~ 25s (typ.)
During this stage, the output's status is undefined (ON/OFF) and detection is not guaranteed.
- t2 : Standby Hold Time: ~ 2.6s (typ.)
Depending on the number of output occurrences during standby mode, the hold time can differ (※1)
- t3 : Mask Time ~ 1.3s (typ.)
During this stage, even if the sensor detects something, output will not switch ON.(※2)

2. Digital Output (2 μ A and 6 μ A current consumption)

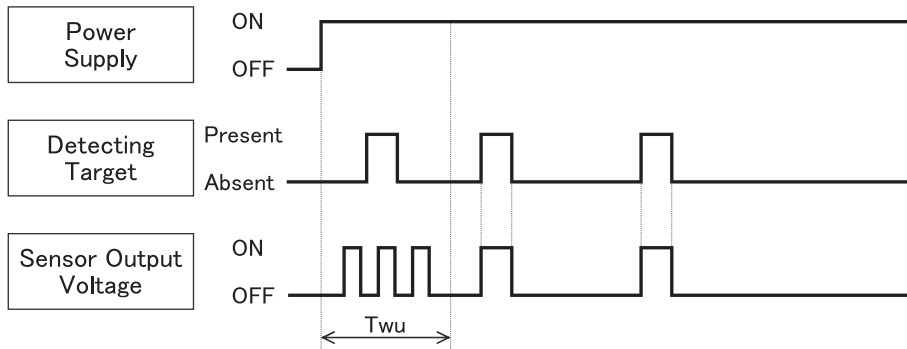

[Durations]

T_{wu} : Circuit Stability Time (2 μ A): \sim 25s (typ.)
 Circuit Stability Time (6 μ A): \sim 10s (max.)
 During this stage, output status is undefined (ON/OFF) and detection is not guaranteed.

DETECTION PERFORMANCE

1) Standard detection type

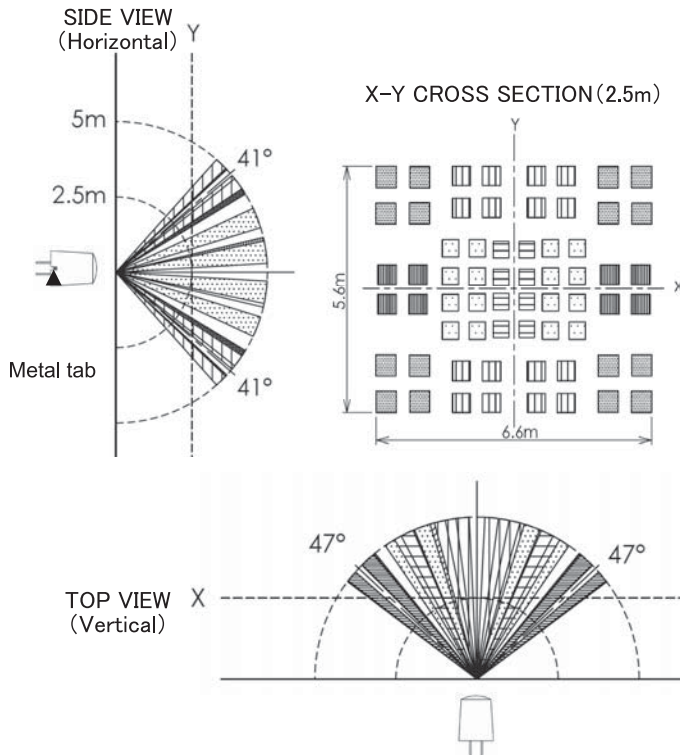

2) Long Distance detection type

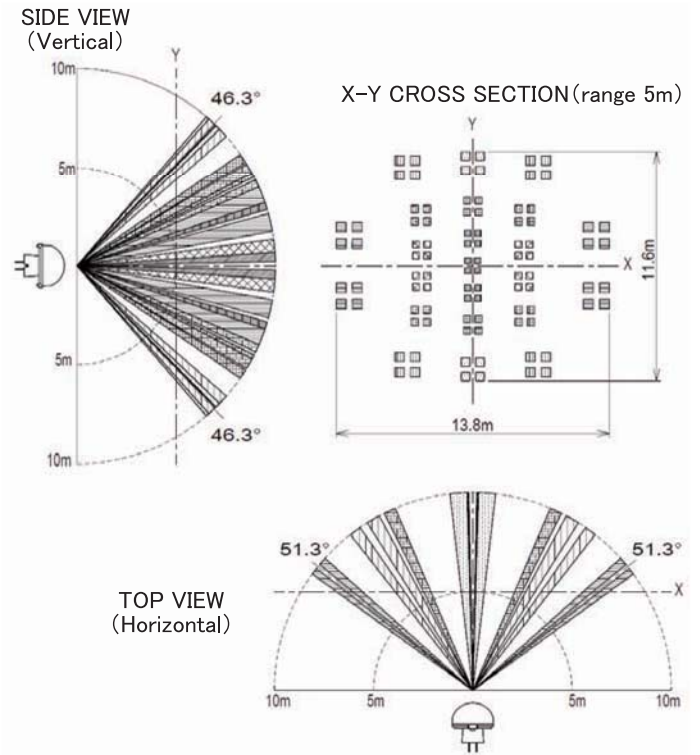

2. Detection Zone Notes

As shown on the diagram, the detection zone is polarized. If a target enters the detection zones + and - at the same time, the signals are respectively cancelled and detection could become impossible at maximum detection range. (Please refer to the detection area diagram for details)

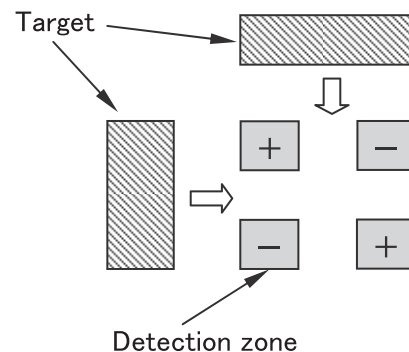

HOW TO USE

1. Wiring Diagram (Digital Output)

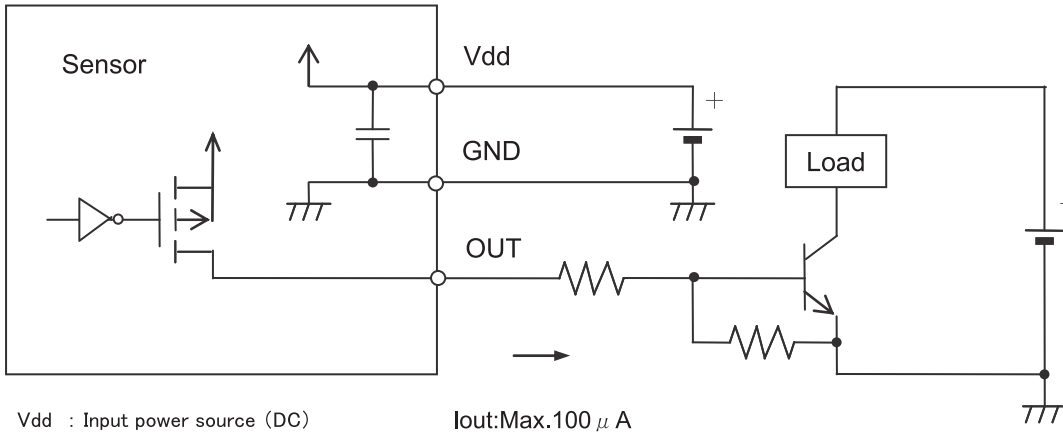

Vdd : Input power source (DC)
 GND : GND
 Out : Output (Comparator)

I_{out}:Max.100 μ A

2. Moving Direction

As detailed on the diagram, please install the sensor so that the expected trespassing direction corresponds to the axis X or axis Y.

In some cases, intrusions that occur parallel to the axis Z in every detection zone, closing toward the sensor, may not be detected.

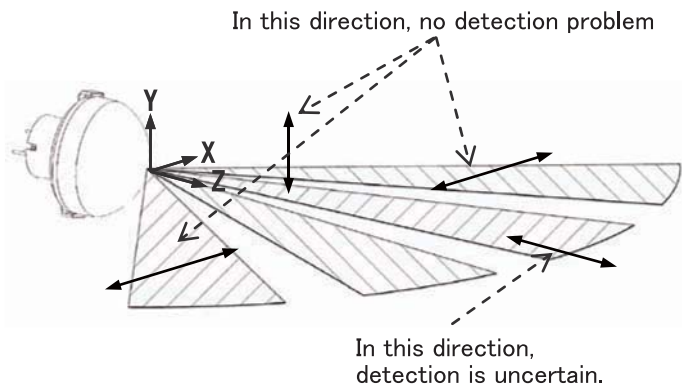
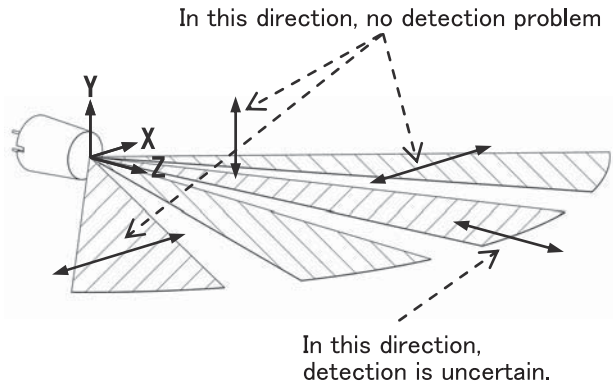

DIMENSION

1) Standard Detection type



White



Black



Pearl White

A-A Cross Sectional

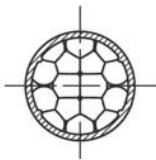

Dimensions

TOP VIEW



SIDE VIEW

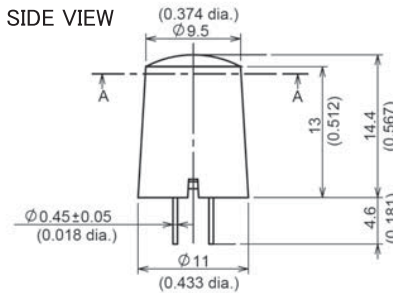

BOTTOM VIEW

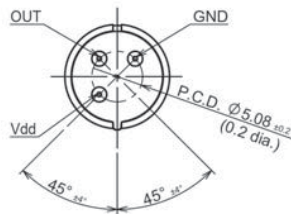

When designing your products

To maintain specified detection capability, position the sensor so that the lens tip is a minimum 1.3mm above the chassis.

The chassis hole requires a taper according to the lens shape, or a larger hole.

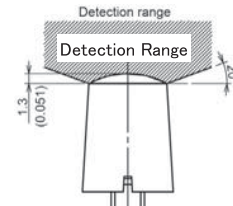

Recommended Hole Drilling Diameter

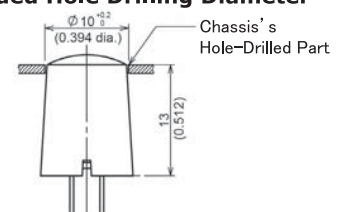

Recommended PCB Pattern Design

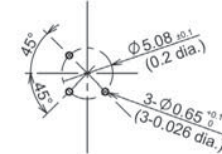

2) Long Distance Detection type



White



Black



Pearl White

A-A Cross Sectional

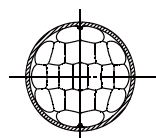

Dimensions

TOP VIEW

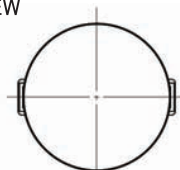

SIDE VIEW

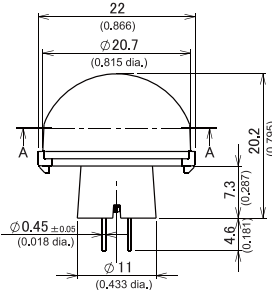

BOTTOM VIEW

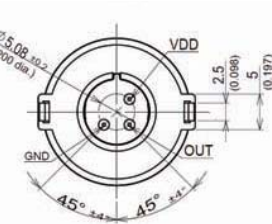

When designing your products

To maintain specified detection capability, please place and expose the sensor so that tip of lens will be more than 7.1mm above the chassis.

The hole of the chassis should have a taper depending on the lens shape, or have a bigger hole.

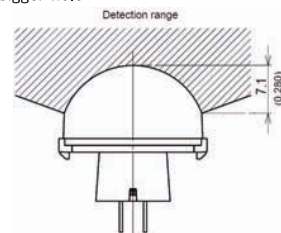

Recommended Hole Drilling Diameter

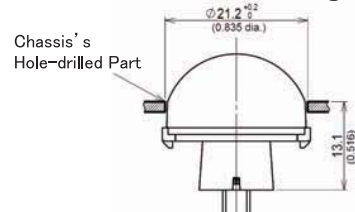

Recommended PCB Pattern Design

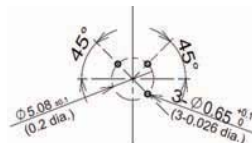

General Tolerance ±0.5mm (±0.020inch)

NOTES

1. Basic Principles

The PaPIRS Motion Sensor is a pyroelectric infrared sensor that detects variations in infrared rays. However it may not detect in the following cases: lack of movement, no temperature change in the heat source. Besides, it could also detect the presence of heat sources other than a human body. Efficiency and reliability of the system may vary depending on actual operating conditions:

- 1) Detecting heat sources other than the human body, such as:
 - a) small animals entering the detection area.
 - b) white light source (sunlight, car headlights, etc.) directly hitting the sensor.
 - c) sudden temperature changes in the detection area caused by humidifier water vapor emission, or air conditioning system hot/cold air emissions.
- 2) Difficulty in sensing the heat source
 - a) Glass, acrylic or similar materials standing between the target and the sensor may not allow a correct transmission of infrared rays.
 - b) Non-movement or quick movements of the heat source inside the detection area.
- 3) Expansion of the detection area
In case of considerable difference in the ambient temperature and the human body temperature, detection area may be wider apart from the configured detection area.

3. Ambient Environmental Conditions

- 1) Temperature: Ambient temperature $-20^{\circ}\text{C} \sim +60^{\circ}\text{C}$ ($-4^{\circ}\text{F} \sim +140^{\circ}\text{F}$)
(Do not use in a freezing or condensation environment)
Storage Temperature $-20^{\circ}\text{C} \sim +70^{\circ}\text{C}$ ($-4^{\circ}\text{F} \sim +158^{\circ}\text{F}$)
- 2) Humidity Degree: 15~85% Rh (Avoid condensation or freezing of this product)
- 3) Pressure : 86~106kPa
- 4) Operating “temperatures” and “humidity level” are suggested to prolong usage. However, they do not guarantee durability or environmental resistance. Generally, high temperatures or high humidity levels will accelerate the deterioration of electrical components. Please consider both the planned usage and environment to determine the expected reliability and length of life of the product.
- 5) This sensor is not waterproof or dustproof. Avoid use in environments subject to excessive moisture, condensation, frost, containing salt air or dust. If a sensor is used with a cover installed, the initial detection performance specifications may not be able to be met. Confirm the operation under the actual operating conditions.
- 6) Overheating, oscillations, shocks can cause the sensor to malfunction.

2. Other handling cautions

- 1) Deterioration of detecting performance will happen if dirt and dust adhere to the lens.
- 2) The lens of the Polyethylene lens type is made of soft materials (Polyethylene). If any loads or shocks are applied to the lens, due to deformities, and damages, this will lead to malfunction, or deterioration of performance.
- 3) The sensor may be damaged by ± 200 volts of static electricity. Avoid direct hand contact with the pins and be very careful when operating the product
- 4) When soldering the lead wire, hand solder the sensor using the soldering iron below 350°C , and within 3 seconds. Please avoid soldering using solder tank, this can lead to deterioration of performance. Also please avoid bending the lead wire to mount the sensor on to the circuit board temporarily. This will damage the sensor.
- 5) Do not use liquids to wash the sensor. If washing fluid gets through the lens, it can reduce performance.
- 6) When wiring the product, always use shielded cables and minimize the wiring length to prevent noise disturbances.

4. External surge voltages

The inner circuit board could be destroyed by a voltage surge. Use of surge absorption elements is highly recommended.
>Surge resistance : below the power supply voltage value indicated in the maximum rated values section.

5. Power supply-superimposed noise

- 1) Please use a stabilized power supply. Power supply noise can cause operating errors.
>Noise resistance : $\pm 20\text{V}$ or less (Square waves with a width of 50ns or $1 \mu\text{s}$)
- 2) To reduce the effect of power supply noise, install a capacitor on the sensor's power supply pin.

6. Drop damage

After the sensor had been dropped on the floor, the damage can occur resulting in incorrect operation. Therefore, be sure not to use those sensors.

**Safety Precautions**

Head the following precautions to prevent injury or accidents.

- 1) Do not use these sensors under any circumstance in which the range of their ratings, environment conditions or other specifications are exceeded. Using the sensors in any way which causes their specifications to be exceeded may generate abnormally high levels of heat, emit smoke, etc., resulting in damage to the circuitry and possibly causing an accident.
- 2) Our company is committed to making products of the highest quality and reliability. Nevertheless, all electrical components are subject to natural deterioration, and durability of a product will depend on the operating environment and conditions of use. Continued use after such deterioration could lead to overheating, smoke or fire. Always use the product in conjunction with proper fire-prevention, safety and maintenance measures to avoid accidents, reduction in product life expectancy or break-down.
- 3) Before connecting, check the pin layout by referring to the connector wiring diagram, specifications diagram, etc., to verify that the connector is connected properly. Mistakes made in connection may cause unforeseen problems in operation, generate abnormally high levels of heat, emit smoke, etc., resulting in damage to the circuitry.
- 4) Do not use any motion sensor which has been disassembled or remodeled.
- 5) Failure modes of sensors include short-circuiting, open-circuiting and temperature rises. If this sensor is to be used in equipment where safety is a prime consideration, examine the possible effects of these failures on the equipment concerned, and ensure safety by providing protection circuits or protection devices.
Example :
 - Safety equipments and devices
 - Traffic signals
 - Burglar and disaster prevention