

LT6109-1/LT6109-2 High Side Current Sense Amplifiers with Reference and Comparators

DESCRIPTION

Demonstration circuit 1659A features the LT[®]6109, a high side current sense amplifier with two comparators and a 400mV reference.

The demo board circuit amplifies the voltage across an on-board current sense resistor, to provide a precision unipolar voltage output that is proportional to the sensed current. The board has two on-board comparators with latching outputs and an integrated 400mV reference that sets the threshold for the comparators. There are two versions of this demonstration circuit, A and B, depending on which version of the LT6109 is installed. The DC1659A-A (LT6109-1) has an inverting and a noninverting comparator input available, while the DC1659A-B (LT6109-2) has

two inverting inputs available. Both current sense gain and current fault limits are set by on board resistors and are the same for both boards. The gain is set at 100V/V and the comparators are set to trip at current thresholds of 50mA and 300mA.

The key performance specifications are listed in the table below.

Design files for this circuit board are available at <http://www.linear.com/demo>

LT, LT, LTC, LTM, TimerBlox, Linear Technology and the Linear logo are registered trademarks of Linear Technology Corporation. All other trademarks are the property of their respective owners.

PERFORMANCE SUMMARY (T_A = 25°C)

SYMBOL	PARAMETER	CONDITIONS	MIN	TYP	MAX	UNITS
V _{IN}	Input Supply Range		2.7		60	V
V _{IOUT}	Measured Output Signal	I _{LOAD} = 100mA		1		V
I _{IOUT}	Measured Output Current	V _{IOUT} = 1V		100		μA
I _{LOAD}	Output Load Current Range	Thermal Limit of R _{SENSE}			4	A
I _Q	IN Quiescent Current	V _{IN} = 12V		800		μA
V _{THR1}	Comparator1 Threshold	V _{IOUT} = 3.0V		300		mA
V _{THR2}	Comparator2 Threshold	V _{IOUT} = 0.5V		50		mA

OPERATING PRINCIPLES

The LT6109 operates by amplifying the voltage drop across a sense resistor that is in series with the load. The sense inputs of the amplifier differentially measure the sense resistor voltage drop to control an internal variable current source that allows translation of the input voltage level to a level referenced to the GND. The circuit gain is set by

the ratio of the output resistor to the input resistor. The comparator thresholds are set by the internal reference and the current trip points are set by dividing the output resistance into a network of three resistors. The DC1659 is shipped with a 100mΩ sense resistor, a gain of 100 and current fault thresholds of 50mA and 300mA.

QUICK START PROCEDURE

The DC1659A provides a simple way to evaluate the performance of the LT6109. Refer to Figure 1 for proper measurement equipment setup and follow the procedure below:

1. With the power off, connect the power supply positive to IN and the common to GND. With default board settings the supply can range from 3.3V to 60V. If the supply does not have an accurate current readout, a DMM may be connected in series with the supply as shown in Figure 1.
2. Connect a DMM or oscilloscope to the I_{OUT} with the common connection connected to ground.
3. Connect a load to the demo boards OUT terminal (positive) and ground. The load may be a power resistor, active load instrument or a circuit of interest.

4. Turn on the power supply. The comparators start in an unknown state and must be reset. This can be done by pressing the reset button. With the load shown in Figure 1 the comparator outputs should be:

PART	C _{OUT1}	C _{OUT2}
DC1659A-A LT6109-1	High	High
DC1659A-B LT6109-2	High	Low

5. Measure the output voltage and confirm it corresponds to the load current. $V_{IOUT} = 10 \cdot I_{LOAD}$ for the factory installed resistors.
6. If able, sweep load current from 0mA to 300mA to verify the operation of the comparators. The LED will turn on when the comparator output has latched low. Use the reset circuitry to reset comparator output.

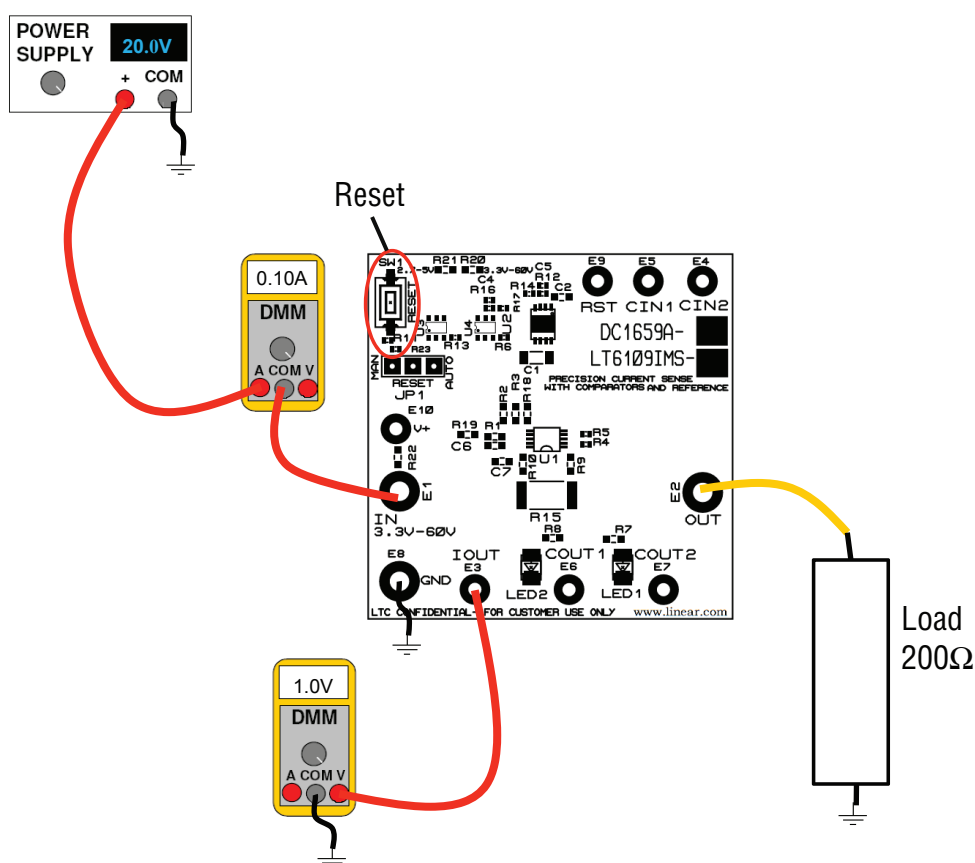

Figure 1. Test Setup

OPERATION

Current Sense Gain

The gain of the LT6109 current sense amplifier is set by the ratio of R_{OUT} and R_{IN} resistors. In the demo circuit this means that the gain is set by the ratio of $(R1 + R2 + R3)/R10$. The gain error is primarily controlled by the precision of the resistors used. The factory resistors are a 1% tolerance which will dominate the gain error. To reduce system gain error, the resistors can be replaced with 0.1% resistors.

LED Indicators

The LEDs indicate the state of the comparator outputs. When the LED is on, the comparator is latched low. When the LED is off, the comparator output is high. When the comparator output is latched low, the LT6109 must be reset to refresh the comparator output and to turn off the LEDs.

Jumper Summary

Reset(JP1): The Reset jumper has two settings for manual or auto mode. In manual mode, the user must press the reset button to reset the latching comparators. In auto mode, the comparators will be continuously reset every 10 seconds. The factory default setting is manual mode.

Optional Settings

1. For supply voltages below 3.3V, remove R20 and install R21 (0 Ω jumper). When R21 is installed, the supply voltage must stay between 2.7V to 6V to prevent damaging the TimerBlox[®] circuitry that is used to reset the comparator outputs.
2. To power the LT6109 from a supply separate from the load, remove R22 and connect the power supply to V⁺ turret.
3. There are a number of optional components that (not installed) allow the DC1659 to be tailored to a specific application:
 - A) To free comparator input INC1, remove R2 and R3 and install R19.
 - B) To free comparator input INC2, remove R1 and R2 and install R18.
 - C) To add filtering to the amplifier output, install C6.
4. R9 can be set to the same value as R10 to reduce error caused by input bias current. Typically for values of R10 (less than 1k) and R9 can be omitted as the error is negligible.

PARTS LIST

ITEM	QTY	REFERENCE	PART DESCRIPTION	MANUFACTURER/PART NUMBER
1	1	C1	Capacitor, 1 μ F 20% 1206 100V X7R	TDK/C3216X7R2A105M
2	1	C2	Capacitor, 0.47 μ F 20% 0603 16V X5R	AVX/0603YD474MAT2A
3	2	C4, C5	Capacitor, 0.1 μ F 20% 0402 10V X5R	Taiyo Yuden/LMK105BJ104MV-F
4	1	C6	Capacitor, 0.1 μ F 20% 0603 X5R Optional	
5	1	C7	Capacitor, 0.1 μ F 10% 0603 100V X7R	Murata/GRM188R72A104KA35D
6	3	E1, E2, E8	Turret Terminal	Mill Max 2501-2-00-80-00-00-07-0
7	7	E3-E7, E9, E10	Turret Terminal	Mill Max 2308-2-00-80-00-00-07-0
8	1	JP1	Header, 3-Pin, 2mm	SAMTEC TMM-103-02-L-S
9	1	JP1	Shunt	SAMTEC 2SN-BK-G
10	2	LED1, LED2	Red1206 LED	Panasonic/LN1251C
11	1	R1	Resistor, 2k 1% 0603 1/16W	AAC/CR16-2001FM
12	1	R2	Resistor, 6.65k 1% 0603 1/16W	Vishay/CRCW06036K65FKEA
13	1	R3	Resistor, 1.33k 1% 0603 1/16W	AAC/CR16-1331FM
14	3	R4, R5, R14	Resistor, 10k 5% 0402 1/16W	AAC/CR05-103JM
15	1	R6	Resistor, 118k 1% 0402 1/16W	AAC/CR05-1243FM
16	2	R7, R8	Resistor, 1k 5% 0603 1/16W	Vishay/CRCW04021K00JNED
17	1	R10	Resistor, 100 Ω 1% 0603 1/16W	Vishay/CRCW0603100RFKEA
18	1	R11, R22	Resistor, 0 Ω 0402 1/16W	Vishay/CRCW04020000Z0ED
19	1	R12	Resistor, 13.7k 1% 0402 1/16W	AAC/CR05-1372FM
20	1	R13	Resistor, 249k 1% 0402 1/16W	AAC/CR05-2493FM
21	1	R15	Resistor, 0.1 Ω 1% 2512 2W	IRC/LR2512LF-01-R100-F
22	1	R16, R23	Resistor, 1M 1% 0402 1/16W	AAC/CR05-1004FM
23	1	R17	Resistor, 392k 1% 0402 1/16W	AAC/CR05-3923FM
24	3	R18, R19, R21	Optional	
25	2	R20, R9	Resistor, 0 Ω 0603 1/16W	AAC/CJ06-000M
26	1	SW1	Switch, Pushbutton	Panasonic/EVQPPDA25
28	1	U2	IC, LT3010EMS8E#PBF	Linear Technology Corp.
29	1	U3	IC, LT6993CS6-1#PBF	Linear Technology Corp.
30	1	U4	IC, LT6991CS6#PBF	Linear Technology Corp.

DC1659A-A

1	1	U1	IC, LT6109IMS-1	Linear Technology Corp. LT6109IMS-2
---	---	----	-----------------	-------------------------------------

DC1659A-B

1	1	U1	IC, LT6109IMS-2	Linear Technology Corp. LT6109IMS-2
---	---	----	-----------------	-------------------------------------

SCHEMATIC DIAGRAM

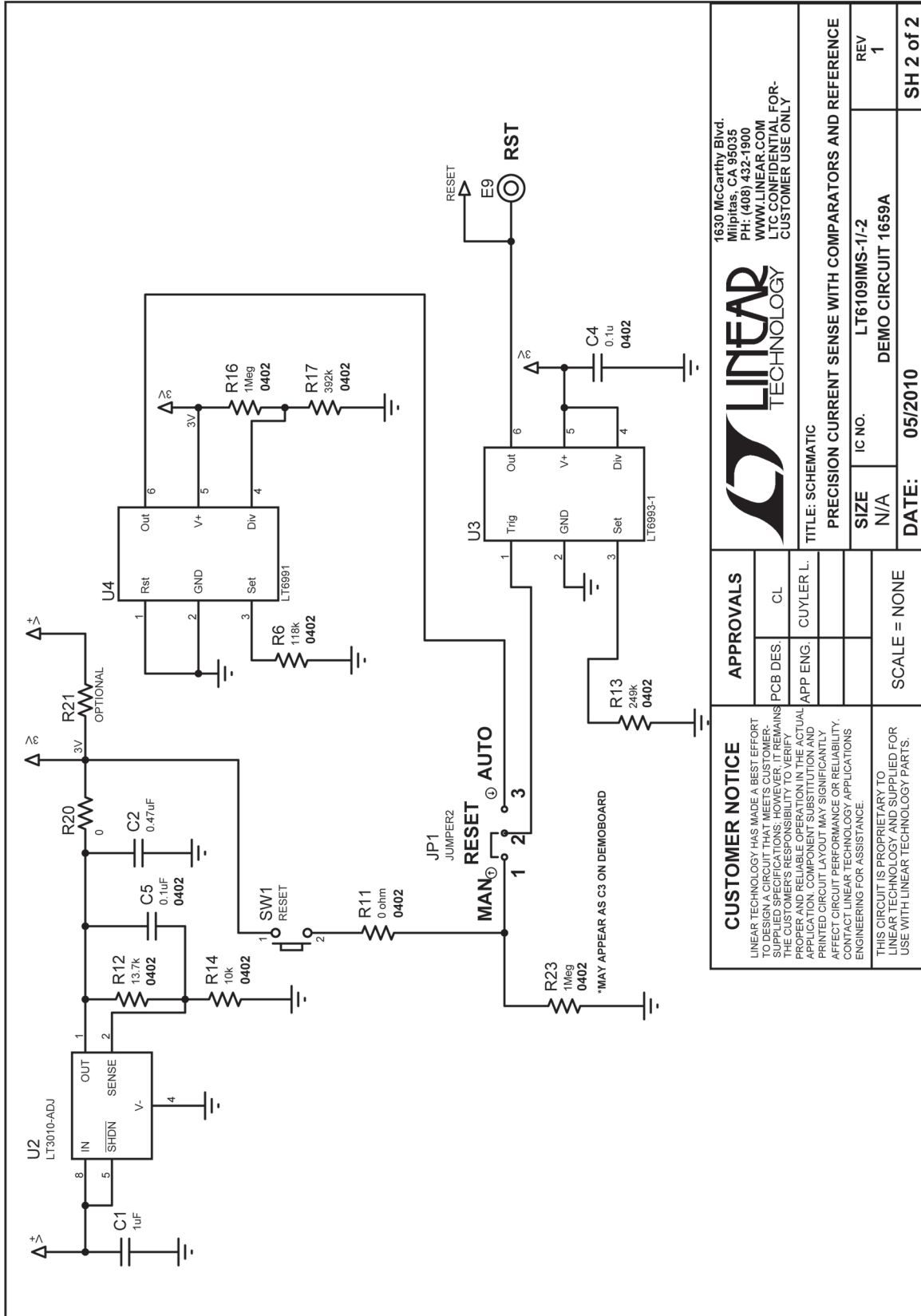

1630 McCarthy Blvd.
Milpitas, CA 95035
PH: (408) 432-1900
WWW.LINEAR.COM
LTC CONFIDENTIAL FOR-
CUSTOMER USE ONLY

LINEAR TECHNOLOGY

TITLE: SCHEMATIC
PRECISION CURRENT SENSE WITH COMPARATORS AND REFERENCE

SIZE	IC NO.	REV
N/A	LT6109IMS-1/-2	1

DATE: 05/2010

DEMO CIRCUIT 1659A

SH 2 of 2

CUSTOMER NOTICE		APPROVALS	
LINEAR TECHNOLOGY HAS MADE A BEST EFFORT TO DESIGN A CIRCUIT THAT MEETS CUSTOMER-SUPPLIED SPECIFICATIONS; HOWEVER, IT REMAINS THE CUSTOMER'S RESPONSIBILITY TO VERIFY PROPER AND RELIABLE OPERATION IN THE ACTUAL APPLICATION. COMPONENT SUBSTITUTION AND PRINTED CIRCUIT LAYOUT MAY SIGNIFICANTLY AFFECT CIRCUIT PERFORMANCE OR RELIABILITY. CONTACT LINEAR TECHNOLOGY APPLICATIONS ENGINEERING FOR ASSISTANCE.		PCB DES.	CL
		APP ENG.	CUYLER L.
		SCALE = NONE	
THIS CIRCUIT IS PROPRIETARY TO LINEAR TECHNOLOGY AND SUPPLIED FOR USE WITH LINEAR TECHNOLOGY PARTS.			

CUSTOMER NOTICE

LINEAR TECHNOLOGY HAS MADE A BEST EFFORT TO DESIGN A CIRCUIT THAT MEETS CUSTOMER-SUPPLIED SPECIFICATIONS; HOWEVER, IT REMAINS THE CUSTOMER'S RESPONSIBILITY TO VERIFY PROPER AND RELIABLE OPERATION IN THE ACTUAL APPLICATION. COMPONENT SUBSTITUTION AND PRINTED CIRCUIT LAYOUT MAY SIGNIFICANTLY AFFECT CIRCUIT PERFORMANCE OR RELIABILITY. CONTACT LINEAR TECHNOLOGY APPLICATIONS ENGINEERING FOR ASSISTANCE.

THIS CIRCUIT IS PROPRIETARY TO LINEAR TECHNOLOGY AND SUPPLIED FOR USE WITH LINEAR TECHNOLOGY PARTS.

DEMO MANUAL DC1659A

DEMONSTRATION BOARD IMPORTANT NOTICE

Linear Technology Corporation (LTC) provides the enclosed product(s) under the following **AS IS** conditions:

This demonstration board (DEMO BOARD) kit being sold or provided by Linear Technology is intended for use for **ENGINEERING DEVELOPMENT OR EVALUATION PURPOSES ONLY** and is not provided by LTC for commercial use. As such, the DEMO BOARD herein may not be complete in terms of required design-, marketing-, and/or manufacturing-related protective considerations, including but not limited to product safety measures typically found in finished commercial goods. As a prototype, this product does not fall within the scope of the European Union directive on electromagnetic compatibility and therefore may or may not meet the technical requirements of the directive, or other regulations.

If this evaluation kit does not meet the specifications recited in the DEMO BOARD manual the kit may be returned within 30 days from the date of delivery for a full refund. **THE FOREGOING WARRANTY IS THE EXCLUSIVE WARRANTY MADE BY THE SELLER TO BUYER AND IS IN LIEU OF ALL OTHER WARRANTIES, EXPRESSED, IMPLIED, OR STATUTORY, INCLUDING ANY WARRANTY OF MERCHANTABILITY OR FITNESS FOR ANY PARTICULAR PURPOSE. EXCEPT TO THE EXTENT OF THIS INDEMNITY, NEITHER PARTY SHALL BE LIABLE TO THE OTHER FOR ANY INDIRECT, SPECIAL, INCIDENTAL, OR CONSEQUENTIAL DAMAGES.**

The user assumes all responsibility and liability for proper and safe handling of the goods. Further, the user releases LTC from all claims arising from the handling or use of the goods. Due to the open construction of the product, it is the user's responsibility to take any and all appropriate precautions with regard to electrostatic discharge. Also be aware that the products herein may not be regulatory compliant or agency certified (FCC, UL, CE, etc.).

No License is granted under any patent right or other intellectual property whatsoever. **LTC assumes no liability for applications assistance, customer product design, software performance, or infringement of patents or any other intellectual property rights of any kind.**

LTC currently services a variety of customers for products around the world, and therefore this transaction **is not exclusive**.

Please read the DEMO BOARD manual prior to handling the product. Persons handling this product must have electronics training and observe good laboratory practice standards. **Common sense is encouraged.**

This notice contains important safety information about temperatures and voltages. For further safety concerns, please contact a LTC application engineer.

Mailing Address:

Linear Technology
1630 McCarthy Blvd.
Milpitas, CA 95035

Copyright © 2004, Linear Technology Corporation