

## Linear Position Sensors

Type: **EVAW7**



### ■ Features

- A wide variety of operation strokes
- Long life and high resolution

### ■ Recommended Applications

- Car headlight angle detection sensor

### ■ Explanation Part Numbers

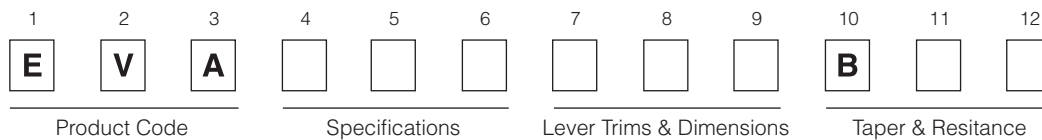

### ■ Specifications

		EVAW7	
Mechanical	Stroke	9.0 mm±0.5 mm	8.0 mm±0.5 mm
	Operating Force	2 N max.	1 N max.
Electrical	Linearity	±2 %	±1 %
	Total Resistance	10 kΩ±30 %	4.7 kΩ±30 %
	Voltage Rating	5 V DC max.	12 V DC max.
	Taper	B	
Endurance	Operating Life	10,000 cycles min.	10,000 cycles min.
Minimum Quantity/Packing Unit		300 pcs. (Tray Pack)	200 pcs. (Tray Pack)
Quantity/Carton		3,000 pcs.	2,000 pcs.

Design and specifications are each subject to change without notice. Ask factory for the current technical specifications before purchase and/or use.  
Should a safety concern arise regarding this product, please be sure to contact us immediately.

■ Dimensions in mm (not to scale)

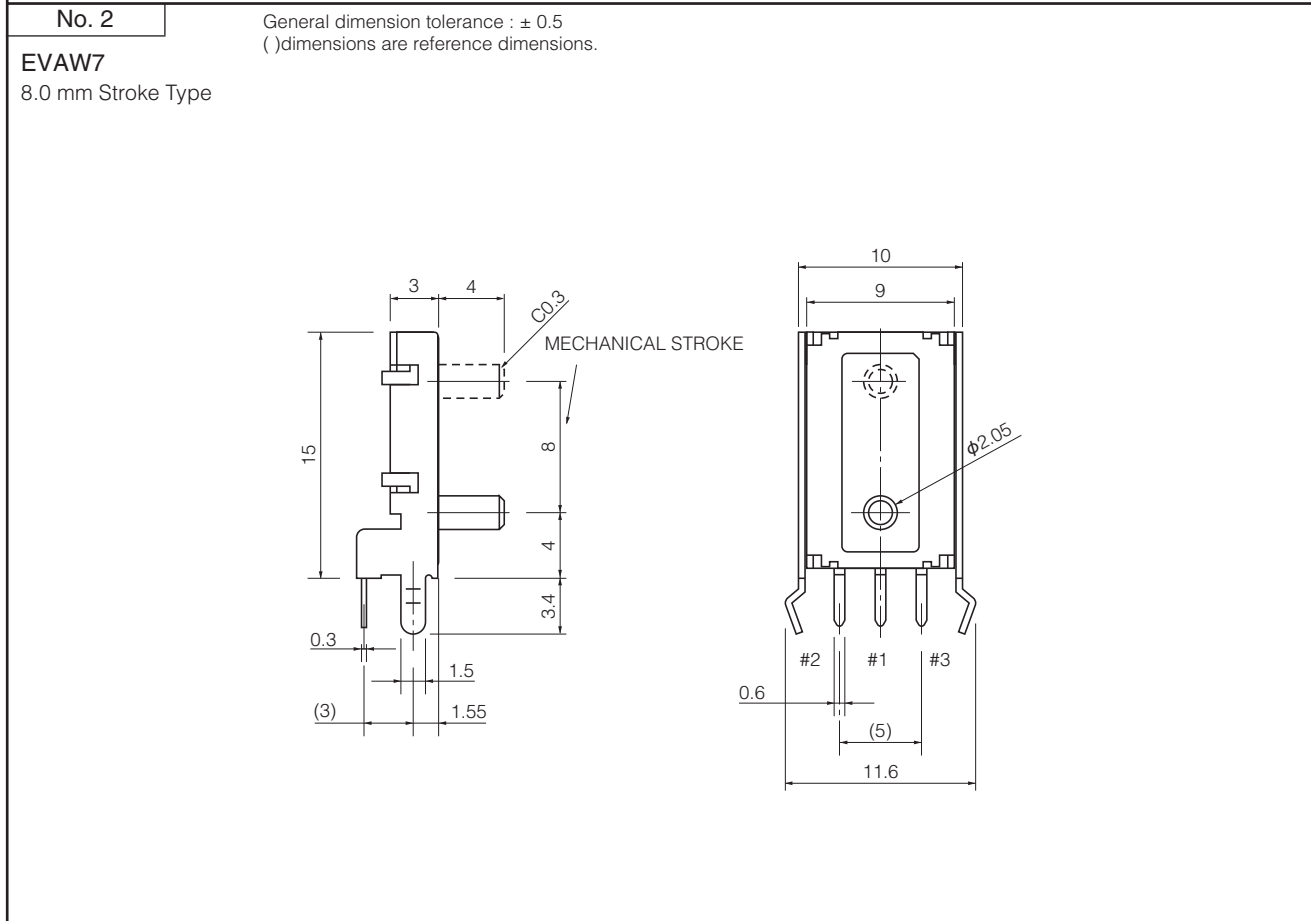
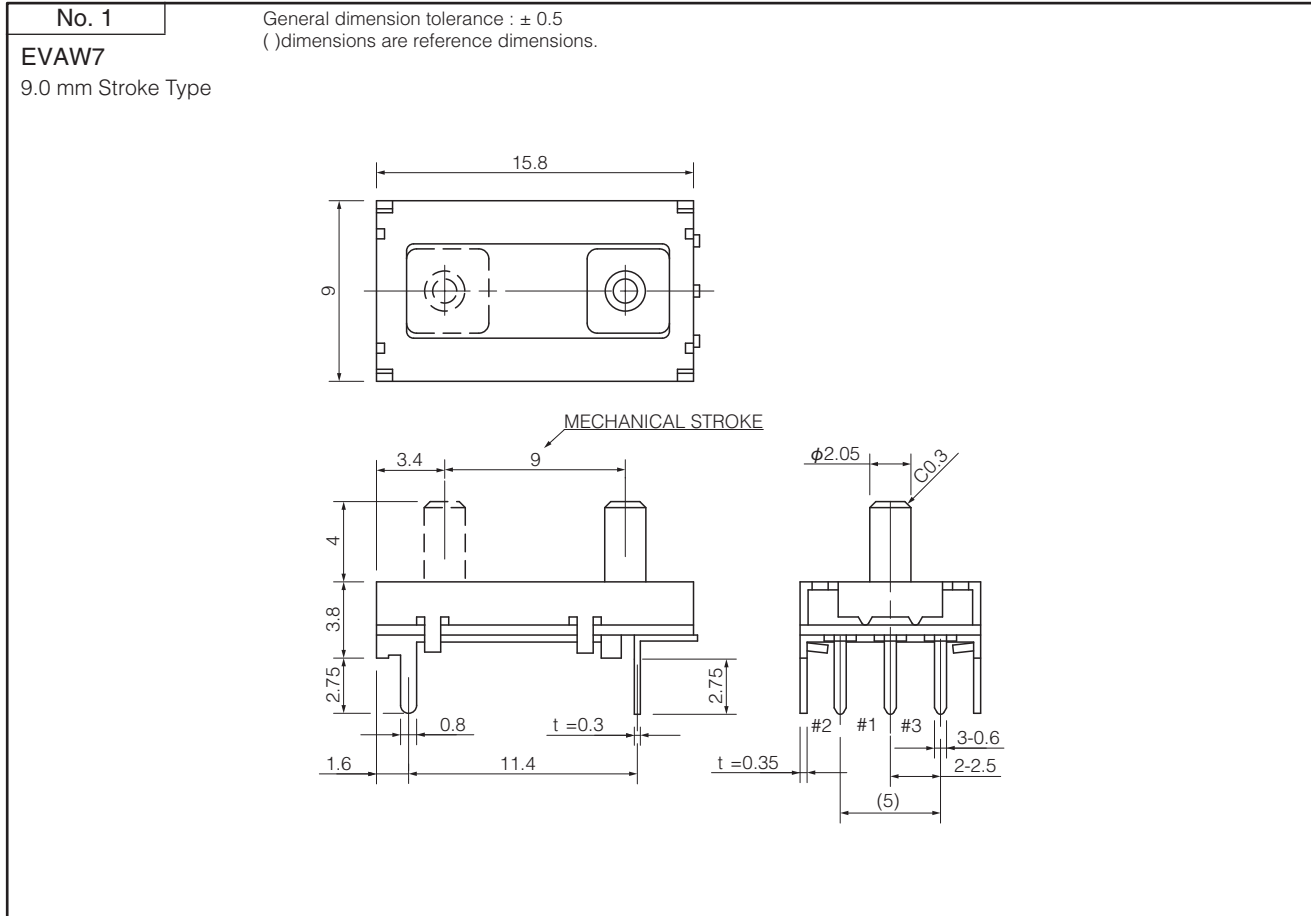

Design and specifications are each subject to change without notice. Ask factory for the current technical specifications before purchase and/or use.  
Should a safety concern arise regarding this product, please be sure to contact us immediately.

## ■ Circuit diagram

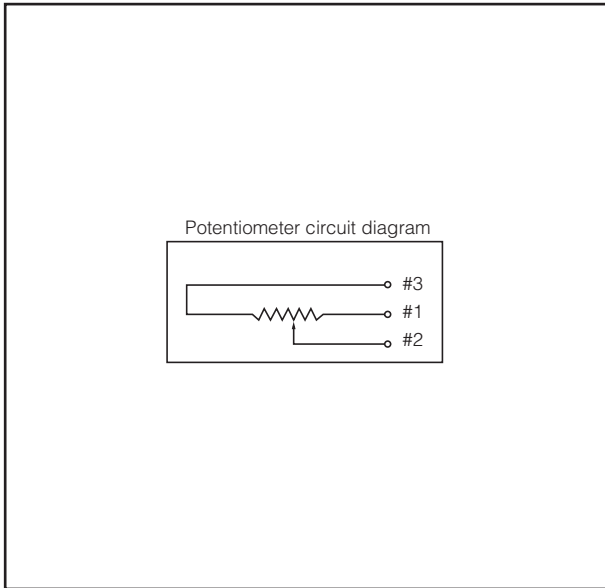

## ■ Test circuit diagram

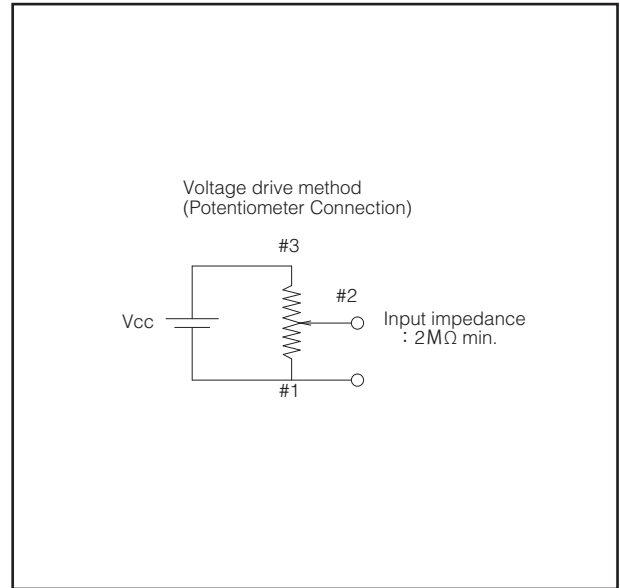

## ■ PWB mounting hole for reference

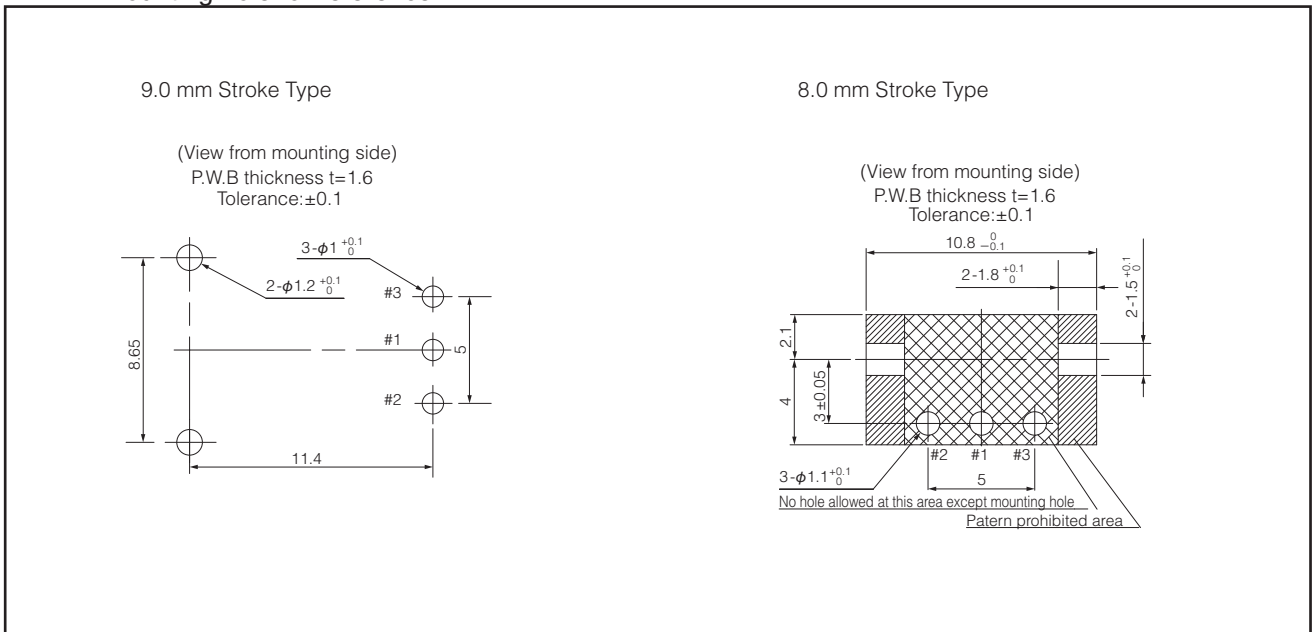

Design and specifications are each subject to change without notice. Ask factory for the current technical specifications before purchase and/or use.  
Should a safety concern arise regarding this product, please be sure to contact us immediately.