

Evaluating the **ADP5600** Interleaved Inverting Charge Pump with a Negative LDO Regulator

FEATURES

Input voltage range: 2.7 V to 16 V

LDO output voltage: user selectable via SEL1 and SEL2 pins

SEL1 = low, SEL2 = low: -0.505 V

SEL1 = high, SEL2 = low: -1.5 V

SEL1 = low, SEL2 = high: -2.5 V

SEL1 = high, SEL2 = high: -5.0 V

EVALUATION KIT CONTENTS

ADP5600CP-EVALZ evaluation board

ADDITIONAL EQUIPMENT NEEDED

DC power supply for V_{IN} and V_{EN}

Multimeters for voltage and current measurements

Electronic or resistive loads

GENERAL DESCRIPTION

The ADP5600CP-EVALZ evaluation board demonstrates the functionality of the ADP5600 interleaved inverting charge pump and a negative low dropout regulator (LDO).

The ADP5600CP-EVALZ evaluates simple device measurements such as line regulation, load regulation, and efficiency. Board features includes configuration of the LDO regulator output using SELx jumpers and synchronization of the operating frequency to the external clock.

A full description of the ADP5600 is available in the ADP5600 data sheet and should be consulted when using this evaluation board.

PHOTOGRAPH OF THE ADP5600CP-EVALZ EVALUATION BOARD

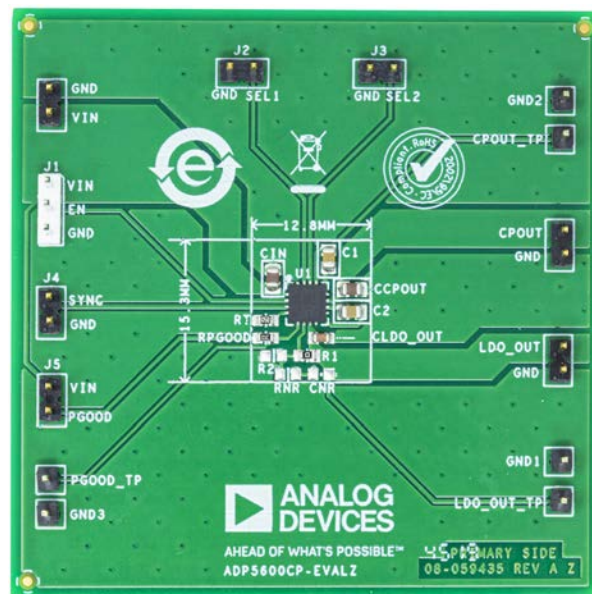

Figure 1.

TABLE OF CONTENTS

Features	1	Charge Pump Measurement Setup	4
Evaluation Kit Contents.....	1	LDO Measurement Setup.....	4
Additional Equipment Needed	1	Line Regulation.....	4
General Description	1	Load Regulation	4
Photograph of the ADP5600CP-EVALZ Evaluation Board	1	Efficiency	5
Revision History	2	Evaluation Board Schematics and Artwork	6
Evaluation Board Hardware.....	3	Ordering Information.....	7
Evaluation Board Configurations	3	Bill of Materials.....	7
Output Voltage Measurements	4		

REVISION HISTORY

8/2020—Revision 0: Initial Version

EVALUATION BOARD HARDWARE

EVALUATION BOARD CONFIGURATIONS

The ADP5600CP-EVALZ evaluation board is configured to provide a -2.5 V LDO output from a +2.7 V to +16 V input. To achieve this output voltage, the charge pump inverts the voltage at VIN and feeds it to the LDO. The LDO then regulates the inverted voltage to the user selected output voltage.

Table 1 lists the ADP5600CP-EVALZ functions and Table 2, the bill of materials, lists the components for the ADP5600 board. Figure 2 outlines the ADP5600CP-EVALZ features available to the user and its supporting components.

Table 1. Evaluation Board Function Descriptions

Jumper/Connector Mnemonic	Description
VIN	ADP5600 power input. In the default configuration, the power supply ranges from 2.7 V to 16 V.
EN	Enable input jumper. Connect EN to VIN to enable the ADP5600. Connect EN to GND to disable ADP5600.
SEL1	Output Voltage Selector 1. Insert Jumper J2 to short SEL1 to GND or remove Jumper J2 to float SEL1.
SEL2	Output Voltage Selector 2. Insert Jumper J3 to short SEL2 to GND or remove Jumper J3 to float SEL2.
SYNC	SYNC input pin. Connect an external clock to the SYNC header in J4 to synchronize the operating frequency.
CPOUT	Charge pump output. Connect the charge pump load to CPOUT.
CPOUT_TP	Charge pump output test point.
LDO_OUT	LDO output. Connect the LDO load to LDO_OUT.
LDO_OUT_TP	LDO output test point.
PGOOD_TP	Power-good test point.

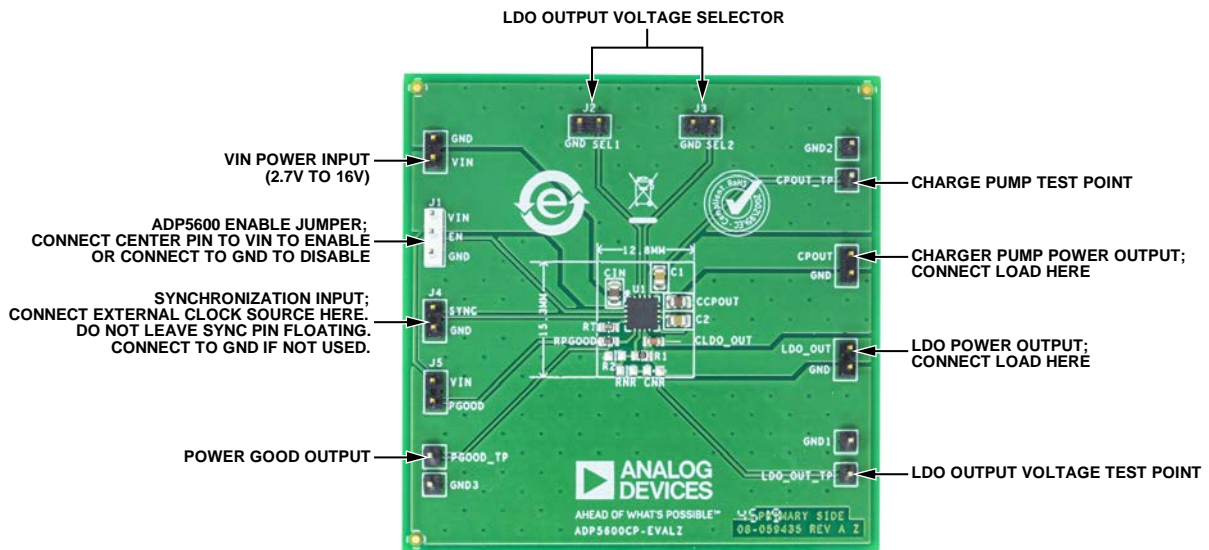

Figure 2. Outline of ADP5600 Evaluation Board Features

23960-002

OUTPUT VOLTAGE MEASUREMENTS

CHARGE PUMP MEASUREMENT SETUP

Figure 3 shows the recommended setup to evaluate the charge pump regulator of ADP5600CP-EVALZ. For accurate efficiency measurements, measure the input voltage between the VIN and GND test points and measure the output voltage between CPOUT_TP and GND2.

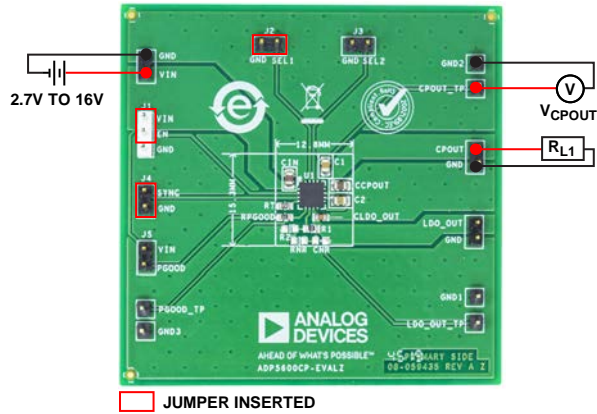

Figure 3. Charge Pump Measurement Setup

LDO MEASUREMENT SETUP

Figure 4 shows the recommended setup to evaluate the LDO regulator of ADP5600CP-EVALZ. The LDO output voltage measurements are measured between LDO_OUT_TP and GND1.

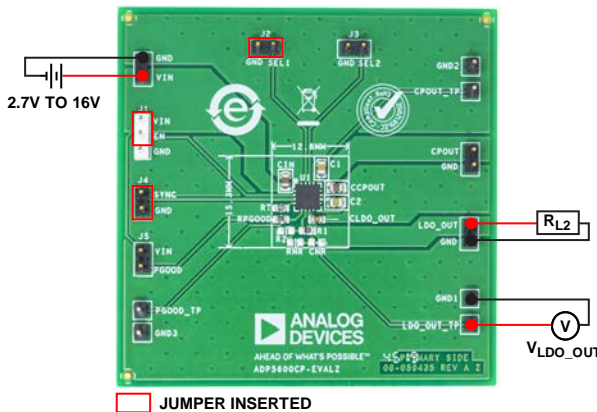

Figure 4. LDO Measurement Setup

LINE REGULATION

For line regulation measurements, monitor the regulator output while its input is varied. For good line regulation, the output must change as little as possible with varying input levels. It is possible to repeat this measurement under different load conditions. During line regulation tests, keep the power supply leads short and remove any additional input capacitors. Figure 5 shows the typical LDO line regulation performance of the ADP5600.

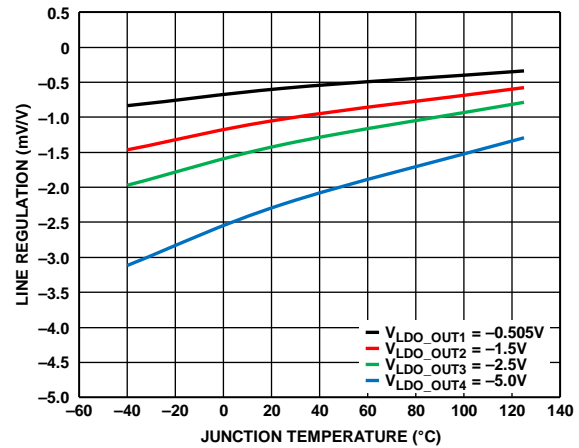

Figure 5. LDO Line Regulation

LOAD REGULATION

For load regulation measurements, monitor the regulator output while the load is varied. For good load regulation, the output must change as little as possible with varying loads. The input voltage must be held constant during this measurement. Figure 6 shows the typical LDO load regulation performance of the ADP5600. Keep power leads short during this test and compensate for voltage drops at the input or use a power supply with remote sense.

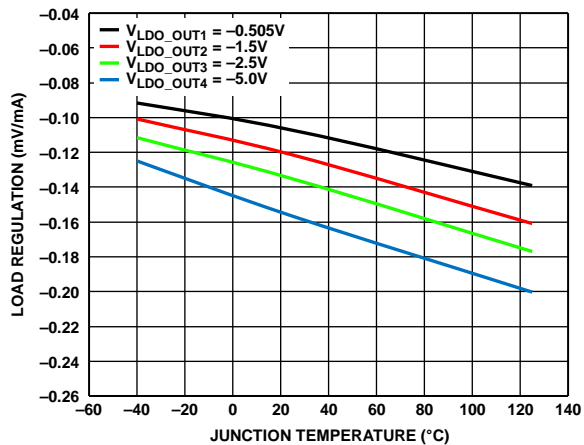

Figure 6. LDO Load Regulation

EFFICIENCY

For efficiency measurements, monitor the regulator input and output while the load is varied. The input voltage must be held constant during this measurement. Keep power leads short during this test and compensate for voltage drops at the input or use a power supply with remote sense. Connect ammeters in series with the input and output. Connect the voltmeters to their respective test points. If possible, particularly at low current, trigger the meters simultaneously and set the meters to average the readings for a period of a few hundred milliseconds or more. Figure 7 shows the typical efficiency curves for the charge pump.

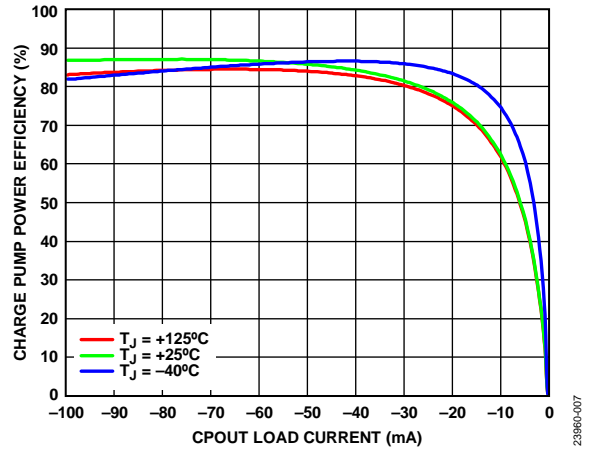

Figure 7. Charge Pump Power Efficiency

EVALUATION BOARD SCHEMATICS AND ARTWORK

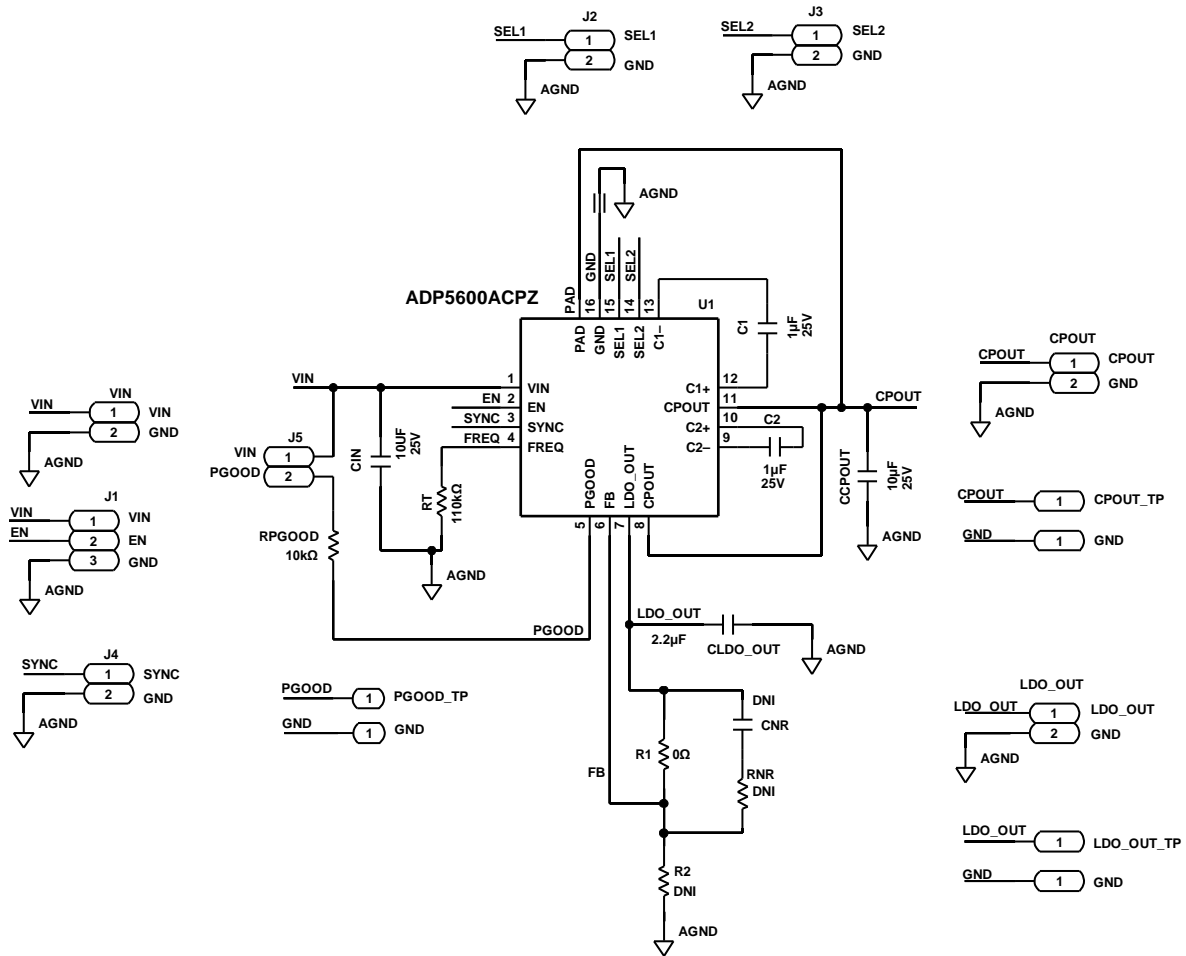

Figure 8. ADP5600CP-EVALZ Evaluation Board Schematic

23960-008

ORDERING INFORMATION

BILL OF MATERIALS

Table 2. Evaluation Board Components—ADP5600

Component	Description	Product Number	Manufacturer
U1	ADP5600, interleaved inverting charge pump with low dropout regulator	ADP5600ACPZ-R7	Analog Devices, Inc.
C1, C2	C1 and C2 Flying capacitors, 0805, 1 μ F, 10%, 25 V	08053C105K4T4A	AVX CORPORATION
CCPOUT	CPOUT output capacitor, 0805, 10 μ F, 10%, 25 V	GRM21BC71E106KE11L	MURATA
CIN	VIN input capacitor, 0805, 10 μ F, 10%, 25 V	GRM21BC71E106KE11L	MURATA
CLDO_OUT	LDO input and output capacitor, 0603, 2.2 μ F, 10%, 50 V	GRM188R61H225KE11J	MURATA
R1	Resistor, 0603, 0 Ω	MC0603WG00000T5E-TC	MULTICOMP
RPGOOD	PGOOD pull-up resistor, 0603, 10 k Ω	MC0603WGF1002T5E-TC	MULTICOMP
RT	RT frequency setting resistor, 0603, 110 k Ω	MCR03EZPFX1103	ROHM



ESD Caution

ESD (electrostatic discharge) sensitive device. Charged devices and circuit boards can discharge without detection. Although this product features patented or proprietary protection circuitry, damage may occur on devices subjected to high energy ESD. Therefore, proper ESD precautions should be taken to avoid performance degradation or loss of functionality.

Legal Terms and Conditions

By using the evaluation board discussed herein (together with any tools, components documentation or support materials, the "Evaluation Board"), you are agreeing to be bound by the terms and conditions set forth below ("Agreement") unless you have purchased the Evaluation Board, in which case the Analog Devices Standard Terms and Conditions of Sale shall govern. Do not use the Evaluation Board until you have read and agreed to the Agreement. Your use of the Evaluation Board shall signify your acceptance of the Agreement. This Agreement is made by and between you ("Customer") and Analog Devices, Inc. ("ADI"), with its principal place of business at One Technology Way, Norwood, MA 02062, USA. Subject to the terms and conditions of the Agreement, ADI hereby grants to Customer a free, limited, personal, temporary, non-exclusive, non-sublicensable, non-transferable license to use the Evaluation Board FOR EVALUATION PURPOSES ONLY. Customer understands and agrees that the Evaluation Board is provided for the sole and exclusive purpose referenced above, and agrees not to use the Evaluation Board for any other purpose. Furthermore, the license granted is expressly made subject to the following additional limitations: Customer shall not (i) rent, lease, display, sell, transfer, assign, sublicense, or distribute the Evaluation Board; and (ii) permit any Third Party to access the Evaluation Board. As used herein, the term "Third Party" includes any entity other than ADI, Customer, their employees, affiliates and in-house consultants. The Evaluation Board is NOT sold to Customer; all rights not expressly granted herein, including ownership of the Evaluation Board, are reserved by ADI. CONFIDENTIALITY. This Agreement and the Evaluation Board shall all be considered the confidential and proprietary information of ADI. Customer may not disclose or transfer any portion of the Evaluation Board to any other party for any reason. Upon discontinuation of use of the Evaluation Board or termination of this Agreement, Customer agrees to promptly return the Evaluation Board to ADI. ADDITIONAL RESTRICTIONS. Customer may not disassemble, decompile or reverse engineer chips on the Evaluation Board. Customer shall inform ADI of any occurred damages or any modifications or alterations it makes to the Evaluation Board, including but not limited to soldering or any other activity that affects the material content of the Evaluation Board. Modifications to the Evaluation Board must comply with applicable law, including but not limited to the RoHS Directive. TERMINATION. ADI may terminate this Agreement at any time upon giving written notice to Customer. Customer agrees to return to ADI the Evaluation Board at that time. LIMITATION OF LIABILITY. THE EVALUATION BOARD PROVIDED HEREUNDER IS PROVIDED "AS IS" AND ADI MAKES NO WARRANTIES OR REPRESENTATIONS OF ANY KIND WITH RESPECT TO IT. ADI SPECIFICALLY DISCLAIMS ANY REPRESENTATIONS, ENDORSEMENTS, GUARANTEES, OR WARRANTIES, EXPRESS OR IMPLIED, RELATED TO THE EVALUATION BOARD INCLUDING, BUT NOT LIMITED TO, THE IMPLIED WARRANTY OF MERCHANTABILITY, TITLE, FITNESS FOR A PARTICULAR PURPOSE OR NON-INFRINGEMENT OF INTELLECTUAL PROPERTY RIGHTS. IN NO EVENT WILL ADI AND ITS LICENSORS BE LIABLE FOR ANY INCIDENTAL, SPECIAL, INDIRECT, OR CONSEQUENTIAL DAMAGES RESULTING FROM CUSTOMER'S POSSESSION OR USE OF THE EVALUATION BOARD, INCLUDING BUT NOT LIMITED TO LOST PROFITS, DELAY COSTS, LABOR COSTS OR LOSS OF GOODWILL. ADI'S TOTAL LIABILITY FROM ANY AND ALL CAUSES SHALL BE LIMITED TO THE AMOUNT OF ONE HUNDRED US DOLLARS (\$100.00). EXPORT. Customer agrees that it will not directly or indirectly export the Evaluation Board to another country, and that it will comply with all applicable United States federal laws and regulations relating to exports. GOVERNING LAW. This Agreement shall be governed by and construed in accordance with the substantive laws of the Commonwealth of Massachusetts (excluding conflict of law rules). Any legal action regarding this Agreement will be heard in the state or federal courts having jurisdiction in Suffolk County, Massachusetts, and Customer hereby submits to the personal jurisdiction and venue of such courts. The United Nations Convention on Contracts for the International Sale of Goods shall not apply to this Agreement and is expressly disclaimed.

©2020 Analog Devices, Inc. All rights reserved. Trademarks and registered trademarks are the property of their respective owners.
UG23960-8/20(0)



www.analog.com