

LTC4370 Two-Supply Diode-OR Current Balancing Controller

DESCRIPTION

Demonstration circuit DC1741B features the [LTC®4370](#), a two supply diode-OR current sharing controller in a typical 2.9V to 18V, 16A sharing application.

The maximum MOSFET voltage drop $V_{FR} = V_{IN} - V_{OUT}$ is set with an external resistor, up to 600mV. A fast gate turn-on reduces the load voltage droop during supply switchover. If the input supply fails or is shorted, a fast turn-off minimizes the transient reverse current.

Disabling the load sharing function turns the LTC4370 into a dual ideal diode controller.

Two enable input pins, $\overline{EN1}$ and $\overline{EN2}$, allow enabling and disabling each rail's MOSFET individually while the MOSFETs' inherent diodes create diode-OR connection

when the MOSFETs are disabled. The LTC4370 provides a rich set of features to support shared current diode-ORed applications including:

- Load Sharing Between Two Supplies
- Elimination of the Need for Active Control of Input Supplies
- Elimination of "Share Bus"
- Reverse Current Blocking
- Elimination of Shoot-Through Current During Start-Up or Faults

[Design files for this circuit board are available.](#)

All registered trademarks and trademarks are the property of their respective owners.

PERFORMANCE SUMMARY Specifications are at $T_A = 25^\circ\text{C}$

SYMBOL	PARAMETER	CONDITIONS	MIN	TYP	MAX	UNITS
V_{IN}	V_{IN1} and V_{IN2} Input Voltage Operating Range	With External V_{CC} Supply	2.9 0		18 V_{CC}	V
$V_{CC(EXT)}$	V_{CC} External Supply Operating Range	$V_{IN1}, V_{IN2} \leq V_{CC}$	2.9		6.0	V
$V_{CC(REG)}$	V_{CC} Regulated Voltage		4.5	5	5.5	V
$V_{EA(OS)}$	Error Amplifier Input Offset			0	± 2	mV
$g_{m(EA)}$	Error Amplifier Gain			150		μS
V_{FR}	Forward Regulation Voltage ($V_{IN} - V_{OUT}$)	$V_{IN} = 1.2\text{V}, V_{CC} = 5\text{V}$ $V_{IN} = 12\text{V}$	2 2	12 25	25 50	mV mV
ΔV_{GATE}	MOSFET Gate Drive ($GATE - V_{IN}$)	$V_{FWD} = 0.2\text{V}; I = 0, -1\mu\text{A}; \text{Highest } V_{IN} = 12\text{V}$ $V_{FWD} = 0.2\text{V}; I = 0, -1\mu\text{A}; \text{Highest } V_{IN} = 2.9\text{V}$	10 4.5	12 7	14 9	V V
I_{GATE}	GATE1, GATE2 Fast Pull-Up Current GATE1, GATE2 Fast Down-Up Current GATE1, GATE2 Off Pull-Down Current	$V_{FWD} = 0.4\text{V}, \Delta V_{GATE} = 0\text{V}, CPO = 17\text{V}$ $V_{FWD} = -2\text{V}, \Delta V_{GATE} = 5\text{V},$ Corresponding $\overline{EN} = 1\text{V}, \Delta V_{GATE} = 2.5\text{V}$	-0.9 0.9 65	-1.4 1.4 110	-1.9 1.9 160	A A μA
$V_{EN(TH)}$	$\overline{EN1}, \overline{EN2}$ Threshold Voltage	\overline{EN} Falling	580	600	620	mV
$\Delta V_{GATE(ON)}$	MOSFET On-Detect Threshold ($GATE - V_{IN}$)	FETON Transitions High	0.28	0.7	1.1	V
I_{OUT}	Maximum Continuous Load Current	Sharing active, limited by SUM90N04-3m3P-E3 Dissipation			16.6	A

OPERATING PRINCIPLES

The LTC4370 controls N-channel MOSFETs, M1 and M2, to share the load between two input rails. The error amplifier compares OUT1 and OUT2, and controls servo amplifiers which regulate the MOSFET forward voltage drop to V_{FR} . Combined action of the error amplifier and servo amplifiers forces OUT1 and OUT2 to be equal and as a result the rail currents are equal. The board RANGE resistor $R3 = 30.1k$ defines the maximum regulation voltage range as 265mV to 375mV.

The board is assembled with SUM90N04-3m3P-E3 N-channel MOSFETs, which in a single channel application has current capability up to 20A. In the load share mode, the installed components guarantee continuous proper load sharing up to 16.6A total load. For a short test time of 3 to 5 seconds, it is possible to double this load.

Two LEDs, OFF1 and OFF2, indicate the MOSFETs' status. Each LED lights up when the gate voltage is less than 0.7V above V_{IN} .

Pay special attention to the power supply features used with the LTC4370.

This controller may not work properly with supplies utilizing synchronized rectification in the output stage unless the internal circuit of the supply has the ability to limit negative current or to block it completely. Exercise caution when using the controller with this type of supply unless it is determined that it contains the required circuitry.

QUICK START PROCEDURE

Demonstration circuit DC1741B is easy to set up to evaluate the performance of the LTC4370. Refer to Figure 1 for proper measurement equipment setup for load share observation.

1. Turn both supplies on. Adjust two 5V supplies' outputs to a 215mV difference, which equals the minimum $\Delta V_{IN(MIN)}$ load share breakpoint (265mV–50mV). Load the LTC4370 output with minimal current so that both supplies contribute current to the common load. Increase load up to 35A and observe the LTC4370 operation mode with accurate load sharing. It is easy to estimate load share accuracy by measuring a voltage between two sense resistors. Since the MOSFETs will be dissipating excessive power, limit this measurement to 3 to 5 seconds when at the 35A level.

2. Reduce the load current to a total of 7.5A. Adjust the two 5V supplies' outputs to a voltage difference of 373 mV, which equals the maximum $\Delta V_{IN(MAX)}$ load share breakpoint (375mV–2mV). As the difference between power supplies output is greater than the maximum voltage regulation, the LTC4370 channel with the higher voltage will provide most of the current. Increase the voltage until all of the current is provided by the higher voltage supply. This is the point at which the MOSFET of the higher voltage channel MOSFET is fully enhanced while the MOSFET of the lower channel voltage is completely cut off. Observe that the LED of the lower supply is illuminated.

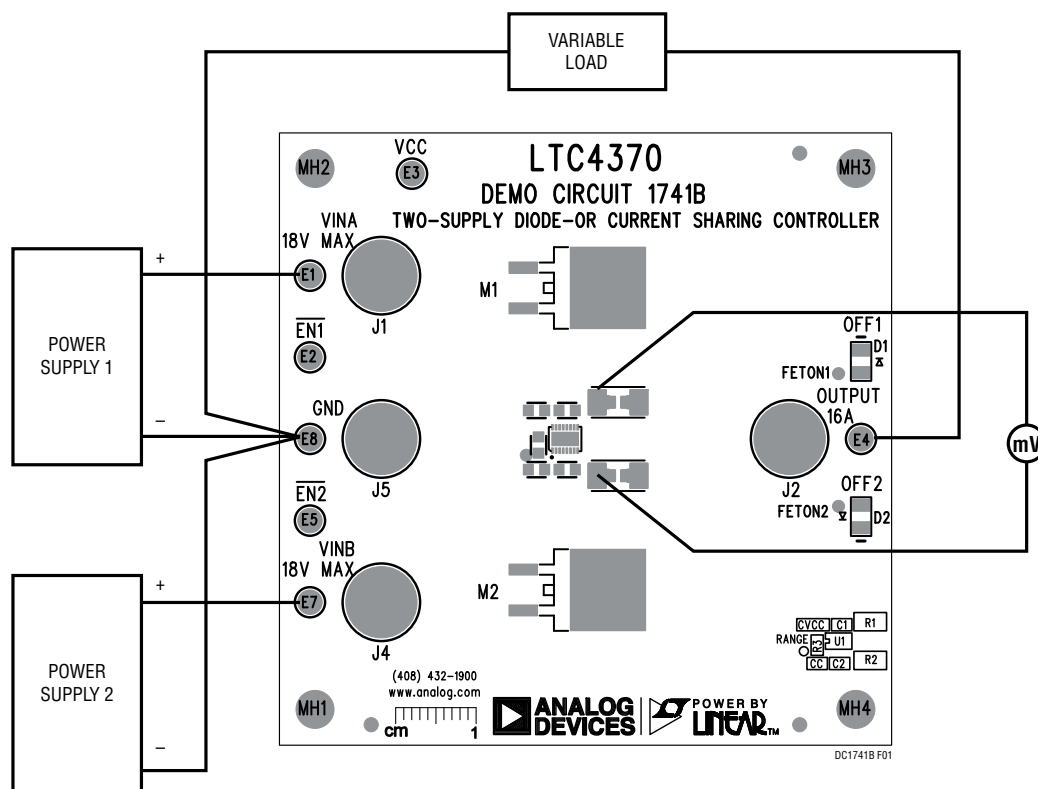

Figure 1. Load Share Performance Measurement

DEMO MANUAL DC1741B

PARTS LIST

ITEM	QTY	REFERENCE	PART DESCRIPTION	MANUFACTURER/PART NUMBER
Required Circuit Components				
1	1	CC	Cap., X7R, 0.18 μ F, 25V, 10%, 0805	AVX, 08053C184KAT2A
2	1	CV _{CC}	Cap., X7R, 0.1 μ F, 50V, 10%, 0805	AVX, 08055C104KAT2A
3	2	C1, C2	Cap., X7R, 0.039 μ F, 50V, 10%, 0805	AVX, 08055C393KAT2A
4	2	D1, D2	LED, RED	Panasonic, LN1251C-TR
5	2	D3, D4	Current Limiting Diode, 3.2V, SOD-80	Central Semi. Corp. CMJ3500
6	7	E1, E2, E3, E4, E5, E7, E8	Turret, Testpoint 0.063"	Mill-Max, 2308-2-00-80-00-00-07-0
7	4	J1, J2, J4, J5	Connector, Banana Jack	Keystone, 575-4
8	2	M1, M2	MOSFET N-Channel, 30V, D2PAK	Vishay, SUM90N04-3m3P-E3
9	2	R1, R2	Res., WSL 0.002 1W, 1%, 2512	Vishay, WSL25122L000FEA
10	1	R3	Res., Chip 30.1k, 0.1W 1%, 0805	Vishay, CRCW080530K1FKEA
11	2	R4, R6	Res., Chip 10k, 0.1W, 5%, 0805	Vishay, CRCW080510K0JNEA
12	0	R5, R7	Res., 0805	OPT
13	1	U1	I.C., Diode-OR Load Share Cont., DFN16DE-4 \times 3	Linear Technology Corp., LTC4370CDE

SCHEMATIC DIAGRAM

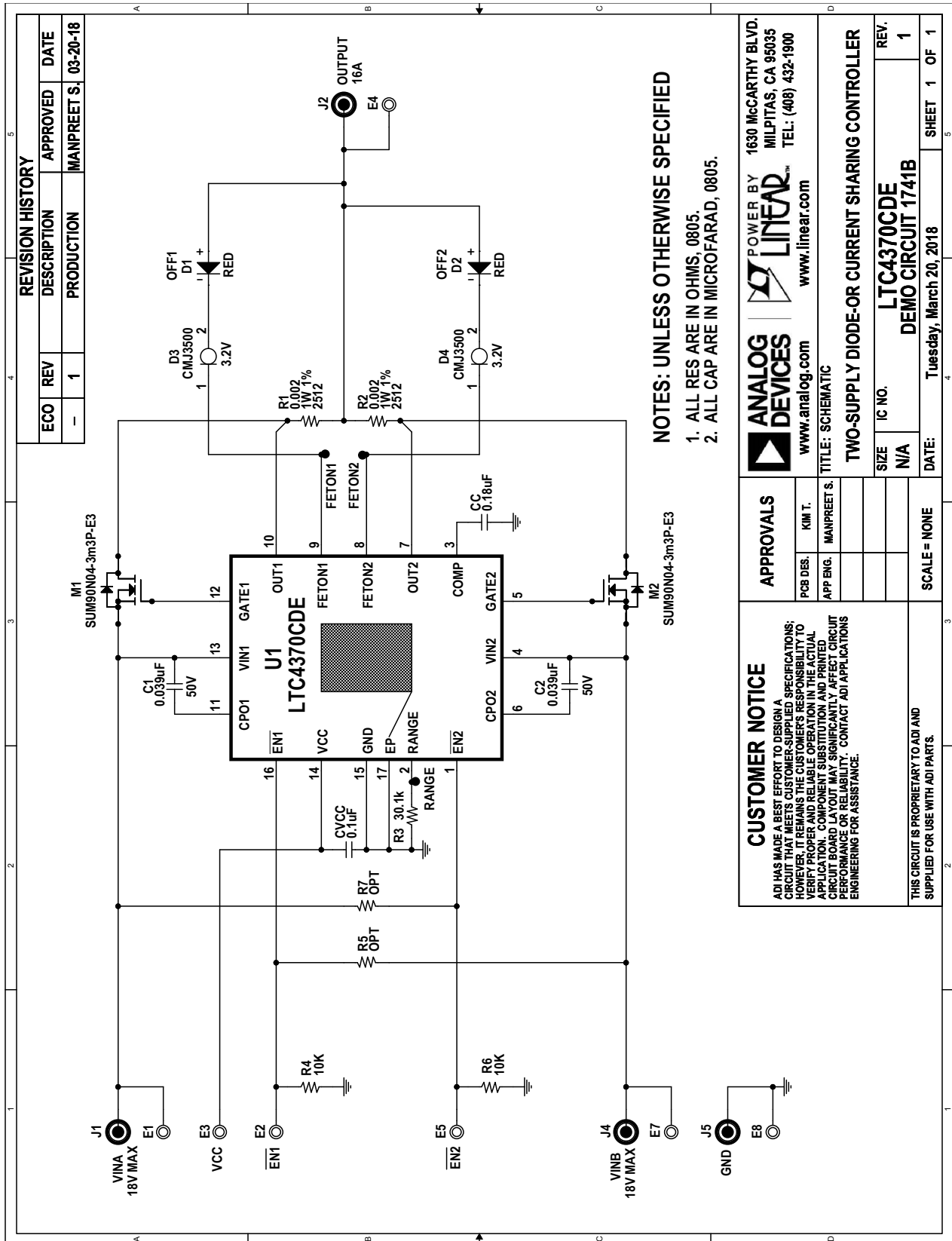

REVISION HISTORY				
ECO	REV	DESCRIPTION	APPROVED	DATE
-	1	PRODUCTION	MANPREET S.	03-20-18

NOTES: UNLESS OTHERWISE SPECIFIED

1. ALL RES ARE IN OHMS, 0805.
2. ALL CAP ARE IN MICROFARAD, 0805.

	POWER BY 		1630 MCCARTHY BLVD. MILPITAS, CA 95035 TEL: (408) 432-1900 www.linear.com	
	TITLE: SCHEMATIC			
APPROVALS		TWO-SUPPLY DIODE-OR CURRENT SHARING CONTROLLER		
PCB DES:	KIM T.	SIZE	IC NO.	REV.
APP ENG:	MANPREET S.	N/A	LTC4370CDE	1
		DATE:	DEMO CIRCUIT 1741B	
		SCALE =	NONE	
		THIS CIRCUIT IS PROPRIETARY TO ADI AND SUPPLIED FOR USE WITH ADI PARTS.		
		DATE:	Tuesday, March 20, 2018	SHEET 1 OF 1

CUSTOMER NOTICE

ADI HAS MADE A BEST EFFORT TO DESIGN A CIRCUIT THAT MEETS CUSTOMER-SUPPLIED SPECIFICATIONS; HOWEVER, IT REMAINS THE CUSTOMER'S RESPONSIBILITY TO VERIFY PROPER AND RELIABLE OPERATION IN THE ACTUAL APPLICATION. COMPONENT SUBSTITUTION AND PRINTED CIRCUIT BOARD LAYOUT MAY SIGNIFICANTLY AFFECT CIRCUIT PERFORMANCE OR RELIABILITY. CONTACT ADI APPLICATIONS ENGINEERING FOR ASSISTANCE.



ESD Caution

ESD (electrostatic discharge) sensitive device. Charged devices and circuit boards can discharge without detection. Although this product features patented or proprietary protection circuitry, damage may occur on devices subjected to high energy ESD. Therefore, proper ESD precautions should be taken to avoid performance degradation or loss of functionality.

Legal Terms and Conditions

By using the evaluation board discussed herein (together with any tools, components documentation or support materials, the "Evaluation Board"), you are agreeing to be bound by the terms and conditions set forth below ("Agreement") unless you have purchased the Evaluation Board, in which case the Analog Devices Standard Terms and Conditions of Sale shall govern. Do not use the Evaluation Board until you have read and agreed to the Agreement. Your use of the Evaluation Board shall signify your acceptance of the Agreement. This Agreement is made by and between you ("Customer") and Analog Devices, Inc. ("ADI"), with its principal place of business at One Technology Way, Norwood, MA 02062, USA. Subject to the terms and conditions of the Agreement, ADI hereby grants to Customer a free, limited, personal, temporary, non-exclusive, non-sublicensable, non-transferable license to use the Evaluation Board FOR EVALUATION PURPOSES ONLY. Customer understands and agrees that the Evaluation Board is provided for the sole and exclusive purpose referenced above, and agrees not to use the Evaluation Board for any other purpose. Furthermore, the license granted is expressly made subject to the following additional limitations: Customer shall not (i) rent, lease, display, sell, transfer, assign, sublicense, or distribute the Evaluation Board; and (ii) permit any Third Party to access the Evaluation Board. As used herein, the term "Third Party" includes any entity other than ADI, Customer, their employees, affiliates and in-house consultants. The Evaluation Board is NOT sold to Customer; all rights not expressly granted herein, including ownership of the Evaluation Board, are reserved by ADI. CONFIDENTIALITY. This Agreement and the Evaluation Board shall all be considered the confidential and proprietary information of ADI. Customer may not disclose or transfer any portion of the Evaluation Board to any other party for any reason. Upon discontinuation of use of the Evaluation Board or termination of this Agreement, Customer agrees to promptly return the Evaluation Board to ADI. ADDITIONAL RESTRICTIONS. Customer may not disassemble, decompile or reverse engineer chips on the Evaluation Board. Customer shall inform ADI of any occurred damages or any modifications or alterations it makes to the Evaluation Board, including but not limited to soldering or any other activity that affects the material content of the Evaluation Board. Modifications to the Evaluation Board must comply with applicable law, including but not limited to the RoHS Directive. TERMINATION. ADI may terminate this Agreement at any time upon giving written notice to Customer. Customer agrees to return to ADI the Evaluation Board at that time. LIMITATION OF LIABILITY. THE EVALUATION BOARD PROVIDED HEREUNDER IS PROVIDED "AS IS" AND ADI MAKES NO WARRANTIES OR REPRESENTATIONS OF ANY KIND WITH RESPECT TO IT. ADI SPECIFICALLY DISCLAIMS ANY REPRESENTATIONS, ENDORSEMENTS, GUARANTEES, OR WARRANTIES, EXPRESS OR IMPLIED, RELATED TO THE EVALUATION BOARD INCLUDING, BUT NOT LIMITED TO, THE IMPLIED WARRANTY OF MERCHANTABILITY, TITLE, FITNESS FOR A PARTICULAR PURPOSE OR NON-INFRINGEMENT OF INTELLECTUAL PROPERTY RIGHTS. IN NO EVENT WILL ADI AND ITS LICENSORS BE LIABLE FOR ANY INCIDENTAL, SPECIAL, INDIRECT, OR CONSEQUENTIAL DAMAGES RESULTING FROM CUSTOMER'S POSSESSION OR USE OF THE EVALUATION BOARD, INCLUDING BUT NOT LIMITED TO LOST PROFITS, DELAY COSTS, LABOR COSTS OR LOSS OF GOODWILL. ADI'S TOTAL LIABILITY FROM ANY AND ALL CAUSES SHALL BE LIMITED TO THE AMOUNT OF ONE HUNDRED US DOLLARS (\$100.00). EXPORT. Customer agrees that it will not directly or indirectly export the Evaluation Board to another country, and that it will comply with all applicable United States federal laws and regulations relating to exports. GOVERNING LAW. This Agreement shall be governed by and construed in accordance with the substantive laws of the Commonwealth of Massachusetts (excluding conflict of law rules). Any legal action regarding this Agreement will be heard in the state or federal courts having jurisdiction in Suffolk County, Massachusetts, and Customer hereby submits to the personal jurisdiction and venue of such courts. The United Nations Convention on Contracts for the International Sale of Goods shall not apply to this Agreement and is expressly disclaimed.