

# Micropower DC/DC Converter Adjustable and Fixed 5V, 12V

## FEATURES

- Operates at Supply Voltages From 2.0V to 30V
- Consumes Only 110 $\mu$ A Supply Current
- Works in Step-Up or Step-Down Mode
- Only Three External Components Required
- Low Battery Detector Comparator On-Chip
- User-Adjustable Current Limit
- Internal 1A Power Switch
- Fixed or Adjustable Output Voltage Versions
- Space Saving 8-Pin MiniDIP or SO8 Package

## APPLICATIONS

- Flash Memory Vpp Generators
- 3V to 5V, 5V to 12V Converters
- 9V to 5V, 12V to 5V Converters
- LCD Bias Generators
- Peripherals and Add-On Cards
- Battery Backup Supplies
- Laptop and Palmtop Computers
- Cellular Telephones
- Portable Instruments

## DESCRIPTION

The LT1173 is a versatile micropower DC-DC converter. The device requires only three external components to deliver a fixed output of 5V or 12V. Supply voltage ranges from 2.0V to 12V in step-up mode and to 30V in step-down mode. The LT1173 functions equally well in step-up, step-down or inverting applications.

The LT1173 consumes just 110 $\mu$ A supply current at standby, making it ideal for applications where low quiescent current is important. The device can deliver 5V at 80mA from a 3V input in step-up mode or 5V at 200mA from a 12V input in step-down mode.

Switch current limit can be programmed with a single resistor. An auxiliary gain block can be configured as a low battery detector, linear post regulator, under voltage lock-out circuit or error amplifier.

For input sources of less than 2V, use the LT1073.

 and LTC are registered trademarks and LT is a trademark of Linear Technology Corporation.

## TYPICAL APPLICATIONS

Logic Controlled Flash Memory VPP Generator

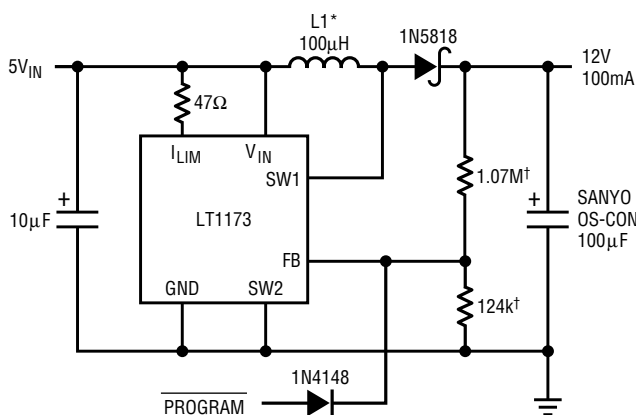

\*L1 = GOWANDA GA20-103K  
 COILTRONICS CTX100-4  
 NO OVERSHOOT

EFFICIENCY = 81%  
 † = 1% METAL FILM

LT1173 • TA01

VPP Output

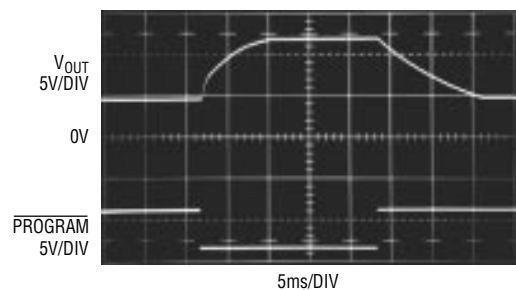

1173 TA02

**ABSOLUTE MAXIMUM RATINGS**

Supply Voltage ( $V_{IN}$ ) .....	36V
SW1 Pin Voltage ( $V_{SW1}$ ) .....	50V
SW2 Pin Voltage ( $V_{SW2}$ ) .....	-0.5V to $V_{IN}$
Feedback Pin Voltage (LT1173) .....	5V
Sense Pin Voltage (LT1173, -5, -12) .....	36V
Maximum Power Dissipation .....	500mW
Maximum Switch Current .....	1.5A
Operating Temperature Range .....	0°C to 70°C
Storage Temperature Range .....	-65°C to 150°C
Lead Temperature, (Soldering, 10 sec.) .....	300°C

Consult factory for Industrial and Military grade parts

**PACKAGE/ORDER INFORMATION**

	ORDER PART NUMBER
	LT1173CN8 LT1173CN8-5 LT1173CN8-12
	LT1173CS8 LT1173CS8-5 LT1173CS8-12
	S8 PART MARKING
	1173 11735 117312

**ELECTRICAL CHARACTERISTICS**  $T_A = 25^\circ\text{C}$ ,  $V_{IN} = 3\text{V}$ , unless otherwise noted.

SYMBOL	PARAMETER	CONDITIONS	MIN	TYP	MAX	UNITS	
$I_Q$	Quiescent Current	Switch Off	●	110	150	$\mu\text{A}$	
$I_Q$	Quiescent Current, Boost Mode Configuration	No Load	LT1173-5	135		$\mu\text{A}$	
			LT1173-12	250		$\mu\text{A}$	
$V_{IN}$	Input Voltage	Step-Up Mode	●	2.0	12.6	V	
		Step-Down Mode	●		30	V	
	Comparator Trip Point Voltage	LT1173 (Note 1)	●	1.20	1.245	1.30	V
$V_{OUT}$	Output Sense Voltage	LT1173-5 (Note 2)	●	4.75	5.00	5.25	V
		LT1173-12 (Note 2)	●	11.4	12.0	12.6	V
	Comparator Hysteresis	LT1173	●	5	10	mV	
	Output Hysteresis	LT1173-5	●	20	40	mV	
		LT1173-12	●	50	100	mV	
$f_{OSC}$	Oscillator Frequency		●	18	23	30	kHz
		Duty Cycle	Full Load	●	43	51	59
$t_{ON}$	Switch ON Time	$I_{LIM}$ tied to $V_{IN}$	●	17	22	32	$\mu\text{s}$
		Feedback Pin Bias Current	LT1173, $V_{FB} = 0\text{V}$	●	10	50	nA
	Set Pin Bias Current	$V_{SET} = V_{REF}$	●	20	100	nA	
$V_{OL}$	Gain Block Output Low	$I_{SINK} = 100\mu\text{A}$ , $V_{SET} = 1.00\text{V}$	●	0.15	0.4	V	
	Reference Line Regulation	$2.0\text{V} \leq V_{IN} \leq 5\text{V}$	●	0.2	0.4	%/V	
		$5\text{V} \leq V_{IN} \leq 30\text{V}$	●	0.02	0.075	%/V	
$V_{SAT}$	SW <sub>SAT</sub> Voltage, Step-Up Mode	$V_{IN} = 3.0\text{V}$ , $I_{SW} = 650\text{mA}$	●	0.5	0.65	V	
		$V_{IN} = 5.0\text{V}$ , $I_{SW} = 1\text{A}$	●	0.8	1.0	V	
			●		1.4	V	

# ELECTRICAL CHARACTERISTICS $T_A = 25^\circ\text{C}$ , $V_{IN} = 3\text{V}$ , unless otherwise noted.

SYMBOL	PARAMETER	CONDITIONS	MIN	TYP	MAX	UNITS
$V_{SAT}$	SW <sub>SAT</sub> Voltage, Step-Down Mode	$V_{IN} = 12\text{V}$ , $I_{SW} = 650\text{mA}$		1.1	1.5	V
			●		1.7	V
$A_V$	Gain Block Gain	$R_L = 100\text{k}\Omega$ (Note 3)	●	400	1000	V/V
	Current Limit	$220\Omega$ to $I_{LIM}$ to $V_{IN}$		400		mA
	Current Limit Temperature Coeff.		●	-0.3		%/ $^\circ\text{C}$
	Switch OFF Leakage Current	Measured at SW1 Pin		1	10	$\mu\text{A}$
$V_{SW2}$	Maximum Excursion Below GND	$I_{SW1} \leq 10\mu\text{A}$ , Switch Off		-400	-350	mV

The ● denotes the specifications which apply over the full operating temperature range.

**Note 1:** This specification guarantees that both the high and low trip points of the comparator fall within the 1.20V to 1.30V range.

**Note 2:** The output voltage waveform will exhibit a sawtooth shape due to the comparator hysteresis. The output voltage on the fixed output versions will always be within the specified range.

**Note 3:** 100k $\Omega$  resistor connected between a 5V source and the AO pin.

## TYPICAL PERFORMANCE CHARACTERISTICS

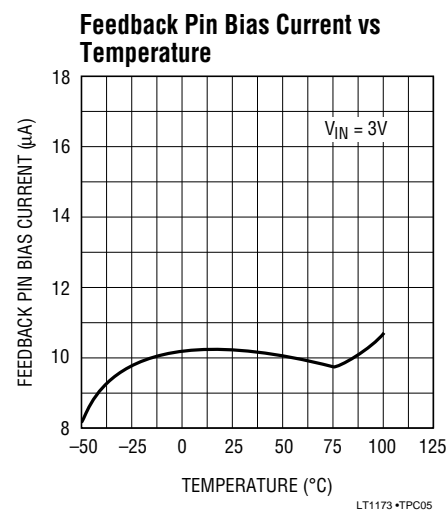
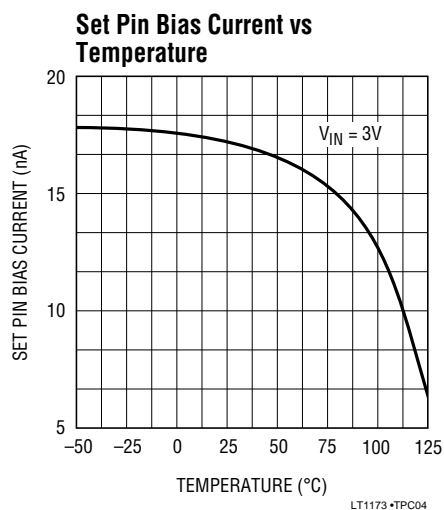
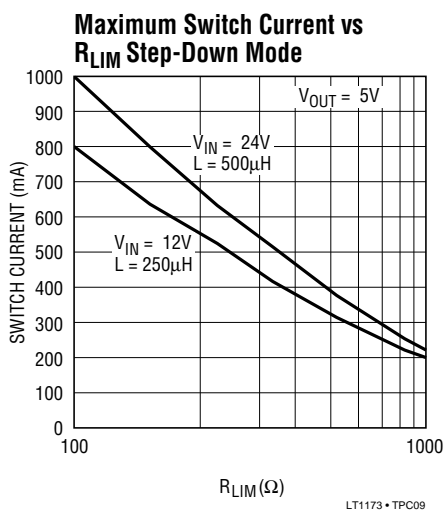
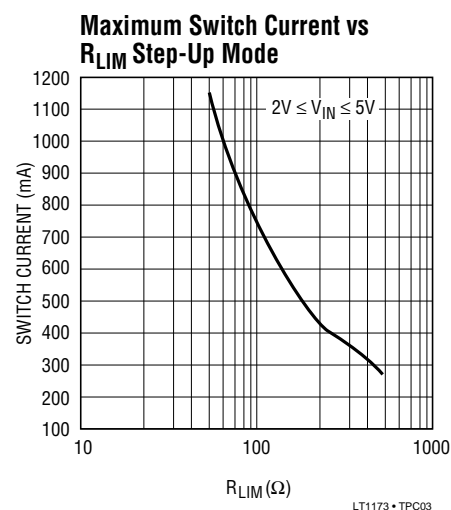
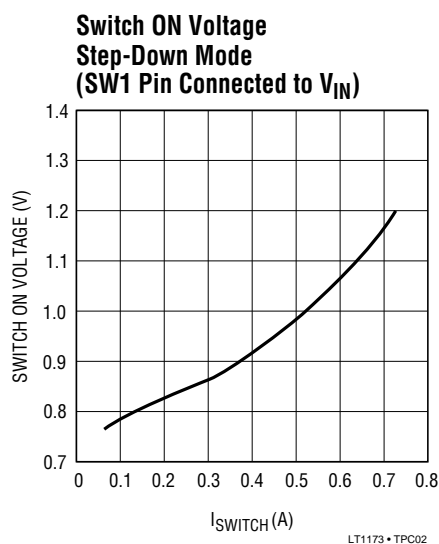
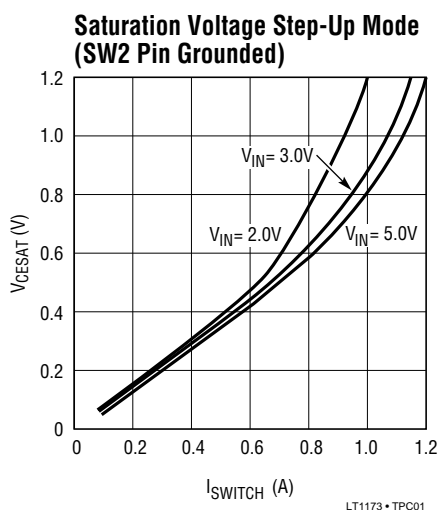

## TYPICAL PERFORMANCE CHARACTERISTICS

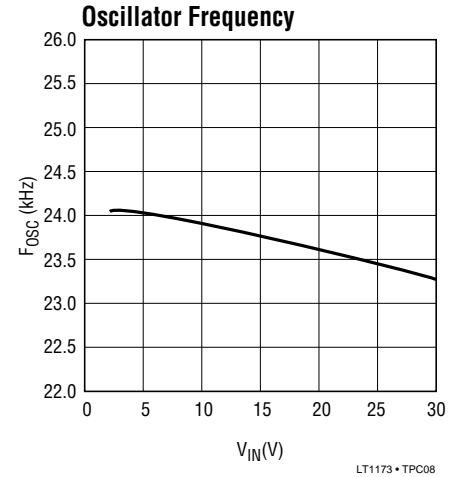
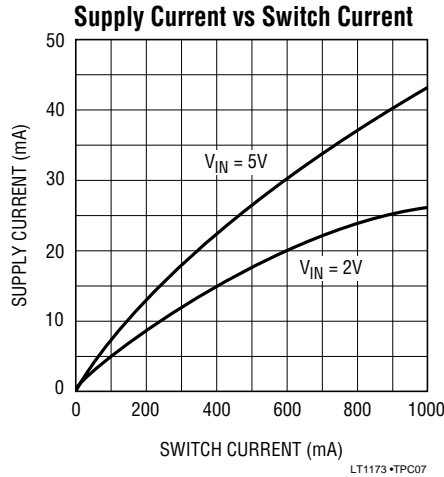
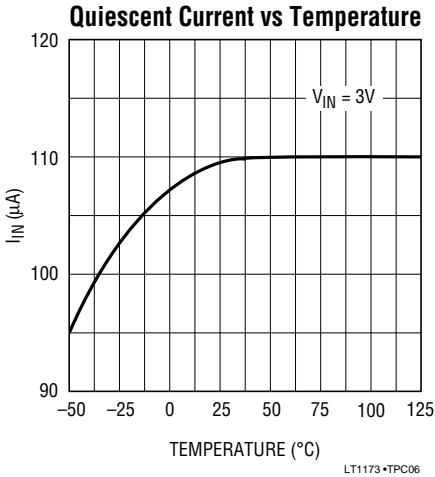

## PIN FUNCTIONS

**$I_{LIM}$  (Pin 1):** Connect this pin to  $V_{IN}$  for normal use. Where lower current limit is desired, connect a resistor between  $I_{LIM}$  and  $V_{IN}$ . A  $220\Omega$  resistor will limit the switch current to approximately 400mA.

**$V_{IN}$  (Pin 2):** Input supply voltage.

**SW1 (Pin 3):** Collector of power transistor. For step-up mode connect to inductor/diode. For step-down mode connect to  $V_{IN}$ .

**SW2 (Pin 4):** Emitter of power transistor. For step-up mode connect to ground. For step-down mode connect to inductor/diode. This pin must never be allowed to go more than a Schottky diode drop below ground.

**GND (Pin 5):** Ground.

**AO (Pin 6):** Auxiliary Gain Block (GB) output. Open collector, can sink  $100\mu A$ .

**SET (Pin 7):** GB input. GB is an op amp with positive input connected to SET pin and negative input connected to 1.245V reference.

**FB/SENSE (Pin 8):** On the LT1173 (adjustable) this pin goes to the comparator input. On the LT1173-5 and LT1173-12, this pin goes to the internal application resistor that sets output voltage.

## BLOCK DIAGRAMS

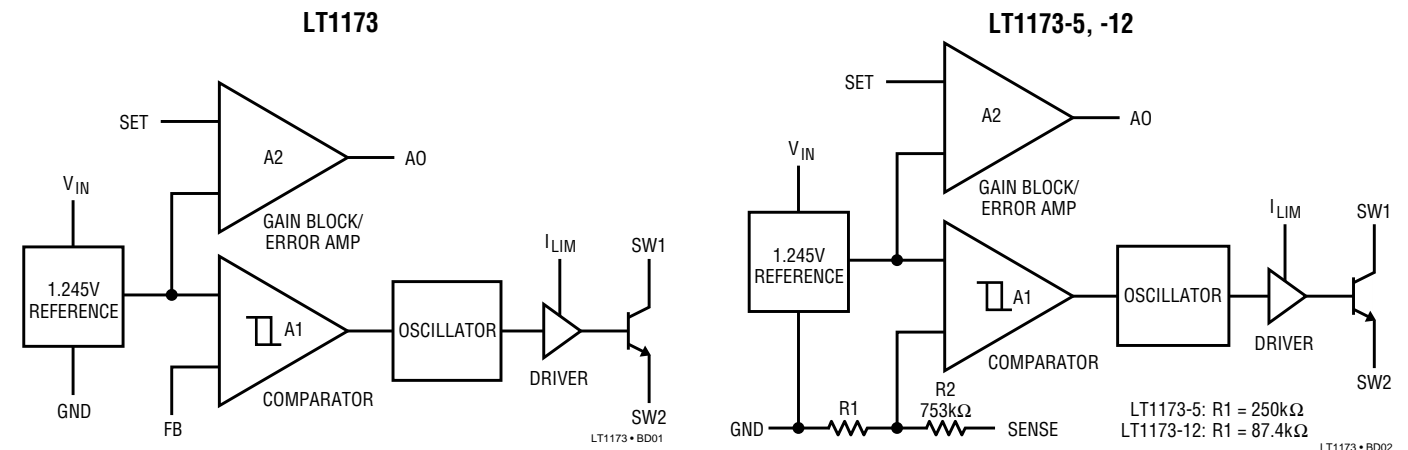

## LT1173 OPERATION

The LT1173 is a gated oscillator switcher. This type architecture has very low supply current because the switch is cycled only when the feedback pin voltage drops below the reference voltage. Circuit operation can best be understood by referring to the LT1173 block diagram. Comparator A1 compares the feedback pin voltage with the 1.245V reference voltage. When feedback drops below 1.245V, A1 switches on the 24kHz oscillator. The driver amplifier boosts the signal level to drive the output NPN power switch. An adaptive base drive circuit senses switch current and provides just enough base drive to ensure switch saturation without overdriving the switch, resulting in higher efficiency. The switch cycling action raises the output voltage and feedback pin voltage. When the feedback voltage is sufficient to trip A1, the oscillator is gated off. A small amount of hysteresis built into A1 ensures loop stability without external frequency compensation. When the comparator is low the oscillator and all high current circuitry is turned off, lowering device quiescent current to just 110 $\mu$ A, for the reference, A1 and A2.

The oscillator is set internally for 23 $\mu$ s ON time and 19 $\mu$ s OFF time, optimizing the device for circuits where  $V_{OUT}$  and  $V_{IN}$  differ by roughly a factor of 2. Examples include a 3V to 5V step-up converter or a 9V to 5V step-down converter.

A2 is a versatile gain block that can serve as a low battery detector, a linear post regulator, or drive an under voltage lockout circuit. The negative input of A2 is internally connected to the 1.245V reference. A resistor divider from  $V_{IN}$  to GND, with the mid-point connected to the SET pin provides the trip voltage in a low battery detector application. The gain block output (AO) can sink 100 $\mu$ A (use a 47k resistor pull-up to +5V). This line can signal a microcontroller that the battery voltage has dropped below the preset level.

A resistor connected between the  $I_{LIM}$  pin and  $V_{IN}$  sets maximum switch current. When the switch current exceeds the set value, the switch cycle is prematurely terminated. If current limit is not used,  $I_{LIM}$  should be tied directly to  $V_{IN}$ . Propagation delay through the current limit circuitry is approximately 2 $\mu$ s.

In step-up mode the switch emitter (SW2) is connected to ground and the switch collector (SW1) drives the inductor; in step-down mode the collector is connected to  $V_{IN}$  and the emitter drives the inductor.

The LT1173-5 and LT1173-12 are functionally identical to the LT1173. The -5 and -12 versions have on-chip voltage setting resistors for fixed 5V or 12V outputs. Pin 8 on the fixed versions should be connected to the output. No external resistors are needed.

## APPLICATIONS INFORMATION

### Measuring Input Current at Zero or Light Load

Obtaining meaningful numbers for quiescent current and efficiency at low output current involves understanding how the LT1173 operates. At very low or zero load current, the device is idling for seconds at a time. When the output voltage falls enough to trip the comparator, the power switch comes on for a few cycles until the output voltage rises sufficiently to overcome the comparator hysteresis. When the power switch is on, inductor current builds up to hundreds of milliamperes. Ordinary digital multimeters are not capable of measuring average current because of bandwidth and dynamic range limitations. A different

approach is required to measure the 100 $\mu$ A off-state and 500mA on-state currents of the circuit.

Quiescent current can be accurately measured using the circuit in Figure 1.  $V_{SET}$  is set to the input voltage of the LT1173. The circuit must be "booted" by shorting V2 to  $V_{SET}$ . After the LT1173 output voltage has settled, disconnect the short. Input voltage is V2, and average input current can be calculated by this formula:

$$I_{IN} = \frac{V2 - V1}{100\Omega} \quad (01)$$

## APPLICATIONS INFORMATION

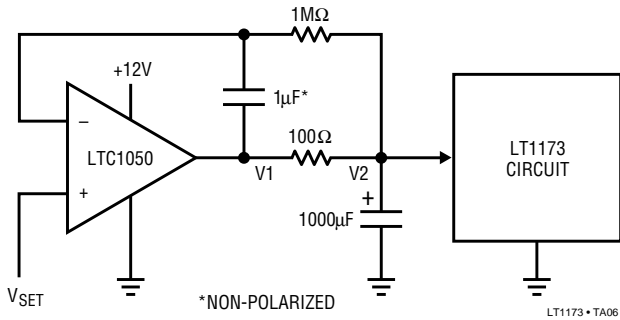

**Figure 1. Test Circuit Measures No Load Quiescent Current of LT1073 Converter**

### Inductor Selection

A DC-DC converter operates by storing energy as magnetic flux in an inductor core, and then switching this energy into the load. Since it is flux, not charge, that is stored, the output voltage can be higher, lower, or opposite in polarity to the input voltage by choosing an appropriate switching topology. To operate as an efficient energy transfer element, the inductor must fulfill three requirements. First, the inductance must be low enough for the inductor to store adequate energy under the worst case condition of minimum input voltage and switch ON time. The inductance must also be high enough so that maximum current ratings of the LT1173 and inductor are not exceeded at the other worst case condition of maximum input voltage and ON time. Additionally, the inductor core must be able to store the required flux; i.e., it must not *saturate*. At power levels generally encountered with LT1173 based designs, small axial leaded units with saturation current ratings in the 300mA to 1A range (depending on application) are adequate. Lastly, the inductor must have sufficiently low DC resistance so that excessive power is not lost as heat in the windings. An additional consideration is Electro-Magnetic Interference (EMI). Toroid and pot core type inductors are recommended in applications where EMI must be kept to a minimum; for example, where there are sensitive analog circuitry or transducers nearby. Rod core types are a less expensive choice where EMI is not a problem.

Specifying a proper inductor for an application requires first establishing minimum and maximum input voltage, output voltage, and output current. In a step-up converter,

the inductive events add to the input voltage to produce the output voltage. Power required from the inductor is determined by

$$P_L = (V_{OUT} + V_D - V_{IN}) (I_{OUT}) \quad (02)$$

where  $V_D$  is the diode drop (0.5V for a 1N5818 Schottky). Energy required by the inductor per cycle must be equal or greater than

$$\frac{P_L}{F_{OSC}} \quad (03)$$

in order for the converter to regulate the output.

When the switch is closed, current in the inductor builds according to

$$I_L(t) = \frac{V_{IN}}{R'} \left( 1 - e^{-\frac{R't}{L}} \right) \quad (04)$$

where  $R'$  is the sum of the switch equivalent resistance (0.8Ω typical at 25°C) and the inductor DC resistance. When the drop across the switch is small compared to  $V_{IN}$ , the simple lossless equation

$$I_L(t) = \frac{V_{IN}}{L} t \quad (05)$$

can be used. These equations assume that at  $t = 0$ , inductor current is zero. This situation is called “discontinuous mode operation” in switching regulator parlance. Setting “ $t$ ” to the switch ON time from the LT1173 specification table (typically 23μs) will yield  $i_{PEAK}$  for a specific “ $L$ ” and  $V_{IN}$ . Once  $i_{PEAK}$  is known, energy in the inductor at the end of the switch ON time can be calculated as

$$E_L = \frac{1}{2} Li_{PEAK}^2 \quad (06)$$

$E_L$  must be greater than  $P_L/F_{OSC}$  for the converter to deliver the required power. For best efficiency  $i_{PEAK}$  should be kept to 1A or less. Higher switch currents will cause excessive drop across the switch resulting in reduced efficiency. In general, switch current should be held to as low a value as possible in order to keep switch, diode and inductor losses at a minimum.



## APPLICATIONS INFORMATION

As an example, suppose 9V at 50mA is to be generated from a 3V input. Recalling Equation 02,

$$P_L = (9V + 0.5V - 3V) (50mA) = 325mW. \quad (07)$$

Energy required from the inductor is

$$\frac{P_L}{F_{OSC}} = \frac{325mW}{24kHz} = 13.5\mu J. \quad (08)$$

Picking an inductor value of 100 $\mu$ H with 0.2 $\Omega$  DCR results in a peak switch current of

$$i_{PEAK} = \frac{3V}{1\Omega} \left( 1 - e^{-\frac{1\Omega \bullet 23\mu s}{100\mu H}} \right) = 616mA. \quad (09)$$

Substituting  $i_{PEAK}$  into Equation 04 results in

$$E_L = \frac{1}{2} (100\mu H) (0.616A)^2 = 19.0\mu J. \quad (10)$$

Since 19 $\mu$ J > 13.5 $\mu$ J the 100 $\mu$ H inductor will work. This trial-and-error approach can be used to select the optimum inductor. Keep in mind the switch current maximum rating of 1.5A. If the calculated peak current exceeds this, consider using the LT1073. The 70% duty cycle of the LT1073 allows more energy per cycle to be stored in the inductor, resulting in more output power.

An inductor's energy storage capability is proportional to its physical size. If the size of the inductor is too large for a particular application, considerable size reduction is possible by using the LT1111. This device is pin compatible with the LT1173 but has a 72kHz oscillator, thereby reducing inductor and capacitor size requirements by a factor of three.

For both positive-to-negative (Figure 7) and negative-to-positive configurations (Figure 8), all the output power must be generated by the inductor. In these cases

$$P_L = (|V_{OUT}| + V_D) (I_{OUT}). \quad (11)$$

In the positive-to-negative case, switch drop can be modeled as a 0.75V voltage source in series with a 0.65 $\Omega$  resistor so that

$$V_L = V_{IN} - 0.75V - I_L (0.65\Omega). \quad (12)$$

In the negative-to-positive case, the switch saturates and the 0.8 $\Omega$  switch ON resistance value given for Equation 04 can be used. In both cases inductor design proceeds from Equation 03.

The step-down case is different than the preceding three in that the inductor current flows through the load in a step-down topology (Figure 6). Current through the switch should be limited to ~650mA in step-down mode. This can be accomplished by using the  $I_{LIM}$  pin. With input voltages in the range of 12V to 25V, a 5V output at 300mA can be generated with a 220 $\mu$ H inductor and 100 $\Omega$  resistor in series with the  $I_{LIM}$  pin. With a 20V to 30V input range, a 470 $\mu$ H inductor should be used along with the 100 $\Omega$  resistor.

### Capacitor Selection

Selecting the right output capacitor is almost as important as selecting the right inductor. A poor choice for a filter capacitor can result in poor efficiency and/or high output ripple. Ordinary aluminum electrolytics, while inexpensive and readily available, may have unacceptably poor equivalent series resistance (ESR) and ESL (inductance). There are low-ESR aluminum capacitors on the market specifically designed for switch mode DC-DC converters which work much better than general-purpose units. Tantalum capacitors provide still better performance at more expense. We recommend OS-CON capacitors from Sanyo Corporation (San Diego, CA). These units are physically quite small and have extremely low ESR. To illustrate, Figures 2, 3, and 4 show the output voltage of an LT1173 based converter with three 100 $\mu$ F capacitors. The peak switch current is 500mA in all cases. Figure 2 shows a Sprague 501D, 25V aluminum capacitor.  $V_{OUT}$  jumps by over 120mV when the switch turns off, followed by a drop in voltage as the inductor dumps into the capacitor. This works out to be an ESR of over 240m $\Omega$ . Figure 3 shows the same circuit, but with a Sprague 150D, 20V tantalum capacitor replacing the aluminum unit. Output jump is now about 35mV, corresponding to an ESR of 70m $\Omega$ . Figure 4 shows the circuit with a 16V OS-CON unit. ESR is now only 20m $\Omega$ .

## APPLICATIONS INFORMATION

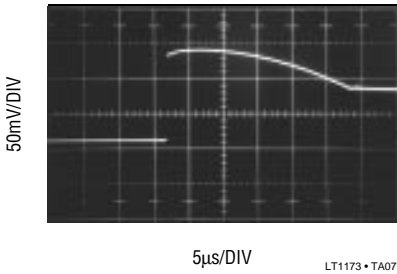

Figure 2. Aluminum

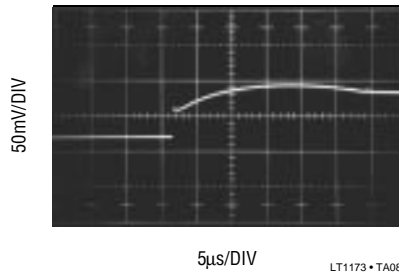

Figure 3. Tantalum

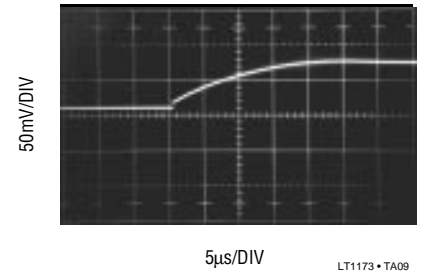

Figure 4. OS-CON

In very low power applications where every microampere is important, leakage current of the capacitor must be considered. The OS-CON units do have leakage current in the 5µA to 10µA range. If the load is also in the microampere range, a leaky capacitor will noticeably decrease efficiency. In this type application tantalum capacitors are the best choice, with typical leakage currents in the 1µA to 5µA range.

### Diode Selection

Speed, forward drop, and leakage current are the three main considerations in selecting a catch diode for LT1173 converters. General purpose rectifiers such as the 1N4001 are *unsuitable* for use in *any* switching regulator application. Although they are rated at 1A, the switching time of a 1N4001 is in the 10µs-50µs range. At best, efficiency will be severely compromised when these diodes are used; at worst, the circuit may not work at all. Most LT1173 circuits will be well served by a 1N5818 Schottky diode. The combination of 500mV forward drop at 1A current, fast turn ON and turn OFF time, and 4µA to 10µA leakage current fit nicely with LT1173 requirements. At peak switch currents of 100mA or less, a 1N4148 signal diode may be used. This diode has leakage current in the 1nA-5nA range at 25°C and lower cost than a 1N5818. (You can also use them to get your circuit up and running, but beware of destroying the diode at 1A switch currents.) In situations where the load is intermittent and the LT1173 is idling most of the time, battery life can sometimes be extended by using a silicon diode such as the 1N4933, which can handle 1A but has leakage current of less than 1µA. Efficiency will decrease somewhat compared to a 1N5818 while delivering power, but the lower idle current may be more important.

### Step-Up (Boost Mode) Operation

A step-up DC-DC converter delivers an output voltage higher than the input voltage. Step-up converters are *not* short circuit protected since there is a DC path from input to output.

The usual step-up configuration for the LT1173 is shown in Figure 5. The LT1173 first pulls SW1 low causing  $V_{IN} - V_{CESAT}$  to appear across L1. A current then builds up in L1. At the end of the switch ON time the current in L1 is<sup>1</sup>:

$$i_{PEAK} = \frac{V_{IN}}{L} t_{ON} \quad (13)$$

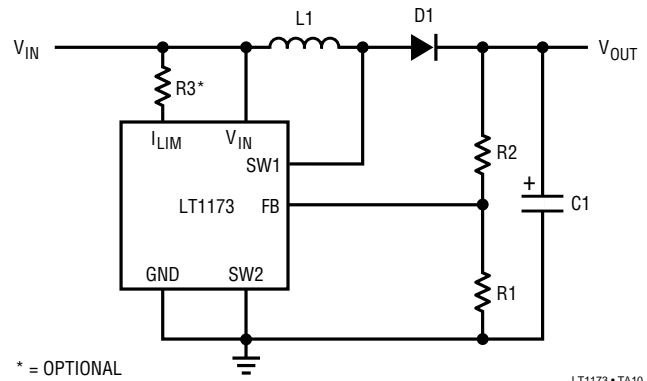

Figure 5. Step-Up Mode Hookup. Refer to Table 1 for Component Values

Immediately after switch turn off, the SW1 voltage pin starts to rise because current cannot instantaneously stop flowing in L1. When the voltage reaches  $V_{OUT} + V_D$ , the inductor current flows through D1 into C1, increasing  $V_{OUT}$ . This action is repeated as needed by the LT1173 to

**Note 1:** This simple expression neglects the effect of switch and coil resistance. This is taken into account in the “Inductor Selection” section.



## APPLICATIONS INFORMATION

keep  $V_{FB}$  at the internal reference voltage of 1.245V.  $R_1$  and  $R_2$  set the output voltage according to the formula

$$V_{OUT} = \left(1 + \frac{R_2}{R_1}\right)(1.245V). \quad (14)$$

### Step-Down (Buck Mode) Operation

A step-down DC-DC converter converts a higher voltage to a lower voltage. The usual hookup for an LT1173 based step-down converter is shown in Figure 6.

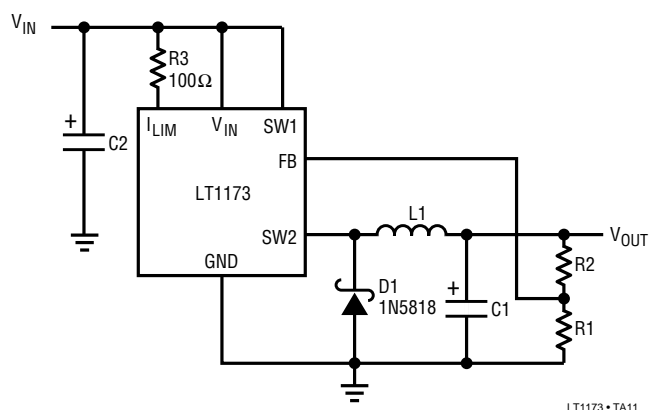

Figure 6. Step-Down Mode Hookup

When the switch turns on, SW2 pulls up to  $V_{IN} - V_{SW}$ . This puts a voltage across  $L_1$  equal to  $V_{IN} - V_{SW} - V_{OUT}$ , causing a current to build up in  $L_1$ . At the end of the switch ON time, the current in  $L_1$  is equal to

$$i_{PEAK} = \frac{V_{IN} - V_{SW} - V_{OUT}}{L} t_{ON}. \quad (15)$$

When the switch turns off, the SW2 pin falls rapidly and actually goes below ground.  $D_1$  turns on when SW2 reaches 0.4V below ground. *D1 MUST BE A SCHOTTKY DIODE*. The voltage at SW2 must never be allowed to go below -0.5V. A silicon diode such as the 1N4933 will allow SW2 to go to -0.8V, causing potentially destructive power dissipation inside the LT1173. Output voltage is determined by

$$V_{OUT} = \left(1 + \frac{R_2}{R_1}\right)(1.245V). \quad (16)$$

$R_3$  programs switch current limit. This is especially important in applications where the input varies over a wide range. Without  $R_3$ , the switch stays on for a fixed time each cycle. Under certain conditions the current in  $L_1$  can build up to excessive levels, exceeding the switch rating and/or saturating the inductor. The 100Ω resistor programs the switch to turn off when the current reaches approximately 800mA. When using the LT1173 in step-down mode, output voltage should be limited to 6.2V or less. Higher output voltages can be accommodated by inserting a 1N5818 diode in series with the SW2 pin (anode connected to SW2).

### Inverting Configurations

The LT1173 can be configured as a positive-to-negative converter (Figure 7), or a negative-to-positive converter (Figure 8). In Figure 7, the arrangement is very similar to a step-down, except that the high side of the feedback is referred to ground. This level shifts the output negative. As in the step-down mode,  $D_1$  must be a Schottky diode, and  $|V_{OUT}|$  should be less than 6.2V. More negative output voltages can be accommodated as in the prior section.

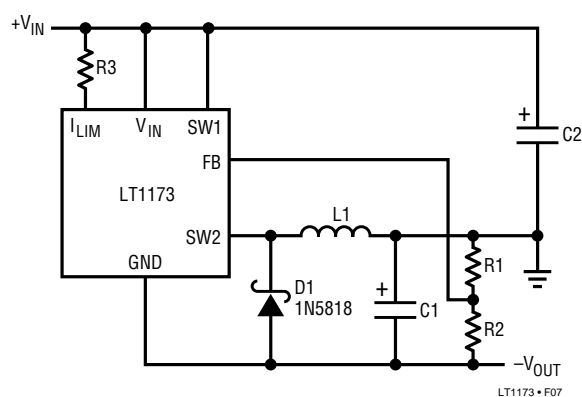

Figure 7. Positive-to-Negative Converter

In Figure 8, the input is negative while the output is positive. In this configuration, the magnitude of the input voltage can be higher or lower than the output voltage. A level shift, provided by the PNP transistor, supplies proper polarity feedback information to the regulator.

APPLICATIONS INFORMATION

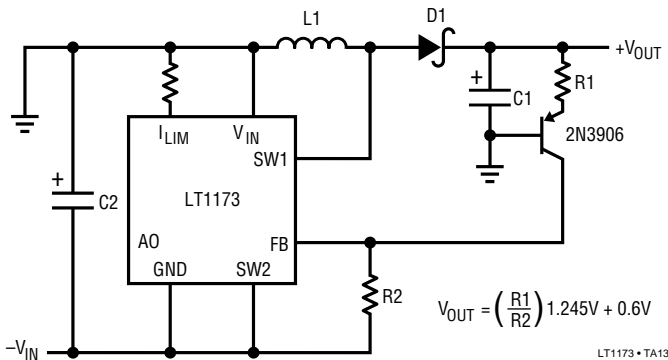

Figure 8. Negative-to-Positive Converter

Using the I<sub>LIM</sub> Pin

The LT1173 switch can be programmed to turn off at a set switch current, a feature not found on competing devices. This enables the input to vary over a wide range without exceeding the maximum switch rating or saturating the inductor. Consider the case where analysis shows the LT1173 must operate at an 800mA peak switch current with a 2.0V input. If V<sub>IN</sub> rises to 4V, the peak switch current will rise to 1.6A, exceeding the maximum switch current rating. With the proper resistor selected (see the “Maximum Switch Current vs R<sub>LIM</sub>” characteristic), the switch current will be limited to 800mA, even if the input voltage increases.

Another situation where the I<sub>LIM</sub> feature is useful occurs when the device goes into continuous mode operation. This occurs in step-up mode when

$$\frac{V_{OUT} + V_{DIODE}}{V_{IN} - V_{SW}} < \frac{1}{1 - DC} \tag{17}$$

When the input and output voltages satisfy this relationship, inductor current does not go to zero during the switch OFF time. When the switch turns on again, the current ramp starts from the non-zero current level in the inductor just prior to switch turn on. As shown in Figure 9, the inductor current increases to a high level before the comparator turns off the oscillator. This high current can cause excessive output ripple and requires oversizing the output capacitor and inductor. With the I<sub>LIM</sub> feature, however, the switch current turns off at a programmed level as shown in Figure 10, keeping output ripple to a minimum.

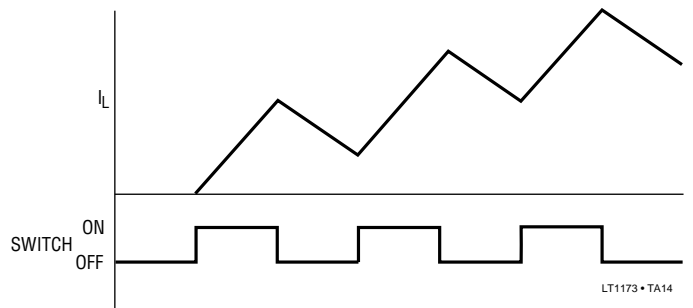

Figure 9. No Current Limit Causes Large Inductor Current Build-Up

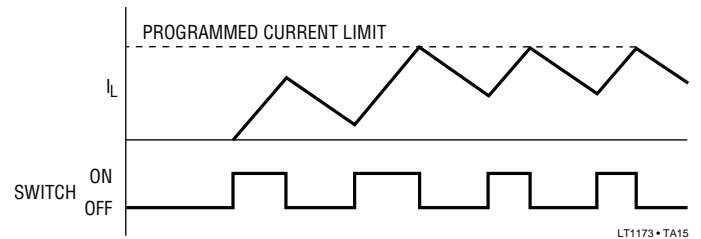

Figure 10. Current Limit Keeps Inductor Current Under Control

Figure 11 details current limit circuitry. Sense transistor Q1, whose base and emitter are paralleled with power switch Q2, is ratioed such that approximately 0.5% of Q2’s collector current flows in Q1’s collector. This current is passed through internal 80Ω resistor R1 and out through the I<sub>LIM</sub> pin. The value of the external resistor connected between I<sub>LIM</sub> and V<sub>IN</sub> sets the current limit. When sufficient switch current flows to develop a V<sub>BE</sub> across R1 + R<sub>LIM</sub>, Q3 turns on and injects current into the oscillator, turning off the switch. Delay through this circuitry is approximately 2μs. The current trip point becomes less accurate for switch ON times less than 4μs. Resistor values programming switch ON time for 2μs or less will cause spurious response in the switch circuitry although the device will still maintain output regulation.

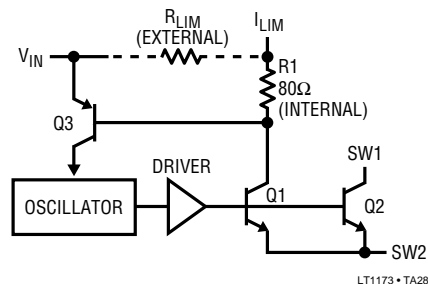

Figure 11. LT1173 Current Limit Circuitry

## APPLICATIONS INFORMATION

### Using the Gain Block

The gain block (GB) on the LT1173 can be used as an error amplifier, low battery detector or linear post regulator. The gain block itself is a very simple PNP input op amp with an open collector NPN output. The negative input of the gain block is tied internally to the 1.245V reference. The positive input comes out on the SET pin.

Arrangement of the gain block as a low battery detector is straightforward. Figure 12 shows hookup. R1 and R2 need only be low enough in value so that the bias current of the SET input does not cause large errors. 100kΩ for R2 is adequate. R3 can be added to introduce a small amount of hysteresis. This will cause the gain block to “snap” when the trip point is reached. Values in the 1M-10M range are optimal. The addition of R3 will change the trip point, however.

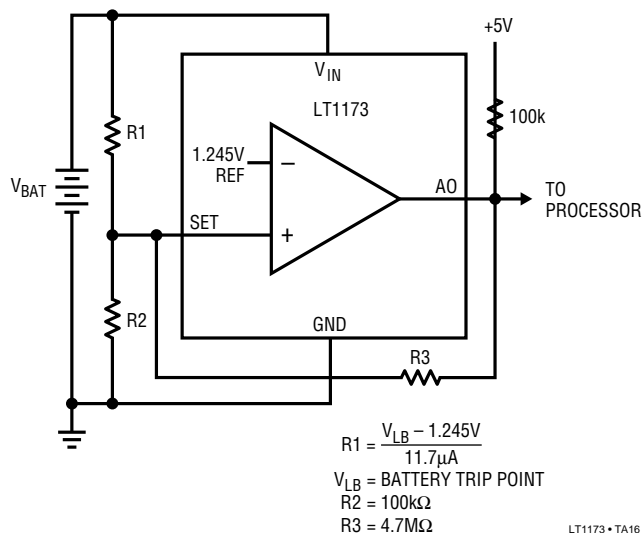

Figure 12. Setting Low Battery Detector Trip Point

Table 1. Component Selection for Common Converters

INPUT VOLTAGE	OUTPUT VOLTAGE	OUTPUT CURRENT (MIN)	CIRCUIT FIGURE	INDUCTOR VALUE	INDUCTOR PART NUMBER	CAPACITOR VALUE	NOTES
2.0-3.1	5	90mA	5	47μH	G GA10-472K, C CTX50-1	100μF	*
2.0-3.1	5	10mA	5	220μH	G GA10-223K, C CTX	22μF	
2.0-3.1	12	50mA	5	47μH	G GA10-472K, C CTX50-1	47μF	*
2.0-3.1	12	10mA	5	150μH	G GA10-153K	22μF	
5	12	90mA	5	120μH	G GA10-123K	100μF	
5	12	30mA	5	150μH	G GA10-153K	47μF	**
5	15	50mA	5	120μH	G GA10-123K C CTX100-4	47μF	
5	30	25mA	5	100μH	G GA10-103K, C CTX100-4	10μF, 50V	
6.5-9.5	5	50mA	6	47μH	G GA10-472K, C CTX50-1	100μF	**
12-20	5	300mA	6	220μH	G GA20-223K	220μF	**
20-30	5	300mA	6	470μH	G GA20-473K	470μF	**
5	-5	75mA	7	100μH	G GA10-103K, C CTX100-4	100μF	**
12	-5	250mA	7	470μH	G GA40-473K	220μF	**
-5	5	150mA	8	100μH	G GA10-103K, C CTX100-4	220μF	
-5	12	75mA	8	100μH	G GA10-103K, C CTX100-4	47μF	

G = Gowanda

C = Coiltronics

\* Add 68Ω from I<sub>LIM</sub> to V<sub>IN</sub>

\*\* Add 100Ω from I<sub>LIM</sub> to V<sub>IN</sub>

## APPLICATIONS INFORMATION

**Table 2. Inductor Manufacturers**

MANUFACTURER	PART NUMBERS
Gowanda Electronics Corporation 1 Industrial Place Gowanda, NY 14070 716-532-2234	GA10 Series GA40 Series
Caddell-Burns 258 East Second Street Mineola, NY 11501 516-746-2310	7300 Series 6860 Series
Coiltronics International 984 S.W. 13th Court Pompano Beach, FL 33069 305-781-8900	Custom Toroids Surface Mount
Renco Electronics Incorporated 60 Jefryn Boulevard, East Deer Park, NY 11729 800-645-5828	RL1283 RL1284

**Table 3. Capacitor Manufacturers**

MANUFACTURER	PART NUMBERS
Sanyo Video Components 2001 Sanyo Avenue San Diego, CA 92173 619-661-6835	OS-CON Series
Nichicon America Corporation 927 East State Parkway Schaumburg, IL 60173 708-843-7500	PL Series
Sprague Electric Company Lower Main Street Sanford, ME 04073 207-324-4140	150D Solid Tantalums 550D Tantalex

## TYPICAL APPLICATIONS

**3V to -22V LCD Bias Generator**

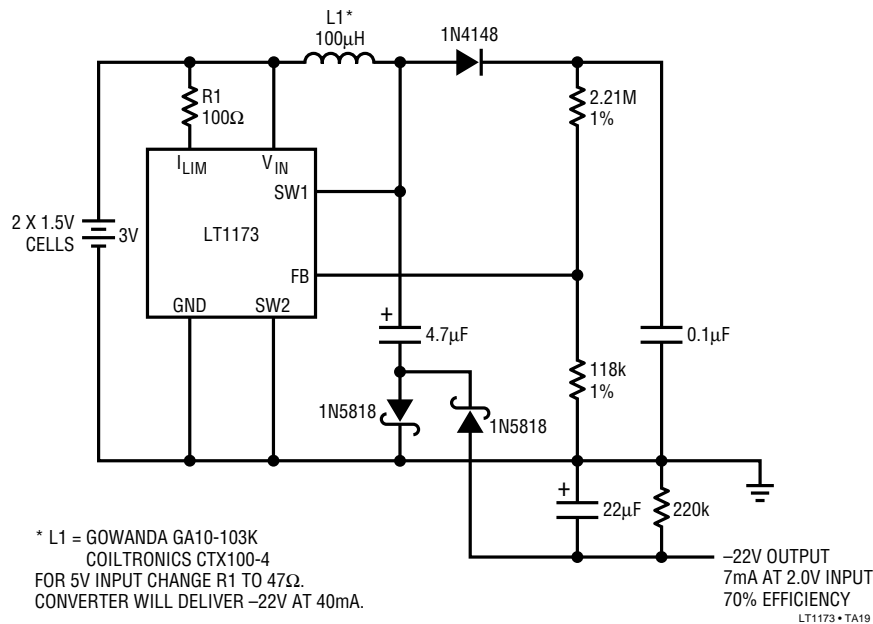

# TYPICAL APPLICATIONS

**3V to 5V Step-Up Converter**

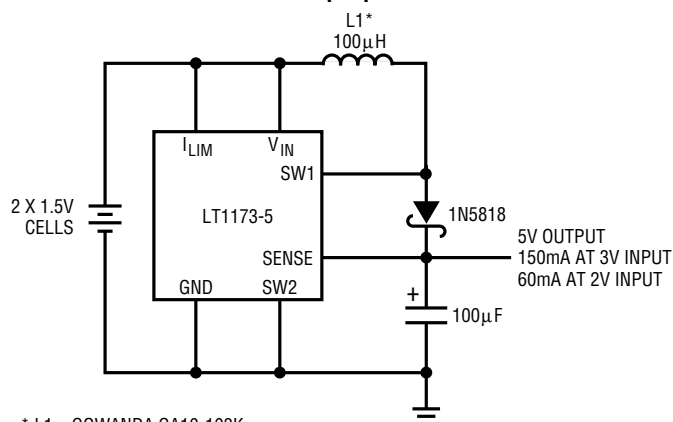

\* L1 = GOWANDA GA10-103K  
COILTRONICS CTX100-1 (SURFACE MOUNT)

LT1173 • TA17

**9V to 5V Step-Down Converter**

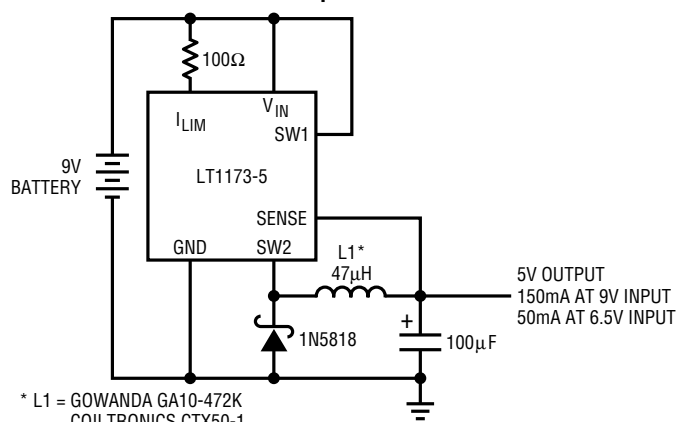

\* L1 = GOWANDA GA10-472K  
COILTRONICS CTX50-1  
FOR HIGHER OUTPUT CURRENTS SEE LT1073 DATASHEET

LT1173 • TA18

**+5V to -5V Converter**

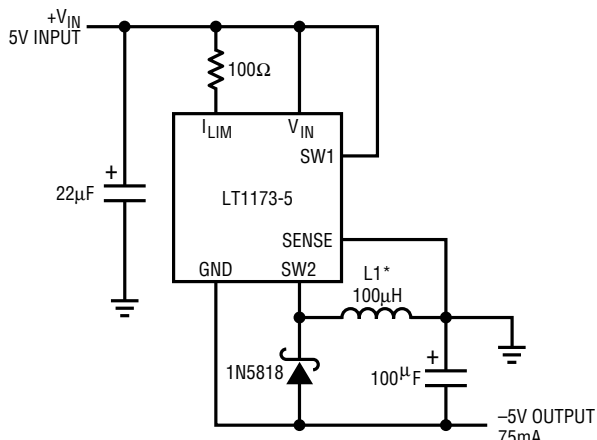

\* L1 = GOWANDA GA10-103K  
COILTRONICS CTX100-1

LT1173 • TA20

**+20V to 5V Step-Down Converter**

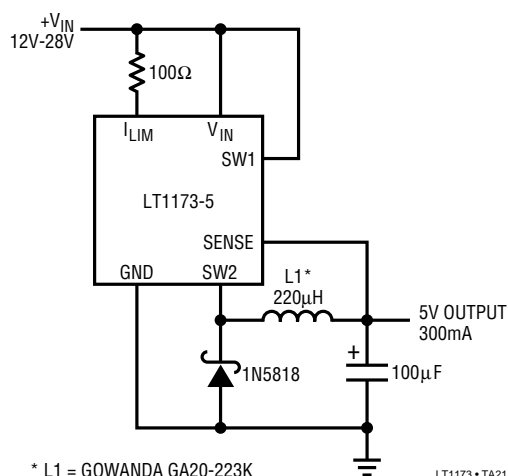

\* L1 = GOWANDA GA20-223K

LT1173 • TA21

**Telecom Supply**

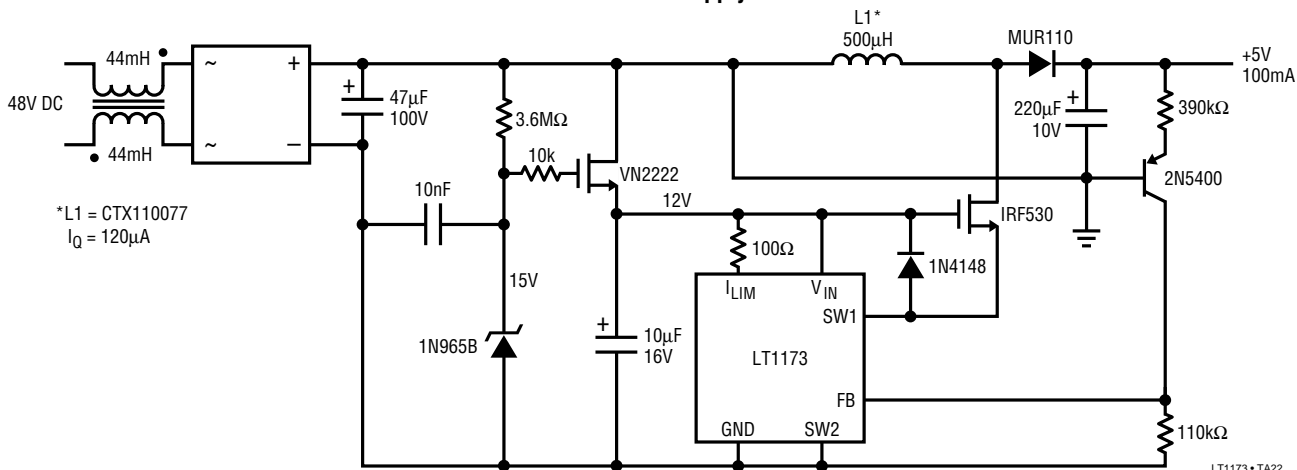

\* L1 = CTX110077  
I<sub>Q</sub> = 120µA

LT1173 • TA22

TYPICAL APPLICATIONS

“5 to 5” Step-Up or Step-Down Converter

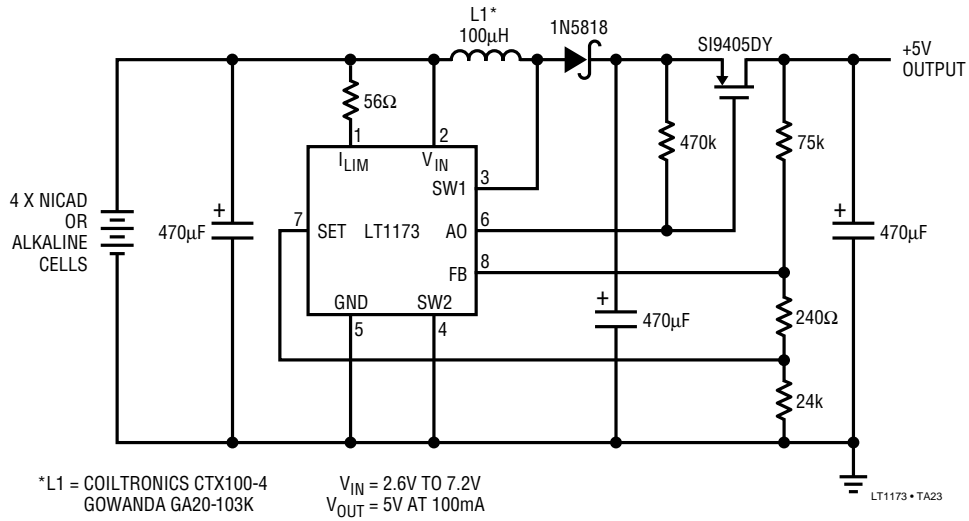

2V to 5V at 300mA Step-Up Converter with Under Voltage Lockout

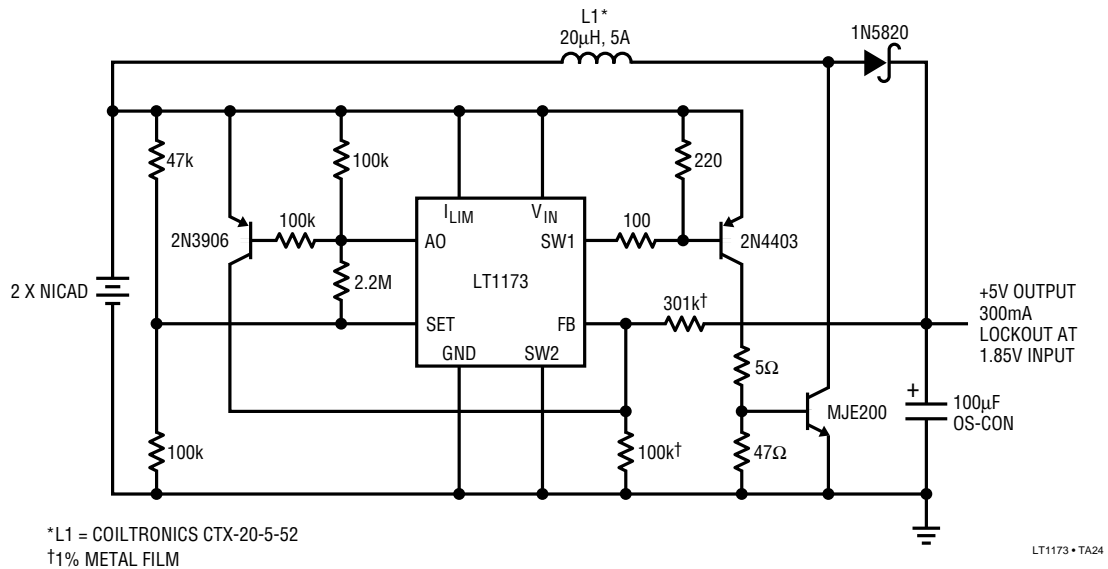



# TYPICAL APPLICATIONS

### Voltage Controlled Positive-to-Negative Converter

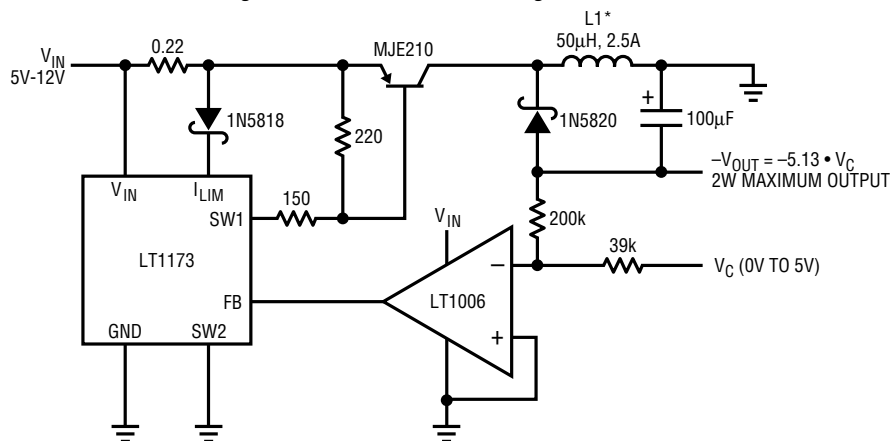

\* L1 = GOWANDA GT10-101

LT1173 • TA25

### High Power, Low Quiescent Current Step-Down Converter

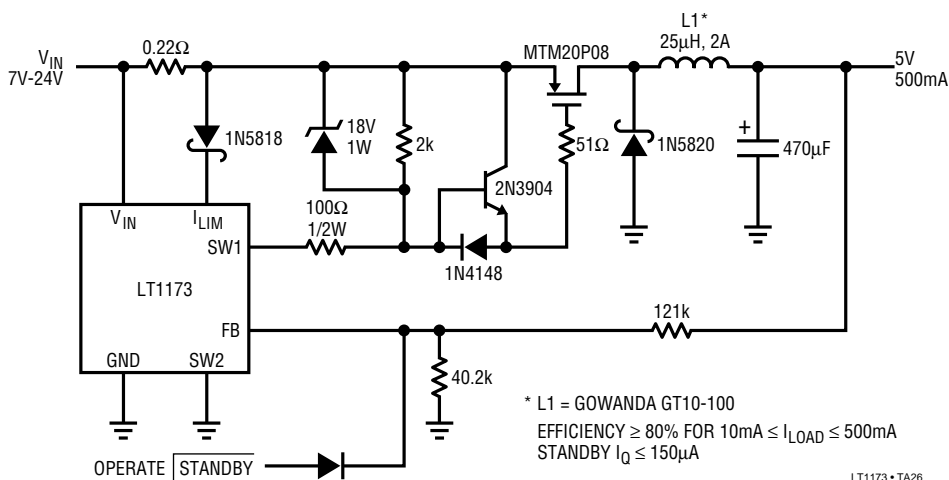

\* L1 = GOWANDA GT10-100  
 EFFICIENCY ≥ 80% FOR 10mA ≤ I<sub>LOAD</sub> ≤ 500mA  
 STANDBY I<sub>Q</sub> ≤ 150μA

LT1173 • TA26

### 2 Cell Powered Neon Light Flasher

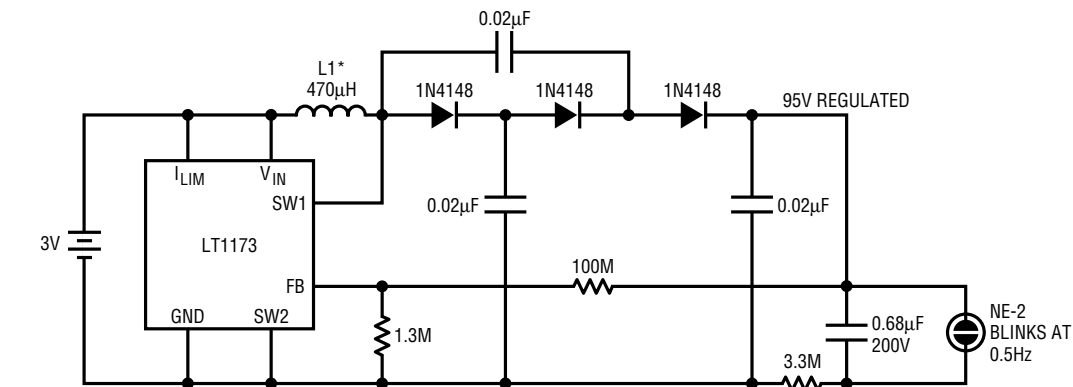

\*TOKO 262LYF-0100K

LT1173 • TA27

**PACKAGE DESCRIPTION** Dimensions in inches (millimeters) unless otherwise noted.

**N8 Package  
8-Lead Plastic DIP**

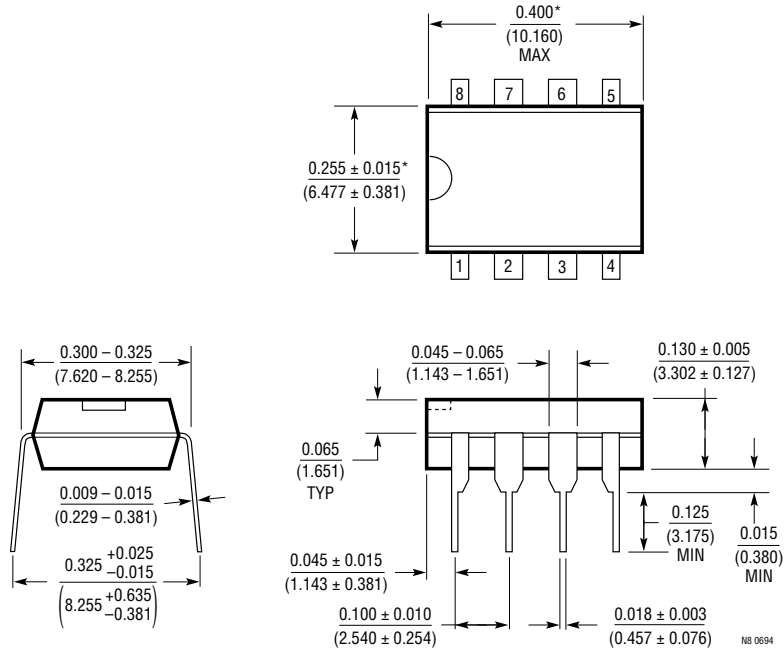

\*THESE DIMENSIONS DO NOT INCLUDE MOLD FLASH OR PROTRUSIONS. MOLD FLASH OR PROTRUSIONS SHALL NOT EXCEED 0.010 INCH (0.254mm).

**S8 Package  
8-Lead Plastic SOIC**

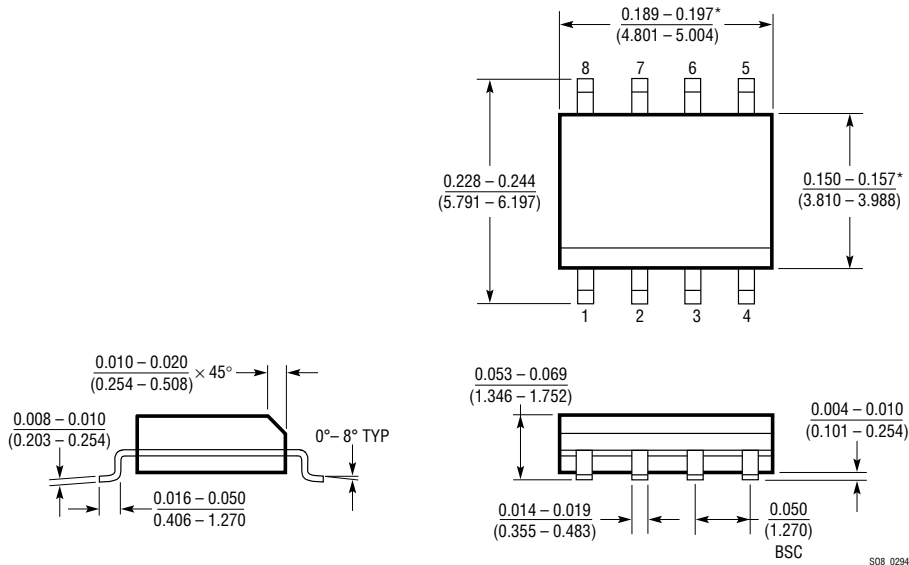

\*THESE DIMENSIONS DO NOT INCLUDE MOLD FLASH OR PROTRUSIONS. MOLD FLASH OR PROTRUSIONS SHALL NOT EXCEED 0.006 INCH (0.15mm).