

Micropower DC-DC Converter

Adjustable and Fixed 5V, 12V

FEATURES

- Operates at Supply Voltages From 1.0V to 30V
- Works in Step-Up or Step-Down Mode
- Only Three External Off-the-Shelf Components Required
- Low-Battery Detector Comparator On-Chip
- User-Adjustable Current Limit
- Internal 1A Power Switch
- Fixed or Adjustable Output Voltage Versions
- Space-Saving 8-Pin MiniDIP or S8 Package

APPLICATIONS

- Pagers
- Cameras
- Single-Cell to 5V Converters
- Battery Backup Supplies
- Laptop and Palmtop Computers
- Cellular Telephones
- Portable Instruments
- Laser Diode Drivers
- Hand-Held Inventory Computers

DESCRIPTION

The LT1110 is a versatile micropower DC-DC converter. The device requires only three external components to deliver a fixed output of 5V or 12V. The very low minimum supply voltage of 1.0V allows the use of the LT1110 in applications where the primary power source is a single cell. An on-chip auxiliary gain block can function as a low battery detector or linear post regulator.

The 70kHz oscillator allows the use of surface mount inductors and capacitors in many applications. Quiescent current is just 300 μ A, making the device ideal in remote or battery powered applications where current consumption must be kept to a minimum.

The device can easily be configured as a step-up or step-down converter, although for most step-down applications or input sources greater than 3V, the LT1111 is recommended. Switch current limiting is user-adjustable by adding a single external resistor. Unique reverse battery protection circuitry limits reverse current to safe, non-destructive levels at reverse supply voltages up to 1.6V.

TYPICAL APPLICATION

All Surface Mount
Single Cell to 5V Converter

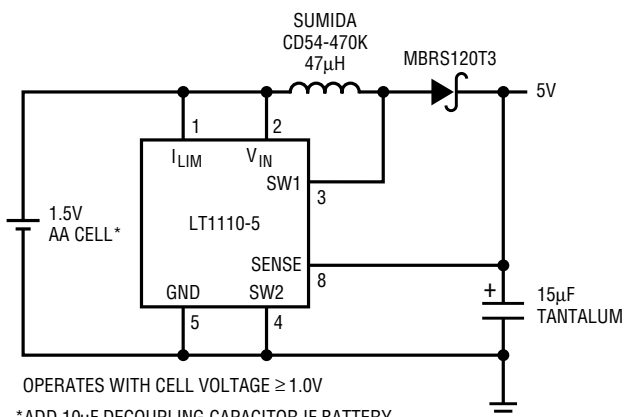

OPERATES WITH CELL VOLTAGE $\geq 1.0V$

*ADD 10 μ F DECOUPLING CAPACITOR IF BATTERY IS MORE THAN 2" AWAY FROM LT1110.

LT1110 • TA01

Efficiency

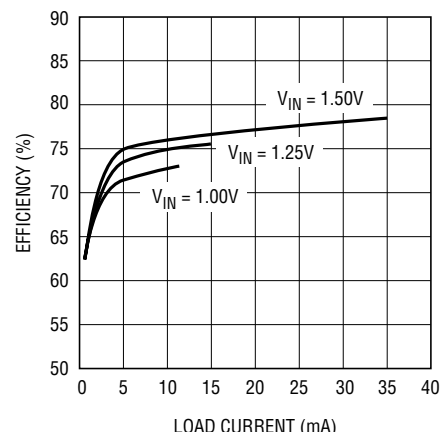

LT1110 • TA02

ABSOLUTE MAXIMUM RATINGS

Supply Voltage, Step-Up Mode	15V
Supply Voltage, Step-Down Mode	36V
SW1 Pin Voltage	50V
SW2 Pin Voltage	-0.5V to V_{IN}
Feedback Pin Voltage (LT1110)	5.5V
Switch Current	1.5A
Maximum Power Dissipation	500mW
Operating Temperature Range	0°C to 70°C
Storage Temperature Range	-65°C to 150°C
Lead Temperature (Soldering, 10 sec.)	300°C

PACKAGE/ORDER INFORMATION

	ORDER PART NUMBER
	LT1110CN8 LT1110CN8-5 LT1110CN8-12
	LT1110CS8 LT1110CS8-5 LT1110CS8-12
	S8 PART MARKING
	1110 11105 11012

Consult factory for Industrial and Military grade parts.

ELECTRICAL CHARACTERISTICS $T_A = 25^\circ\text{C}$, $V_{IN} = 1.5\text{V}$, unless otherwise noted.

SYMBOL	PARAMETER	CONDITIONS	MIN	TYP	MAX	UNITS	
I_Q	Quiescent Current	Switch Off	●	300		μA	
V_{IN}	Input Voltage	Step-Up Mode	●	1.15 1.0	12.6 12.6	V V	
		Step-Down Mode	●		30	V	
V_{OUT}	Comparator Trip Point Voltage	LT1110 (Note 1)	●	210	220	230	mV
	Output Sense Voltage	LT1110-5 (Note 2)	●	4.75	5.00	5.25	V
		LT1110-12 (Note 2)	●	11.4	12.00	12.6	V
	Comparator Hysteresis	LT1110	●	4	8	mV	
	Output Hysteresis	LT1110-5	●	90	180	mV	
		LT1110-12	●	200	400	mV	
f_{OSC}	Oscillator Frequency		●	52	70	90	kHz
DC	Duty Cycle	Full Load ($V_{FB} < V_{REF}$)	●	62	69	78	%
t_{ON}	Switch ON Time		●	7.5	10	12.5	μs
I_{FB}	Feedback Pin Bias Current	LT1110, $V_{FB} = 0\text{V}$	●	70	150	nA	
I_{SET}	Set Pin Bias Current	$V_{SET} = V_{REF}$	●	100	300	nA	
V_{AO}	AO Output Low	$I_{AO} = -300\mu\text{A}$, $V_{SET} = 150\text{mV}$	●	0.15	0.4	V	
	Reference Line Regulation	$1.0\text{V} \leq V_{IN} \leq 1.5\text{V}$	●	0.35	1.0	%/V	
		$1.5\text{V} \leq V_{IN} \leq 12\text{V}$	●	0.05	0.1	%/V	

ELECTRICAL CHARACTERISTICS $T_A = 25^\circ\text{C}$, $V_{IN} = 1.5\text{V}$, unless otherwise noted.

SYMBOL	PARAMETER	CONDITIONS	MIN	TYP	MAX	UNITS
V_{CESAT}	Switch Saturation Voltage Step-Up Mode	$V_{IN} = 1.5\text{V}$, $I_{SW} = 400\text{mA}$	●	300	400	mV
		$V_{IN} = 1.5\text{V}$, $I_{SW} = 500\text{mA}$	●	400	550	mV
		$V_{IN} = 5\text{V}$, $I_{SW} = 1\text{A}$		700	1000	mV
A_V	A2 Error Amp Gain	$R_L = 100\text{k}\Omega$ (Note 3)	●	1000	5000	V/V
I_{REV}	Reverse Battery Current	(Note 4)		750		mA
I_{LIM}	Current Limit	220Ω Between I_{LIM} and V_{IN}		400		mA
	Current Limit Temperature Coefficient			-0.3		%/ $^\circ\text{C}$
I_{LEAK}	Switch OFF Leakage Current	Measured at SW1 Pin		1	10	μA
V_{SW2}	Maximum Excursion Below GND	$I_{SW1} \leq 10\mu\text{A}$, Switch Off		-400	-350	mV

The ● denotes the specifications which apply over the full operating temperature range.

Note 1: This specification guarantees that both the high and low trip point of the comparator fall within the 210mV to 230mV range.

Note 2: This specification guarantees that the output voltage of the fixed versions will always fall within the specified range. The waveform at the sense pin will exhibit a sawtooth shape due to the comparator hysteresis.

Note 3: 100k Ω resistor connected between a 5V source and the AO pin.

Note 4: The LT1110 is guaranteed to withstand continuous application of +1.6V applied to the GND and SW2 pins while V_{IN} , I_{LIM} , and SW1 pins are grounded.

TYPICAL PERFORMANCE CHARACTERISTICS

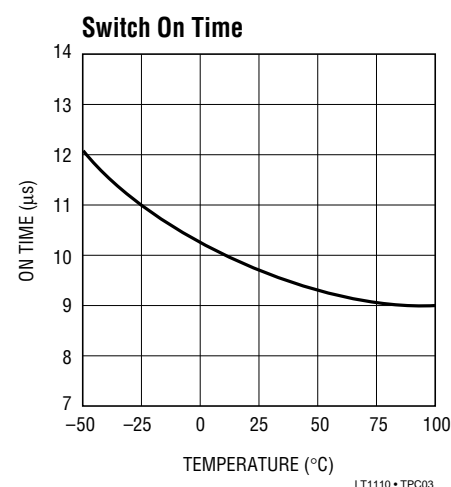
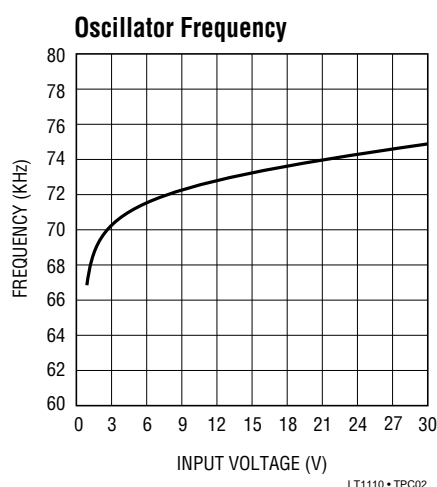
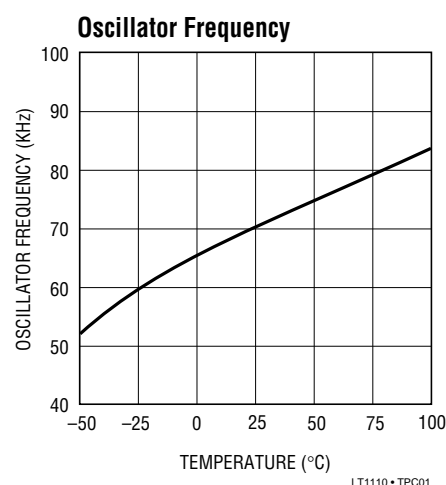

TYPICAL PERFORMANCE CHARACTERISTICS

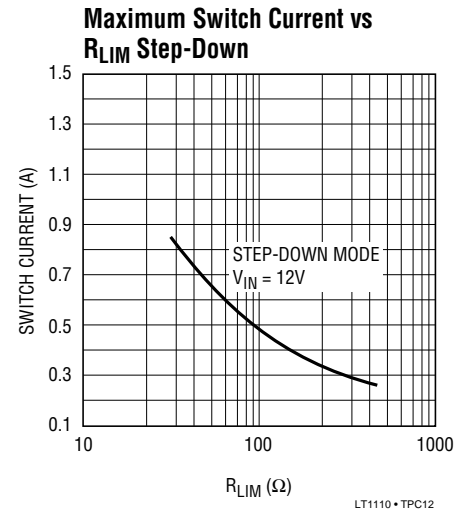
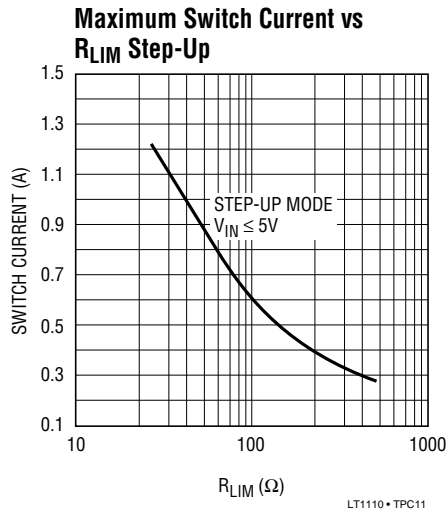
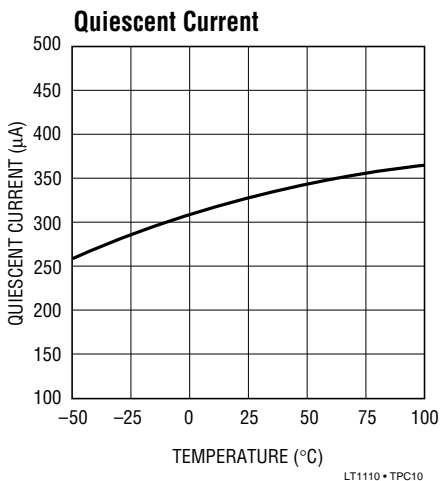
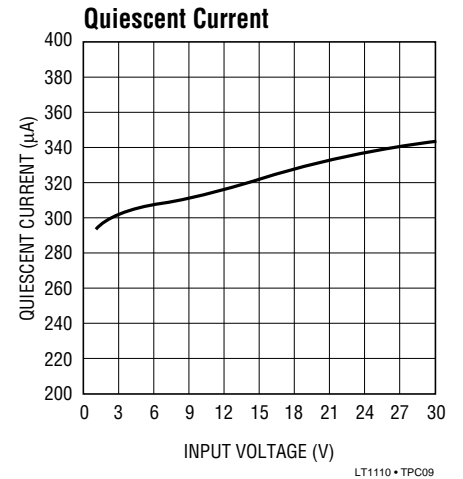
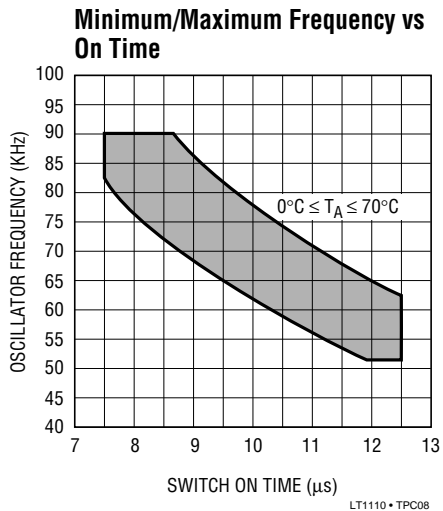
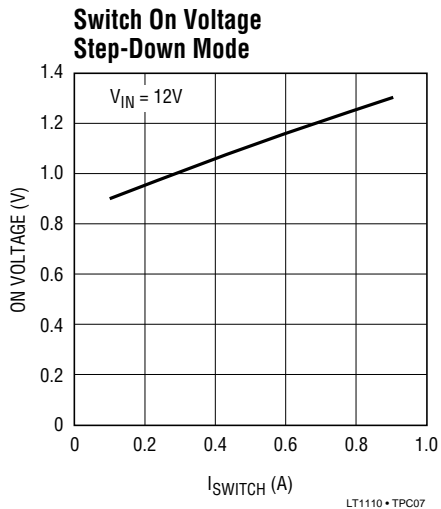
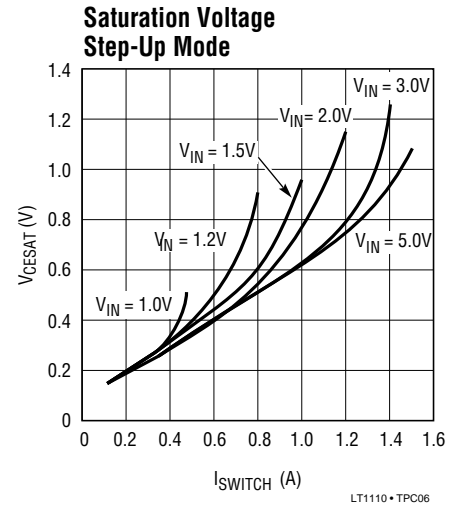
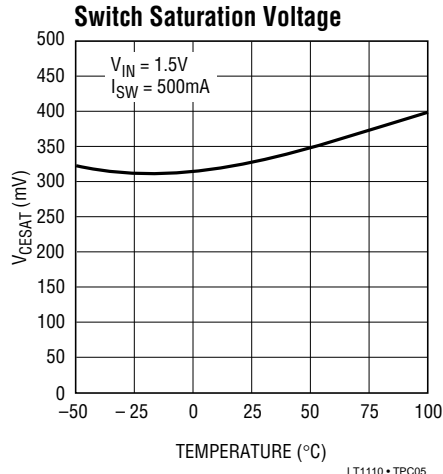
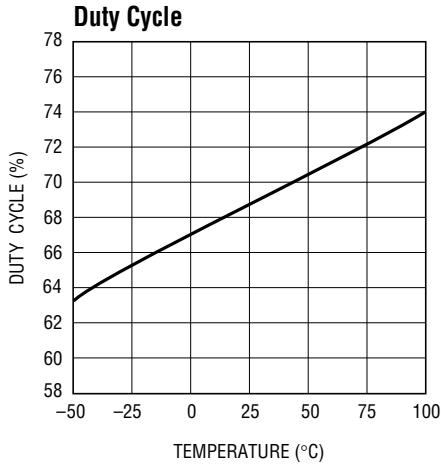

TYPICAL PERFORMANCE CHARACTERISTICS

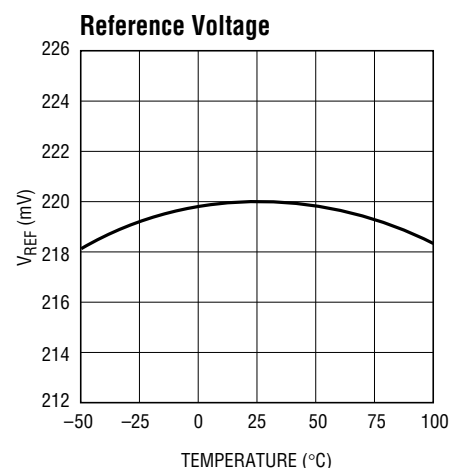
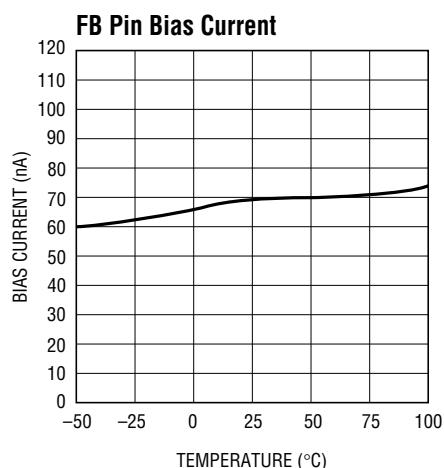
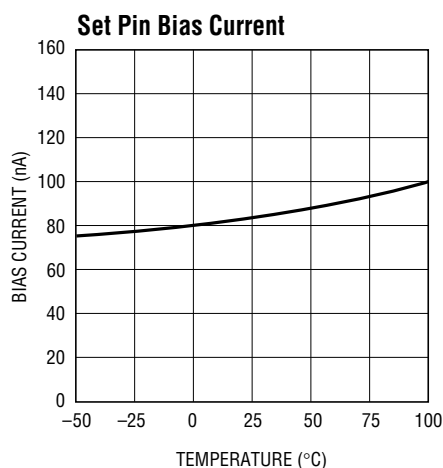

PIN FUNCTIONS

I_{LIM} (Pin 1): Connect this pin to V_{IN} for normal use. Where lower current limit is desired, connect a resistor between I_{LIM} and V_{IN} . A 220Ω resistor will limit the switch current to approximately 400mA.

V_{IN} (Pin 2): Input supply voltage.

SW1 (Pin 3): Collector of power transistor. For step-up mode connect to inductor/diode. For step-down mode connect to V_{IN} .

SW2 (Pin 4): Emitter of power transistor. For step-up mode connect to ground. For step-down mode connect to inductor/diode. This pin must never be allowed to go more than a Schottky diode drop below ground.

GND (Pin 5): Ground.

AO (Pin 6): Auxiliary Gain Block (GB) output. Open collector, can sink $300\mu A$.

SET (Pin 7): GB input. GB is an op amp with positive input connected to SET pin and negative input connected to 220mV reference.

FB/SENSE (Pin 8): On the LT1110 (adjustable) this pin goes to the comparator input. On the LT1110-5 and LT1110-12, this pin goes to the internal application resistor that sets output voltage.

LT1110 BLOCK DIAGRAM

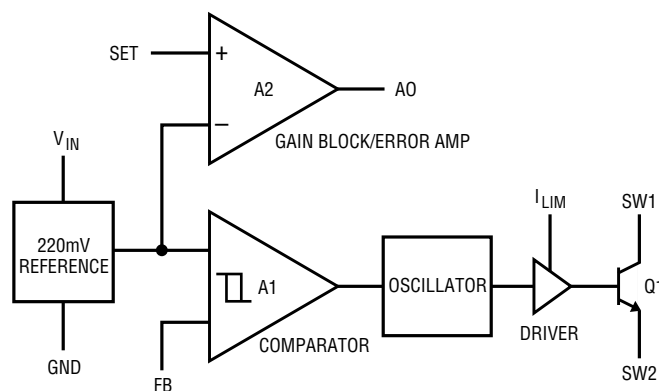

LT1110 • BD01

LT1110 OPERATION

The LT1110 is a gated oscillator switcher. This type architecture has very low supply current because the switch is cycled only when the feedback pin voltage drops below the reference voltage. Circuit operation can best be understood by referring to the LT1110 block diagram above. Comparator A1 compares the FB pin voltage with the 220mV reference signal. When FB drops below 220mV, A1 switches on the 70kHz oscillator. The driver amplifier boosts the signal level to drive the output NPN power switch Q1. An adaptive base drive circuit senses switch current and provides just enough base drive to ensure switch saturation without overdriving the switch, resulting in higher efficiency. The switch cycling action raises the output voltage and FB pin voltage. When the FB voltage is sufficient to trip A1, the oscillator is gated off. A small amount of hysteresis built into A1 ensures loop stability without external frequency compensation. When the comparator is low the oscillator and all high current circuitry is turned off, lowering device quiescent current to just 300µA for the reference, A1 and A2.

The oscillator is set internally for 10µs ON time and 5µs OFF time, optimizing the device for step-up circuits where $V_{OUT} \approx 3V_{IN}$, e.g., 1.5V to 5V. Other step-up ratios as well as step-down (buck) converters are possible at slight losses in maximum achievable power output.

A2 is a versatile gain block that can serve as a low battery detector, a linear post regulator, or drive an under voltage lockout circuit. The negative input of A2 is internally connected to the 220mV reference. An external resistor divider from V_{IN} to GND provides the trip point for A2. The AO output can sink 300µA (use a 47k resistor pull up to +5V). This line can signal a microcontroller that the battery voltage has dropped below the preset level. To prevent the gain block from operating in its linear region, a 2MΩ resistor can be connected from AO to SET. This provides positive feedback.

A resistor connected between the I_{LIM} pin and V_{IN} adjusts maximum switch current. When the switch current exceeds the set value, the switch is turned off. This feature is especially useful when small inductance values are used with high input voltages. If the internal current limit of 1.5A is desired, I_{LIM} should be tied directly to V_{IN} . Propagation delay through the current limit circuitry is about 700ns.

In step-up mode, SW2 is connected to ground and SW1 drives the inductor. In step-down mode, SW1 is connected to V_{IN} and SW2 drives the inductor. Output voltage is set by the following equation in either step-up or step-down modes where R1 is connected from FB to GND and R2 is connected from V_{OUT} to FB.

$$V_{OUT} = (220mV) \left(\frac{R2}{R1} + 1 \right). \tag{01}$$

LT1110-5, -12 BLOCK DIAGRAM

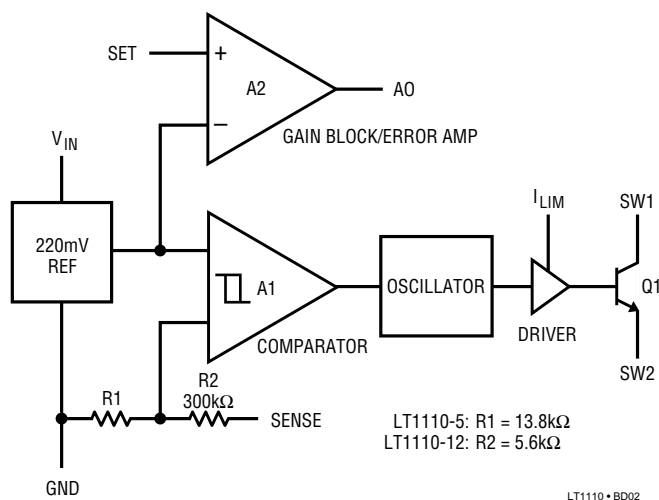

LT1110-5, -12 OPERATION

The LT1110-5 and LT1110-12 fixed output voltage versions have the gain setting resistors on-chip. Only three external components are required to construct a 5V or 12V output converter. 16µA flows through R1 and R2 in the LT1110-5, and 39µA flows in the LT1110-12. This current represents a load and the converter must cycle from time to time to maintain the proper output voltage. Output ripple, inherently present in gated oscillator designs, will typically run around 90mV for the LT1110-5 and 200mV for the LT1110-12 with the proper inductor/capacitor selection. This output ripple can be reduced considerably by using the gain block amp as a pre-amplifier in front of the FB pin. See the Applications section for details.

APPLICATIONS INFORMATION

Inductor Selection — General

A DC-DC converter operates by storing energy as magnetic flux in an inductor core, and then switching this energy into the load. Since it is flux, not charge, that is stored, the output voltage can be higher, lower, or opposite in polarity to the input voltage by choosing an appropriate switching topology. To operate as an efficient energy transfer element, the inductor must fulfill three requirements. First, the inductance must be low enough for the inductor to store adequate energy under the worst case condition of minimum input voltage and switch ON time. The inductance must also be high enough so maximum current ratings of the LT1110 and inductor are not exceeded at the other worst case condition of maximum input voltage and ON time. Additionally, the inductor core must be able to store the required flux; i.e., it must not *saturate*. At power levels generally encountered with LT1110 based designs, small surface mount ferrite core units with saturation current ratings in the 300mA to 1A range and DCR less than 0.4Ω (depending on application) are adequate. Lastly, the inductor must have sufficiently low DC resistance so excessive power is not lost as heat in the windings. An additional consideration is Electro-Magnetic Interference (EMI). Toroid and pot core type inductors are recommended in applications where EMI must be kept to a minimum; for example, where there are sensitive analog circuitry or transducers nearby. Rod core types are a less expensive choice where EMI is not a problem. Minimum and maximum input voltage, output voltage and output current must be established before an inductor can be selected.

Inductor Selection — Step-Up Converter

In a step-up, or boost converter (Figure 4), power generated by the inductor makes up the difference between input and output. Power required from the inductor is determined by

$$P_L = (V_{OUT} + V_D - V_{IN\ MIN})(I_{OUT}) \quad (01)$$

where V_D is the diode drop (0.5V for a 1N5818 Schottky).

Energy required by the inductor per cycle must be equal or greater than

$$\frac{P_L}{f_{OSC}} \quad (02)$$

in order for the converter to regulate the output.

When the switch is closed, current in the inductor builds according to

$$I_L(t) = \frac{V_{IN}}{R'} \left(1 - e^{-\frac{R't}{L}} \right) \quad (03)$$

where R' is the sum of the switch equivalent resistance (0.8Ω typical at 25°C) and the inductor DC resistance. When the drop across the switch is small compared to V_{IN} , the simple lossless equation

$$I_L(t) = \frac{V_{IN}}{L} t \quad (04)$$

can be used. These equations assume that at $t = 0$, inductor current is zero. This situation is called “discontinuous mode operation” in switching regulator parlance. Setting “ t ” to the switch ON time from the LT1110 specification table (typically $10\mu\text{s}$) will yield I_{PEAK} for a specific “ L ” and V_{IN} . Once I_{PEAK} is known, energy in the inductor at the end of the switch ON time can be calculated as

$$E_L = \frac{1}{2} L I_{PEAK}^2 \quad (05)$$

E_L must be greater than P_L/f_{OSC} for the converter to deliver the required power. For best efficiency I_{PEAK} should be kept to 1A or less. Higher switch currents will cause excessive drop across the switch resulting in reduced efficiency. In general, switch current should be held to as low a value as possible in order to keep switch, diode and inductor losses at a minimum.

As an example, suppose 12V at 120mA is to be generated from a 4.5V to 8V input. Recalling equation (01),

$$P_L = (12V + 0.5V - 4.5V)(120mA) = 960mW. \quad (06)$$

Energy required from the inductor is

$$\frac{P_L}{f_{OSC}} = \frac{960mW}{70kHz} = 13.7\mu\text{J}. \quad (07)$$

APPLICATIONS INFORMATION

Picking an inductor value of 47μH with 0.2Ω DCR results in a peak switch current of

$$I_{PEAK} = \frac{4.5V}{1.0W} \left[1 - e^{-\frac{1.0W \cdot 10ms}{47mH}} \right] = 862mA. \quad (08)$$

Substituting I_{PEAK} into Equation 05 results in

$$E_L = \frac{1}{2} (47\mu H) (0.862A)^2 = 17.5\mu J. \quad (09)$$

Since 17.5μJ > 13.7μJ, the 47μH inductor will work. This trial-and-error approach can be used to select the optimum inductor. Keep in mind the switch current maximum rating of 1.5A. If the calculated peak current exceeds this, an external power transistor can be used.

A resistor can be added in series with the I_{LIM} pin to invoke switch current limit. The resistor should be picked such that the calculated I_{PEAK} at minimum V_{IN} is equal to the Maximum Switch Current (from Typical Performance Characteristic curves). Then, as V_{IN} increases, switch current is held constant, resulting in increasing efficiency.

Inductor Selection — Step-Down Converter

The step-down case (Figure 5) differs from the step-up in that the inductor current flows through the load during both the charge and discharge periods of the inductor. Current through the switch should be limited to ~800mA in this mode. Higher current can be obtained by using an external switch (see Figure 6). The I_{LIM} pin is the key to successful operation over varying inputs.

After establishing output voltage, output current and input voltage range, peak switch current can be calculated by the formula

$$I_{PEAK} = \frac{2I_{OUT}}{DC} \left[\frac{V_{OUT} + V_D}{V_{IN} - V_{SW} + V_D} \right] \quad (10)$$

where DC = duty cycle (0.69)

V_{SW} = switch drop in step-down mode

V_D = diode drop (0.5V for a 1N5818)

I_{OUT} = output current

V_{OUT} = output voltage

V_{IN} = minimum input voltage

V_{SW} is actually a function of switch current which is in turn a function of V_{IN} , L, time and V_{OUT} . To simplify, 1.5V can be used for V_{SW} as a very conservative value.

Once I_{PEAK} is known, inductor value can be derived from

$$L = \frac{V_{IN\ MIN} - V_{SW} - V_{OUT}}{I_{PEAK}} \cdot t_{ON} \quad (11)$$

where t_{ON} = switch ON time (10μs).

Next, the current limit resistor R_{LIM} is selected to give I_{PEAK} from the R_{LIM} Step-Down Mode curve. The addition of this resistor keeps maximum switch current constant as the input voltage is increased.

As an example, suppose 5V at 250mA is to be generated from a 9V to 18V input. Recalling Equation (10),

$$I_{PEAK} = \frac{2(250mA)}{0.69} \left[\frac{5 + 0.5}{9 - 1.5 + 0.5} \right] = 498mA. \quad (12)$$

Next, inductor value is calculated using Equation (11)

$$L = \frac{9 - 1.5 - 5}{498mA} \cdot 10\mu s = 50\mu H. \quad (13)$$

Use the next lowest standard value (47μH).

Then pick R_{LIM} from the curve. For $I_{PEAK} = 500mA$, $R_{LIM} = 82\Omega$.

Inductor Selection — Positive-to-Negative Converter

Figure 7 shows hookup for positive-to-negative conversion. All of the output power must come from the inductor. In this case,

$$P_L = (|V_{OUT}| + V_D)(I_{OUT}). \quad (14)$$

In this mode the switch is arranged in common collector or step-down mode. The switch drop can be modeled as a 0.75V source in series with a 0.65Ω resistor. When the

APPLICATIONS INFORMATION

switch closes, current in the inductor builds according to

$$I_L (+) = \frac{V_L}{R'} \left(1 - e^{-\frac{R't}{L}} \right) \quad (15)$$

where $R' = 0.65\Omega + DCR_L$
 $V_L = V_{IN} - 0.75V$

As an example, suppose $-5V$ at $75mA$ is to be generated from a $4.5V$ to $5.5V$ input. Recalling Equation (14),

$$P_L = (|-5V| + 0.5V) (75mA) = 413mW. \quad (16)$$

Energy required from the inductor is

$$\frac{P_L}{f_{OSC}} = \frac{413mW}{70kHz} = 5.9\mu J. \quad (17)$$

Picking an inductor value of $56\mu H$ with 0.2Ω DCR results in a peak switch current of

$$I_{PEAK} = \frac{(4.5V - 0.75V)}{(0.65\Omega + 0.2\Omega)} \left(1 - e^{-\frac{0.85\Omega \cdot 10\mu s}{56\mu H}} \right) = 621mA. \quad (18)$$

Substituting I_{PEAK} into Equation (04) results in

$$E_L = \frac{1}{2} (56\mu H) (0.621A)^2 = 10.8\mu J. \quad (19)$$

Since $10.8\mu J > 5.9\mu J$, the $56\mu H$ inductor will work.

With this relatively small input range, R_{LIM} is not usually necessary and the I_{LIM} pin can be tied directly to V_{IN} . As in the step-down case, peak switch current should be limited to $\sim 800mA$.

Capacitor Selection

Selecting the right output capacitor is almost as important as selecting the right inductor. A poor choice for a filter capacitor can result in poor efficiency and/or high output ripple. Ordinary aluminum electrolytics, while inexpensive and readily available, may have unacceptably poor Equivalent Series Resistance (ESR) and ESL (inductance). There are low ESR aluminum capacitors on the market specifically designed for switch mode DC-DC converters which work much better than general-purpose units. Tantalum

capacitors provide still better performance at more expense. We recommend OS-CON capacitors from Sanyo Corporation (San Diego, CA). These units are physically quite small and have extremely low ESR. To illustrate, Figures 1, 2 and 3 show the output voltage of an LT1110 based converter with three $100\mu F$ capacitors. The peak switch current is $500mA$ in all cases. Figure 1 shows a Sprague 501D, $25V$ aluminum capacitor. V_{OUT} jumps by over $120mV$ when the switch turns off, followed by a drop in voltage as the inductor dumps into the capacitor. This works out to be an ESR of over $240m\Omega$. Figure 2 shows the same circuit, but with a Sprague 150D, $20V$ tantalum capacitor replacing the aluminum unit. Output jump is now about $35mV$, corresponding to an ESR of $70m\Omega$. Figure 3 shows the circuit with a $16V$ OS-CON unit. ESR is now only $20m\Omega$.

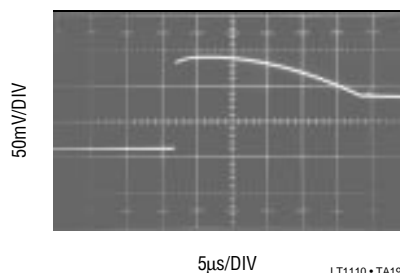

Figure 1. Aluminum

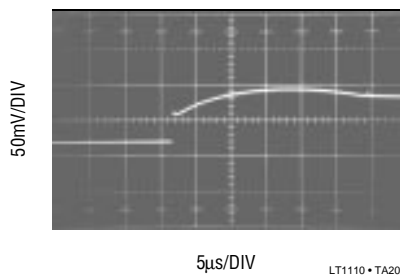

Figure 2. Tantalum

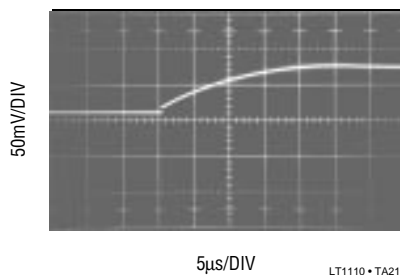

Figure 3. OS-CON

APPLICATIONS INFORMATION

Diode Selection

Speed, forward drop, and leakage current are the three main considerations in selecting a catch diode for LT1110 converters. General purpose rectifiers such as the 1N4001 are *unsuitable* for use in *any* switching regulator application. Although they are rated at 1A, the switching time of a 1N4001 is in the 10µs-50µs range. At best, efficiency will be severely compromised when these diodes are used; at worst, the circuit may not work at all. Most LT1110 circuits will be well served by a 1N5818 Schottky diode, or its surface mount equivalent, the MBR5130T3. The combination of 500mV forward drop at 1A current, fast turn ON and turn OFF time, and 4µA to 10µA leakage current fit nicely with LT1110 requirements. At peak switch currents of 100mA or less, a 1N4148 signal diode may be used. This diode has leakage current in the 1nA-5nA range at 25°C and lower cost than a 1N5818. (You can also use them to get your circuit up and running, but beware of destroying the diode at 1A switch currents.)

Step-Up (Boost Mode) Operation

A step-up DC-DC converter delivers an output voltage higher than the input voltage. Step-up converters are *not* short circuit protected since there is a DC path from input to output.

The usual step-up configuration for the LT1110 is shown in Figure 4. The LT1110 first pulls SW1 low causing $V_{IN} - V_{CESAT}$ to appear across L1. A current then builds up in L1. At the end of the switch ON time the current in L1 is¹:

$$I_{PEAK} = \frac{V_{IN}}{L} t_{ON} \quad (20)$$

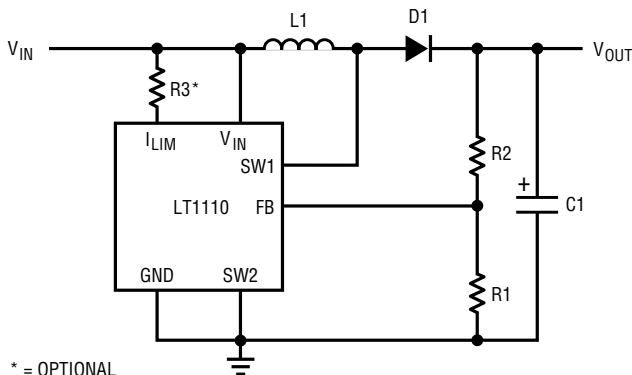

Figure 4. Step-Up Mode Hookup.

Immediately after switch turn off, the SW1 voltage pin starts to rise because current cannot instantaneously stop flowing in L1. When the voltage reaches $V_{OUT} + V_D$, the inductor current flows through D1 into C1, increasing V_{OUT} . This action is repeated as needed by the LT1110 to keep V_{FB} at the internal reference voltage of 220mV. R1 and R2 set the output voltage according to the formula

$$V_{OUT} = \left(1 + \frac{R2}{R1}\right) (220mV). \quad (21)$$

Step-Down (Buck Mode) Operation

A step-down DC-DC converter converts a higher voltage to a lower voltage. The usual hookup for an LT1110 based step-down converter is shown in Figure 5.

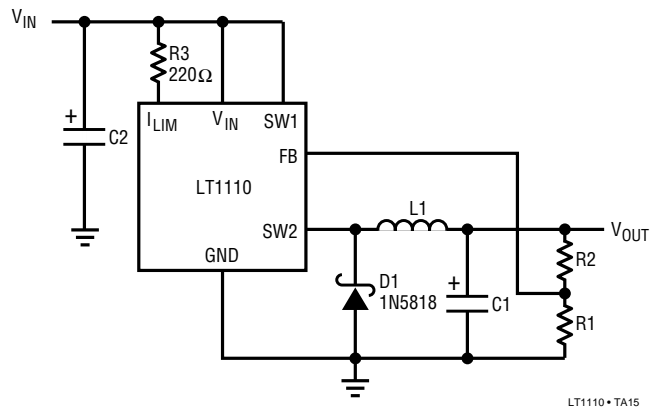

Figure 5. Step-Down Mode Hookup

When the switch turns on, SW2 pulls up to $V_{IN} - V_{SW}$. This puts a voltage across L1 equal to $V_{IN} - V_{SW} - V_{OUT}$, causing a current to build up in L1. At the end of the switch ON time, the current in L1 is equal to

$$I_{PEAK} = \frac{V_{IN} - V_{SW} - V_{OUT}}{L} t_{ON}. \quad (22)$$

When the switch turns off, the SW2 pin falls rapidly and actually goes below ground. D1 turns on when SW2 reaches 0.4V below ground. **D1 MUST BE A SCHOTTKY DIODE.** The voltage at SW2 must never be allowed to go below -0.5V. A silicon diode such as the 1N4933 will allow SW2 to go to -0.8V, causing potentially destructive power

Note 1: This simple expression neglects the effects of switch and coil resistance. This is taken into account in the "Inductor Selection" section.

APPLICATIONS INFORMATION

dissipation inside the LT1110. Output voltage is determined by

$$V_{OUT} = \left(1 + \frac{R_2}{R_1}\right) (220\text{mV}). \quad (23)$$

R3 programs switch current limit. This is especially important in applications where the input varies over a wide range. Without R3, the switch stays on for a fixed time each cycle. Under certain conditions the current in L1 can build up to excessive levels, exceeding the switch rating and/or saturating the inductor. The 220Ω resistor programs the switch to turn off when the current reaches approximately 800mA. When using the LT1110 in step-down mode, output voltage should be limited to 6.2V or less. Higher output voltages can be accommodated by inserting a 1N5818 diode in series with the SW2 pin (anode connected to SW2).

Higher Current Step-Down Operation

Output current can be increased by using a discrete PNP pass transistor as shown in Figure 6. R1 serves as a current limit sense. When the voltage drop across R1 equals a V_{BE} , the switch turns off. For temperature compensation a Schottky diode can be inserted in series with the I_{LIM} pin. This also lowers the maximum drop across R1 to $V_{BE} - V_D$, increasing efficiency. As shown, switch current is limited to 2A. Inductor value can be calculated based on formulas in the “Inductor Selection Step-Down

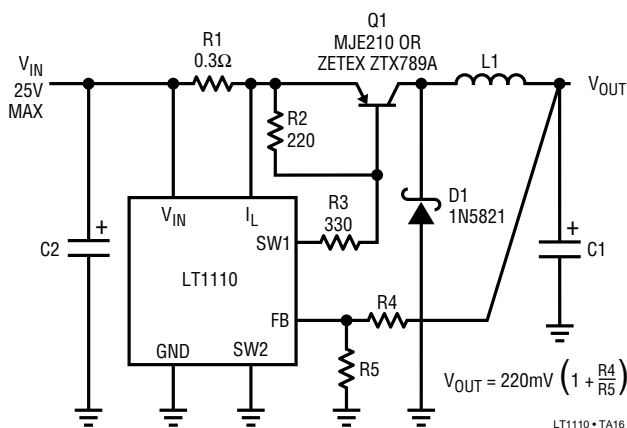

Figure 6. Q1 Permits Higher-Current Switching. LT1110 Functions as Controller.

Converter” section with the following conservative expression for V_{SW} :

$$V_{SW} = V_{R1} + V_{SAT} \approx 0.9V. \quad (24)$$

R2 provides a current path to turn off Q1. R3 provides base drive to Q1. R4 and R5 set output voltage.

Inverting Configurations

The LT1110 can be configured as a positive-to-negative converter (Figure 7), or a negative-to-positive converter (Figure 8). In Figure 7, the arrangement is very similar to a step-down, except that the high side of the feedback is referred to ground. This level shifts the output negative. As in the step-down mode, D1 must be a Schottky diode, and $|V_{OUT}|$ should be less than 6.2V. More negative output voltages can be accommodated as in the prior section.

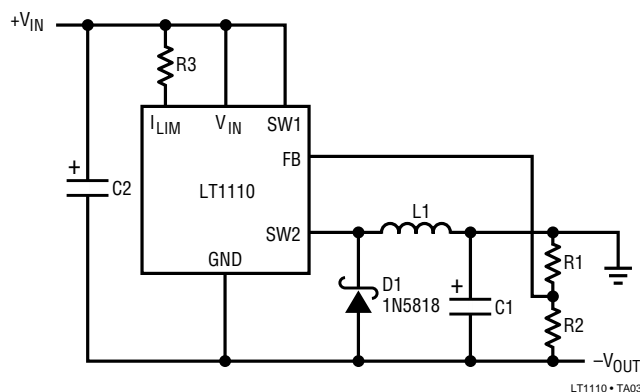

Figure 7. Positive-to-Negative Converter

In Figure 8, the input is negative while the output is positive. In this configuration, the magnitude of the input voltage can be higher or lower than the output voltage. A level shift, provided by the PNP transistor, supplies proper polarity feedback information to the regulator.

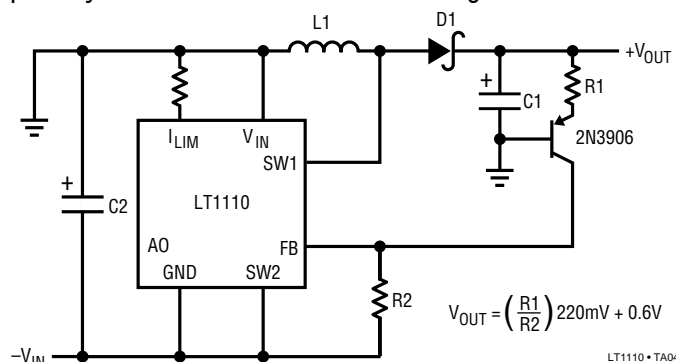

Figure 8. Negative-to-Positive Converter

APPLICATIONS INFORMATION

Using the I_{LIM} Pin

The LT1110 switch can be programmed to turn off at a set switch current, a feature not found on competing devices. This enables the input to vary over a wide range without exceeding the maximum switch rating or saturating the inductor. Consider the case where analysis shows the LT1110 must operate at an 800mA peak switch current with a 2.0V input. If V_{IN} rises to 4V, peak current will rise to 1.6A, exceeding the maximum switch current rating. With the proper resistor selected (see the “Maximum Switch Current vs R_{LIM} ” characteristic), the switch current will be limited to 800mA, even if the input voltage increases.

Another situation where the I_{LIM} feature is useful occurs when the device goes into continuous mode operation. This occurs in step-up mode when

$$\frac{V_{OUT} + V_{DIODE}}{V_{IN} - V_{SW}} < \frac{1}{1 - DC} \quad (25)$$

When the input and output voltages satisfy this relationship, inductor current does not go to zero during the switch OFF time. When the switch turns on again, the current ramp starts from the non-zero current level in the inductor just prior to switch turn on. As shown in Figure 9, the inductor current increases to a high level before the comparator turns off the oscillator. This high current can cause excessive output ripple and requires oversizing the output capacitor and inductor. With the I_{LIM} feature, however, the switch current turns off at a programmed level as shown in Figure 10, keeping output ripple to a minimum.

Figure 11 details current limit circuitry. Sense transistor Q1, whose base and emitter are paralleled with power switch Q2, is ratioed such that approximately 0.5% of Q2’s collector current flows in Q1’s collector. This current is passed through internal 80Ω resistor R1 and out through the I_{LIM} pin. The value of the external resistor connected between I_{LIM} and V_{IN} set the current limit. When sufficient switch current flows to develop a V_{BE} across $R1 + R_{LIM}$, Q3 turns on and injects current into the oscillator, turning off the switch. Delay through this circuitry is approximately 800ns. The current trip point becomes less accurate for

switch ON times less than 3μs. Resistor values programming switch ON time for 800ns or less will cause spurious response in the switch circuitry although the device will still maintain output regulation.

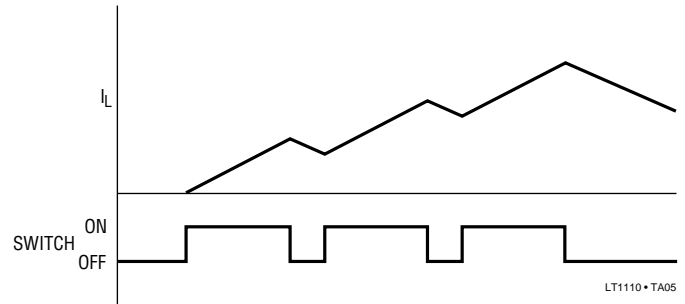

Figure 9. No Current Limit Causes Large Inductor Current Build-Up

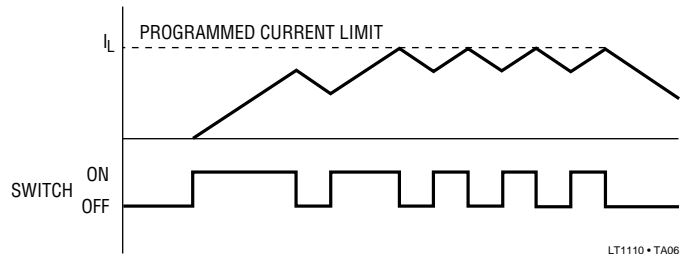

Figure 10. Current Limit Keeps Inductor Current Under Control

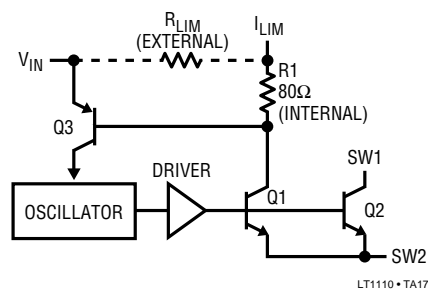

Figure 11. LT1110 Current Limit Circuitry

Using the Gain Block

The gain block (GB) on the LT1110 can be used as an error amplifier, low battery detector or linear post regulator. The gain block itself is a very simple PNP input op amp with an open collector NPN output. The negative input of the gain block is tied internally to the 220mV reference. The positive input comes out on the SET pin.

APPLICATIONS INFORMATION

Arrangement of the gain block as a low battery detector is straightforward. Figure 12 shows hookup. R1 and R2 need only be low enough in value so that the bias current of the SET input does not cause large errors. 33kΩ for R2 is adequate. R3 can be added to introduce a small amount of hysteresis. This will cause the gain block to “snap” when the trip point is reached. Values in the 1M-10M range are optimal. The addition of R3 will change the trip point, however.

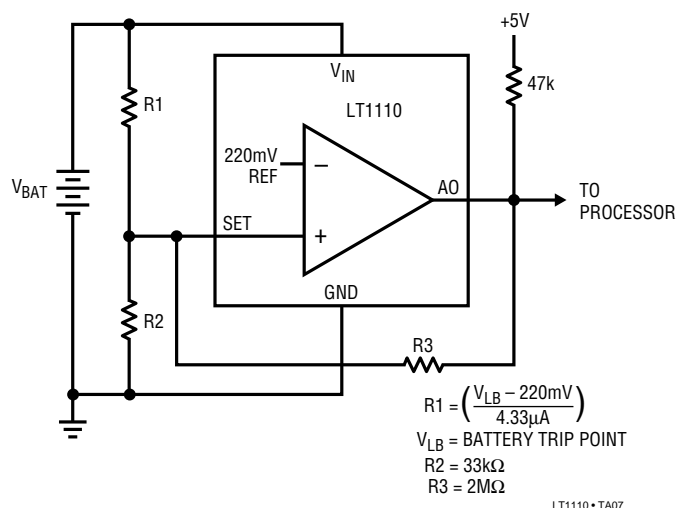

Figure 12. Setting Low Battery Detector Trip Point

Output ripple of the LT1110, normally 90mV at 5V_{OUT} can be reduced significantly by placing the gain block in front of the FB input as shown in Figure 13. This effectively reduces the comparator hysteresis by the gain of the gain block. Output ripple can be reduced to just a few millivolts using this technique. Ripple reduction works with step-down or inverting modes as well. For this technique to be effective, output capacitor C1 must be large, so that each switching cycle increases V_{OUT} by only a few millivolts. 1000μF is a good starting value.

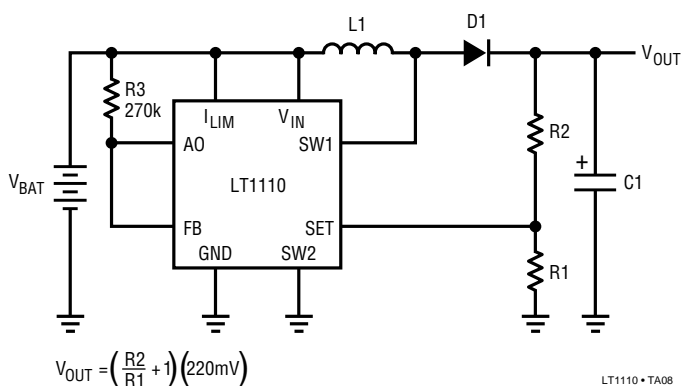

Figure 13. Output Ripple Reduction Using Gain Block

Table 1. Inductor Manufacturers

MANUFACTURER	PART NUMBERS
Coiltronics International 984 S.W. 13th Court Pompano Beach, FL 33069 305-781-8900	CTX100-4 Series Surface Mount
Sumida Electric Co. USA 708-956-0666	CD54 CDR74 CDR105 Surface Mount

Table 2. Capacitor Manufacturers

MANUFACTURER	PART NUMBERS
Sanyo Video Components 2001 Sanyo Avenue San Diego, CA 92173 619-661-6835	OS-CON Series
Nichicon America Corporation 927 East State Parkway Schaumburg, IL 60173 708-843-7500	PL Series
Sprague Electric Company Lower Main Street Sanford, ME 04073 207-324-4140	150D Solid Tantalums 550D Tantalex
Matsuo 714-969-2491	267 Series Surface Mount

Table 3. Transistor Manufacturers

MANUFACTURER	PART NUMBERS
Zetex Commack, NY 516-543-7100	ZTX Series FZT Series Surface Mount

TYPICAL APPLICATIONS

**All Surface Mount
Flash Memory V_{PP} Generator**

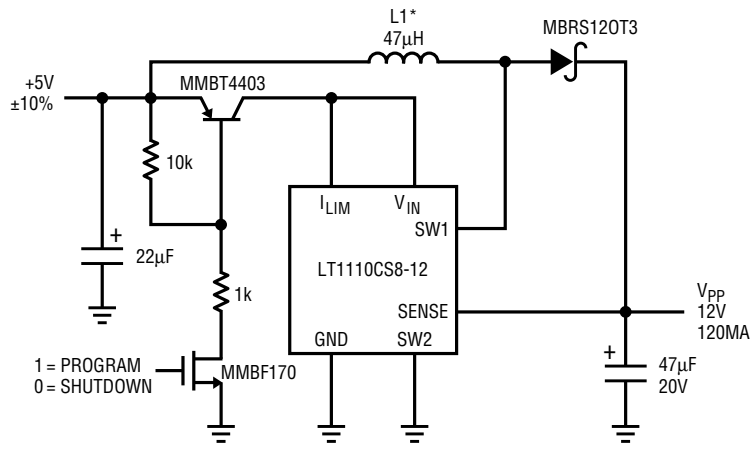

*L1= SUMIDA CD105-470M

LT1110 • TA18

1.5V Powered Laser Diode Driver

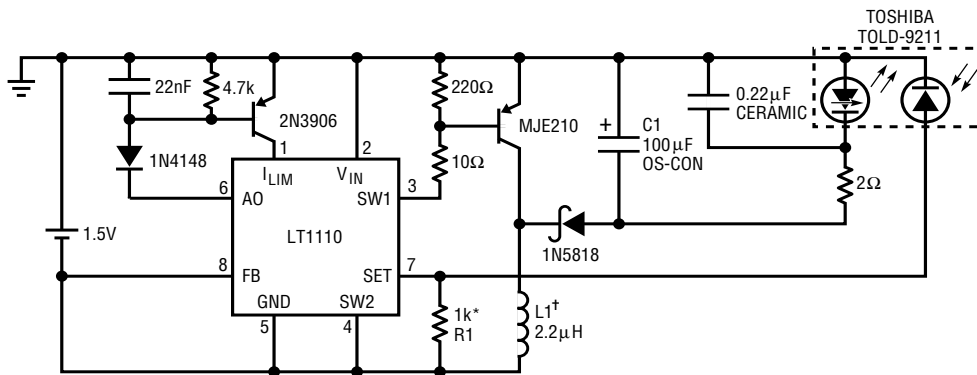

- * ADJUST R1 FOR CHANGE IN LASER OUTPUT POWER
- † TOKO 262LYF-0076M
- LASER DIODE CASE COMMON TO +BATTERY TERMINAL
- 170mA CURRENT DRAIN FROM 1.5V CELL (50mA DIODE)
- NO OVERSHOOT

LT1110 • TA13

1.5V Powered Laser Diode Driver

TYPICAL APPLICATIONS

**All Surface Mount
3V to 5V Step-Up Converter**

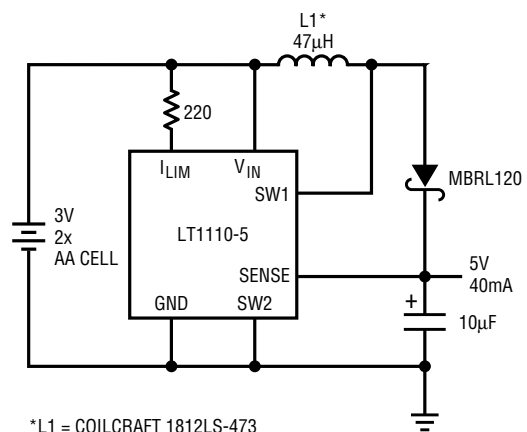

*L1 = COILCRAFT 1812LS-473

LT1110 • TA09

**All Surface Mount
9V to 5V Step-Down Converter**

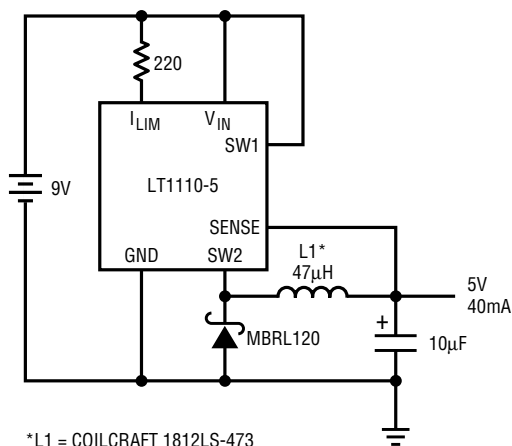

*L1 = COILCRAFT 1812LS-473

LT1110 • TA10

**All Surface Mount
1.5V to +10V, +5V Dual Output Step-Up Converter**

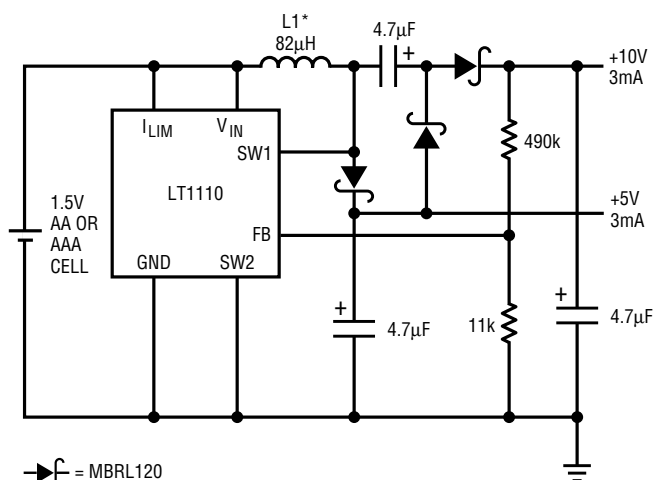

→f = MBRL120

*L1 = COILCRAFT 1812LS-823

LT1110 • TA11

**All Surface Mount
1.5V to ±5V Dual Output Step-Up Converter**

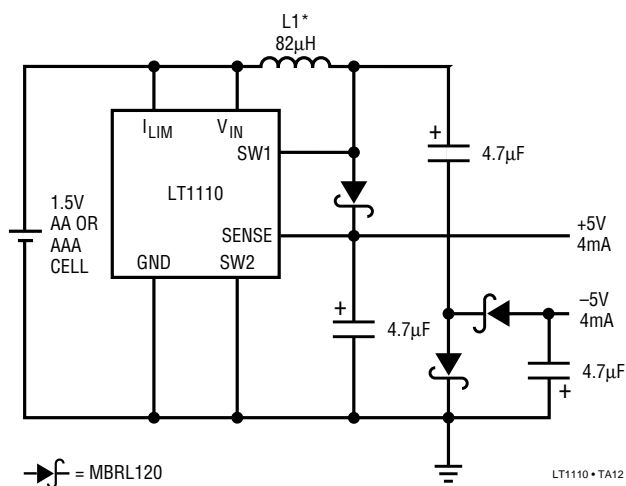

→f = MBRL120

*L1 = COILCRAFT 1812LS-823

LT1110 • TA12

PACKAGE DESCRIPTION Dimensions in inches (millimeters) unless otherwise noted.

**N8 Package
8-Lead Plastic DIP**

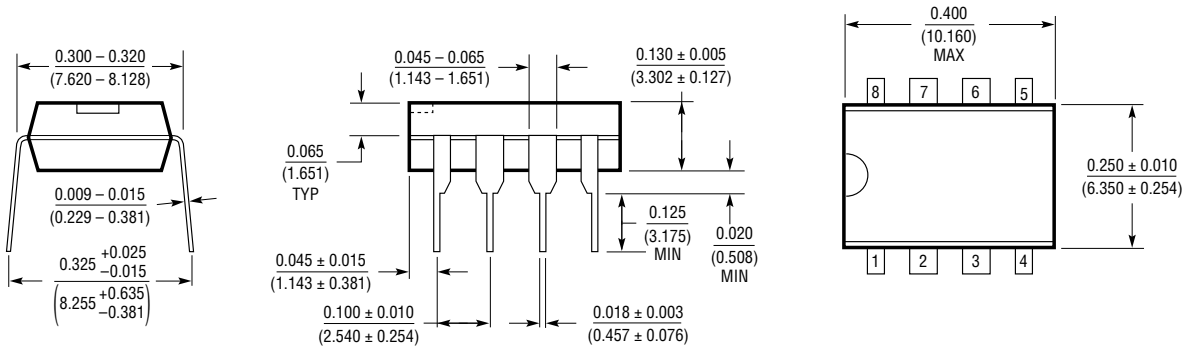

**S8 Package
8-Lead Plastic SOIC**

