

LTC4269-1 PoE+ (802.3at) Powered Device Controller and Synchronous Flyback

DESCRIPTION

Demonstration circuit 1335B-B is a high-power supply featuring the LTC®4269-1. This board acts as an IEEE 802.3at compliant, high power Power-over-Ethernet (PoE), Powered Device (PD) and connects at the RJ45 to a compatible high power Power Sourcing Equipment (PSE) device, such as the DC1366.

The LTC4269-1 provides IEEE 802.3at standard (PoE+) PD interfacing and power supply control. When the PD is fully powered, the PD interface switches power over from the PSE to the switcher through an internal, low resistance, high power MOSFET. The highly integrated LTC4269-1

controls a high-power, small-sized power supply that utilizes a highly efficient isolated flyback topology with synchronous rectification. The DC1335B-B supplies a 5V output at up to 4.5A.

DC1335B-B also demonstrates the use of an auxiliary 48V wall adapter. When present, the auxiliary supply becomes the dominant supply over PoE to provide power.

Design files for this circuit board are available at <http://www.linear.com/demo>

LT, LT, LTC, LTM, µModule, Linear Technology and the Linear logo are registered trademarks of Linear Technology Corporation. All other trademarks are the property of their respective owners.

PERFORMANCE SUMMARY (T_A = 25°C)

PARAMETER	CONDITIONS	VALUE
Port Voltage (V _{PORT})	At Ethernet Port	37V to 57V
Auxiliary Voltage (V _{AUX})	From AUX ⁻ to AUX ⁺ Terminals	44V to 57V
Output Voltage (V _{OUT}) Initial Set-point	V _{PORT} = 37V to 57V, I _{OUT} = 0A to 5A	5V ±1%
Maximum Output Current	V _{PORT} = 42V	4.5A
Typical Output Voltage Ripple	V _{IN} = 50V, I _{OUT} = 4.6A	40mV _{P-P} (Typ)
Output Regulation	Over Entire Input Voltage and Output Current Range	±0.4% (Typ)
Load Transient Response	Peak to Peak Deviation with Load Step of 2.5A to 5A	±240mV (<±5%) (Typ)
	Settling Time (within 1% of V _{OUT})	<100µs (Typ)
Switching Frequency		250kHz (Typ)
Efficiency	V _{PORT} = 50V, I _{OUT} = 4A, Not Including Diode Bridge	91% (Typ)

OPERATING PRINCIPLES

A compatible high power PSE board, such as the DC1366, is connected to the DC1335B-B at the RJ45 connector J1 (see the schematic in Figure 11). As required by IEEE 802.3at, a diode bridge is used across the data pairs and signal pairs. Schottky diodes (D2-9) are used at the input to improve efficiency over standard diode bridges. The LTC4269-1 provides an IEEE 802.3at standard PoE 25k signature resistance and is set for a power class 4.

When the PD is powered and voltage is above the PoE on voltage, the LTC4269-1 switches the port voltage over to the power supply controller through its internal MOSFET which lies between the V_{PORTN} and V_{NEG} pins. This voltage charges C18/19 through a trickle charge resistor, R9 to power the bias pin, V_{CC}, of the power supply controller. Once the bias power gets to its V_{CC(ON)} threshold, the IC begins a controlled soft-start of the output. As the output

OPERATING PRINCIPLES

voltage rises, bias power is taken over by the bias supply made up of T1's bias winding and D11.

When the soft-start period is over, the output voltage is regulated by observing the pulses across the bias winding during the flyback time. The Primary Gate drive (PG) and Synchronous Gate (SG) drive is then Pulse Width Modulated (PWM) in order to keep the output voltage constant. The synchronous gate drive signal is transmitted

to the secondary via the small signal transformer, T2. The output of T2 then drives a discrete gate drive buffer, R22 and Q6/7 in order to achieve fast gate transition times, hence a higher efficiency.

The two-stage input filter, C5, L2, and C6 and output filter, C1/3, L1, and C10 are the reasons that this PoE flyback supply has exceptionally low differential mode conducted emissions.

QUICK START PROCEDURE

Demonstration circuit 1335B-B is easy to set up to evaluate the performance of the LTC4269-1 in a PoE+ PD application. Refer to Figure 1 for proper equipment setup and follow the procedure below:

NOTE: When measuring the input or output voltage ripple, care must be taken to avoid a long ground lead on the oscilloscope probe. Measure the output (or input) voltage ripple by touching the probe tip and probe ground directly across the $+V_{OUT}$ and $-V_{OUT}$ (or V_{PORT_P} and V_{PORT_N}) terminals. See Figure 2 for proper scope probe technique.

1. Place test equipment (voltmeter, ammeter, and electronic load) across output.

2. Input supplies:

- a. Connect a PoE+ capable PSE with a CAT-5 cable to the RJ45 connector, J1. See Figure 1.
- b. Or, connect a 37V to 57V capable power supply (Power Supply in Figure 1) across V_{PORT_P} and V_{PORT_N} .
- c. If evaluating the auxiliary power supply (Auxiliary Supply in Figure 1) capability, connect a 44V to 57V capable power supply across AUX^+ to AUX^- .

3. Check for the proper output voltage of 5V.

4. Once the proper output voltage is confirmed, adjust the load within the operating range and observe the output voltage regulation, ripple voltage, efficiency and other parameters.

QUICK START PROCEDURE

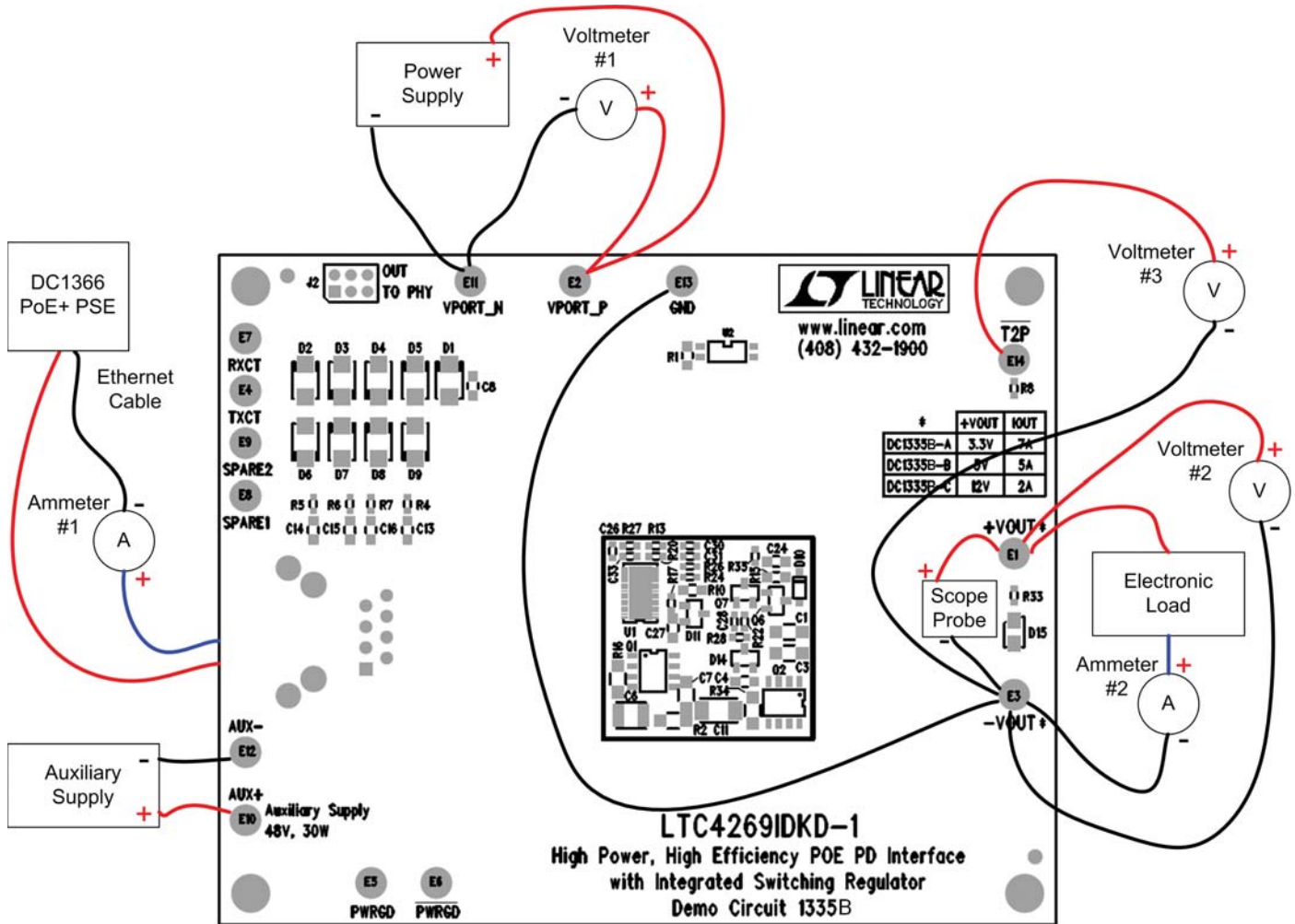

Figure 1. Proper Measurement Equipment Setup

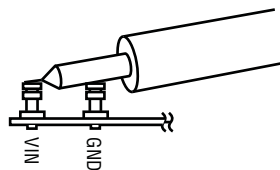

Figure 2. Measuring Input or Output Ripple

MEASURED DATA

Figures 3 through 10 are measured data for a typical DC1335B-B.

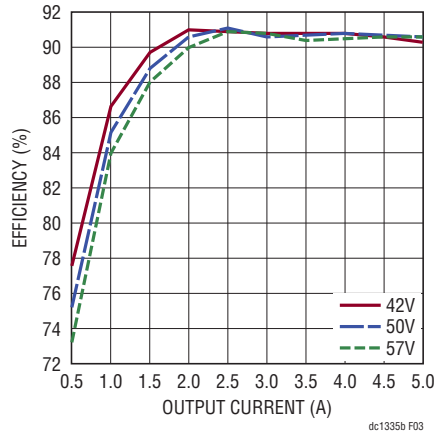

Figure 3. Efficiency (Not Including Diode Bridge)

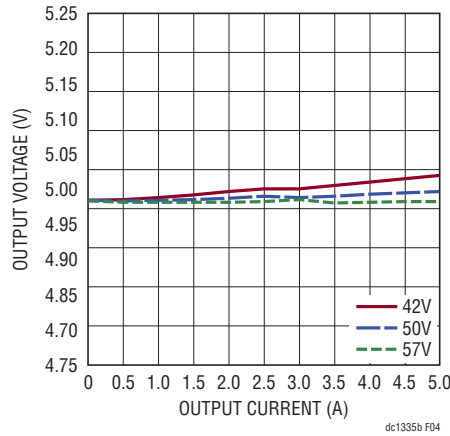

Figure 4. Regulation

MEASURED DATA

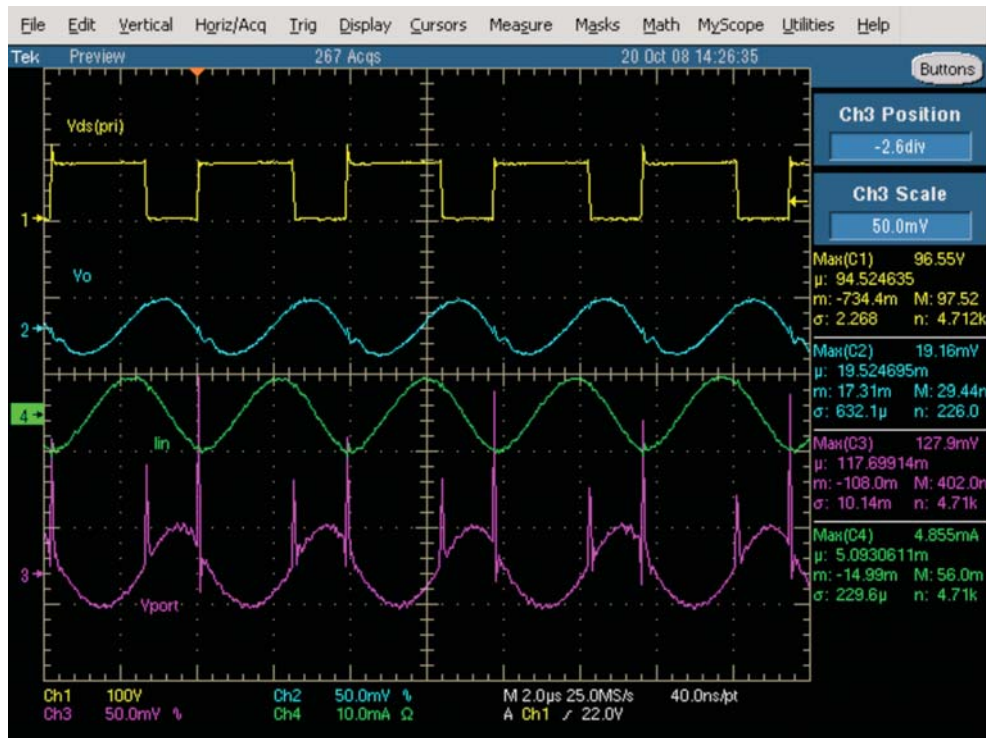

Figure 5. Input and Output Ripple (48V_{PORT}, 5A)



Figure 6. Load Transient Response (48V_{PORT}, 2.5A to 5A to 2.5A)

MEASURED DATA

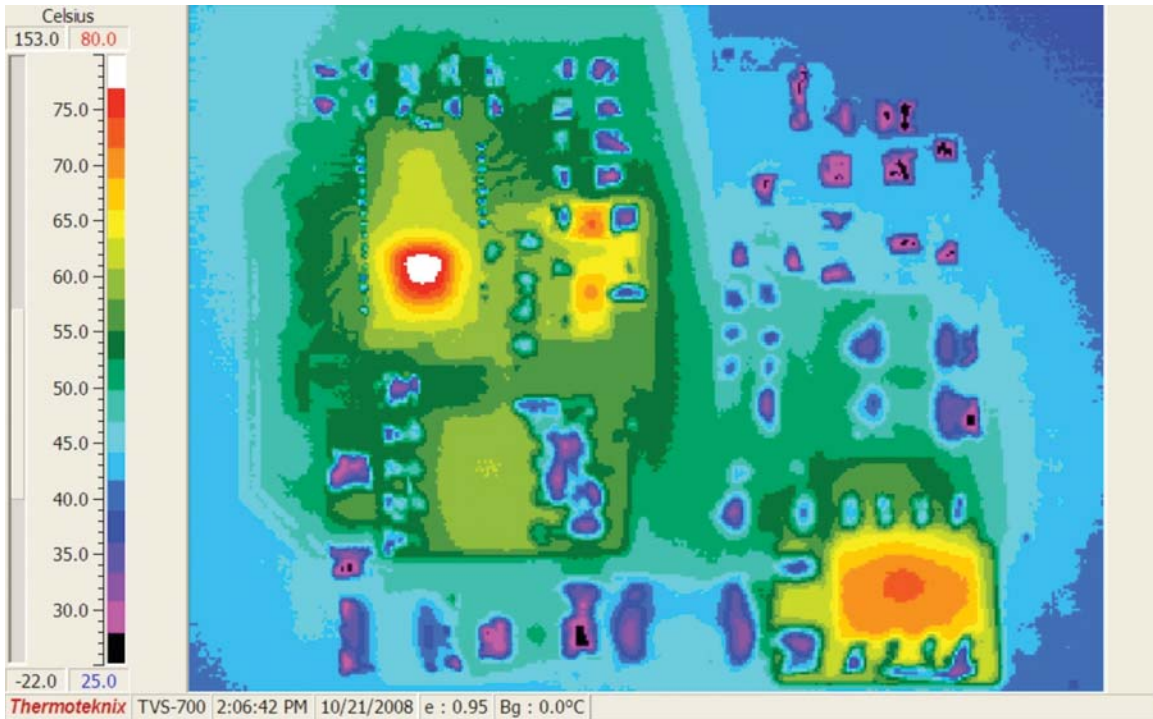

Figure 7. Temp Data (37V_{PORT}, 5A, Top)

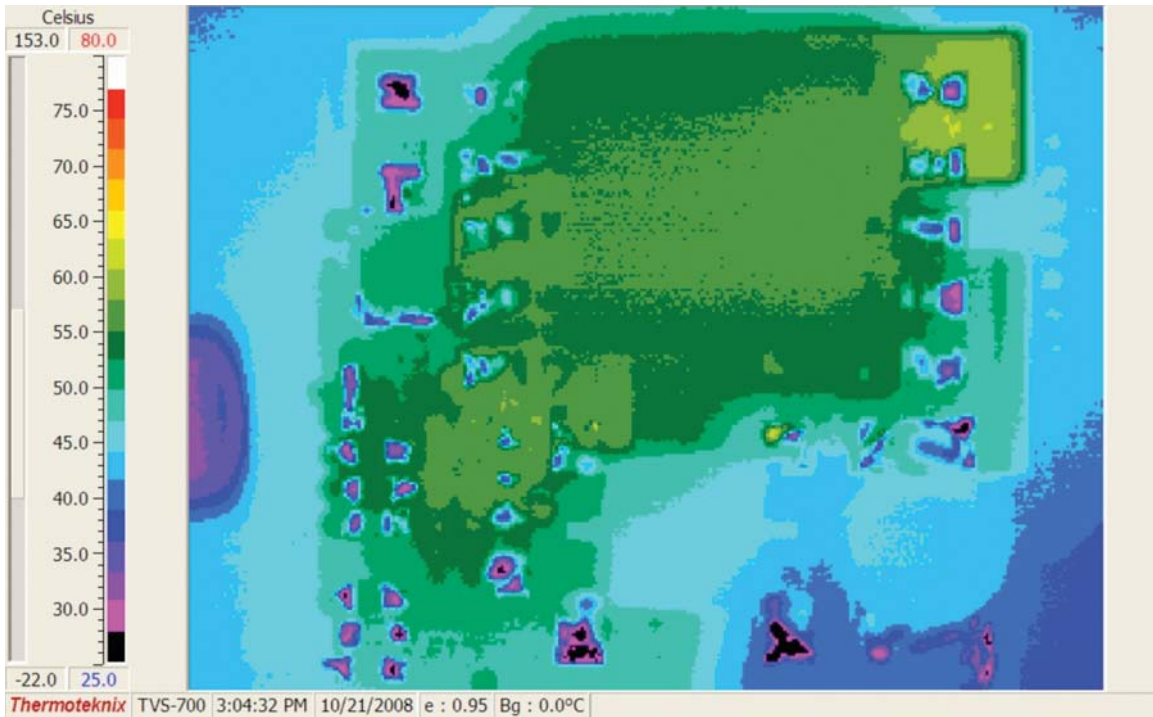

Figure 8. Temp Data (37V_{PORT}, 5A, Bottom)

MEASURED DATA

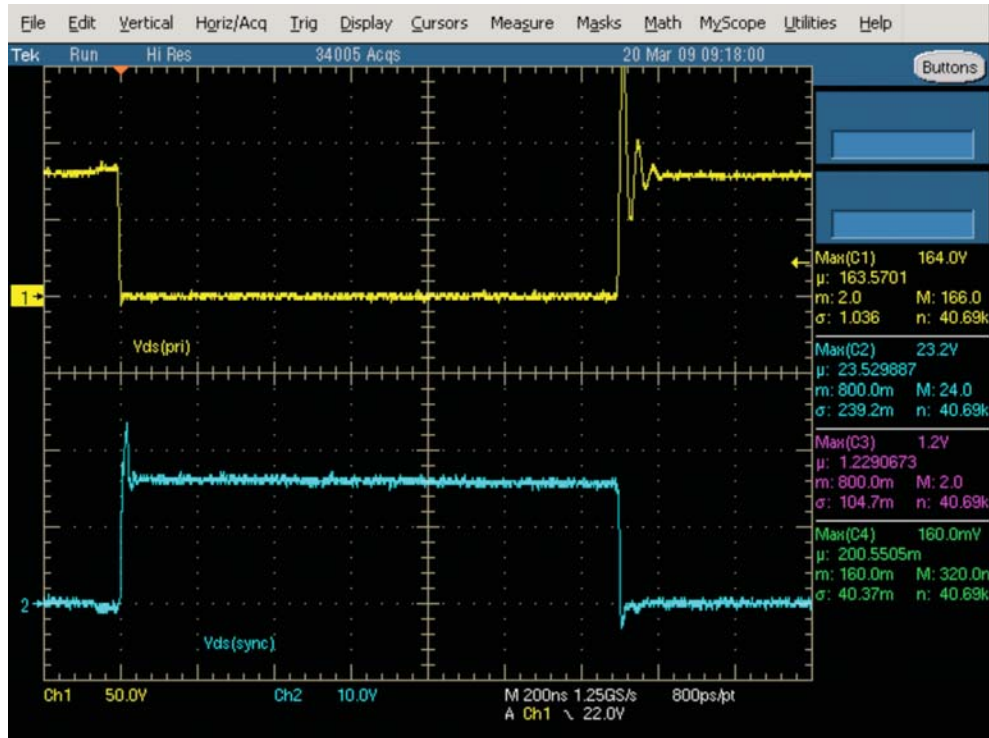

Figure 9. Stresses (57V_{PORT}, 5A)

MEASURED DATA

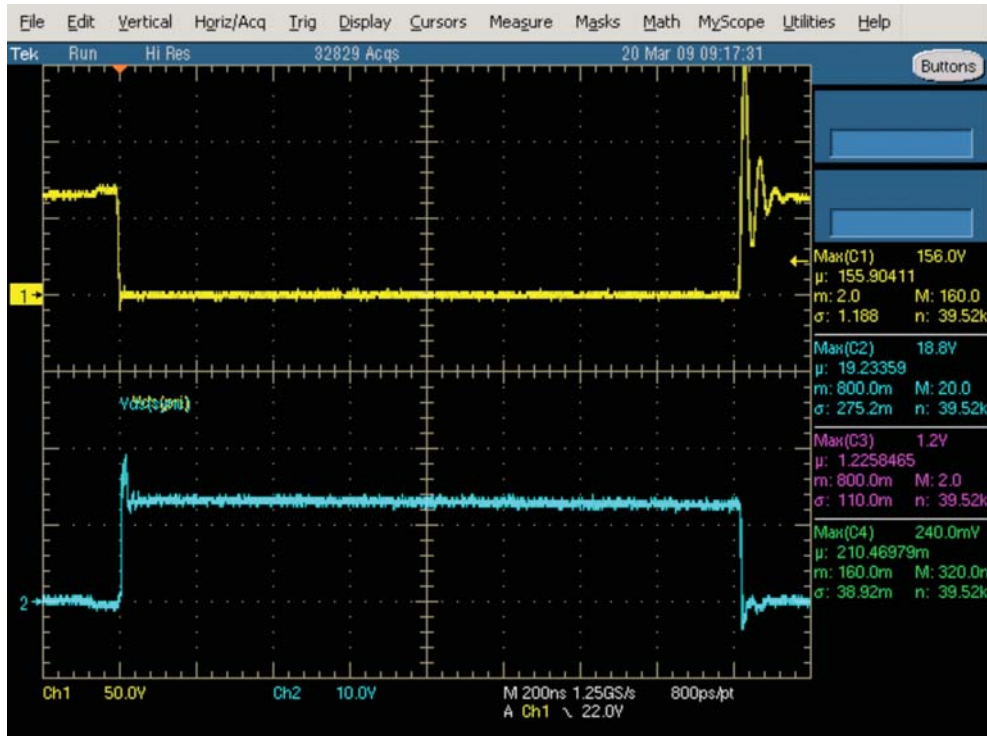

Figure 10. Stresses (37V_{PORT}, 5A)

PARTS LIST

ITEM	QTY	REFERENCE	PART DESCRIPTION	MANUFACTURER/PART NUMBER
Required Circuit Components				
1	2	C1, C3	CAP., X5R, 22 μ F, 6.3V, 1206	MURATA, GRM31CR60J226KE19
2	1	C4	CAP., X7R, 1500pF, 50V, 0805	AVX, 08055C152JAT
3	1	C7	CAP., NPO, 22pF, 200V, 1206	muRata, GRM31A7U2J220JW31D
4	1	C10	CAP., TANT, 100 μ F, 6.3V, 3528	NEO CAPACITOR, PSLB20J107M(45)
5	1	C18	CAP., TANT, 10 μ F, 16V, B2	NEO CAPACITOR, ESVB21C106M
6	1	C26	CAP., X7R, 3300pF, 50V, 0603	AVX, 06035C332JAT
7	1	C33	CAP., X7R, 1000pF, 50V, 0603	AVX, 06035C102JAT
8	1	C30	CAP., NPO, 33pF, 50V, 0603	AVX, 06035A330KAT2A
9	1	C28	CAP., X7R, 2200pF, 50V, 0603	AVX, 06035C222JAT
10	1	C11	CAP., X7R, 2200pF, 2KV, 1808	AVX, 1808GC222MAT1A
11	1	C8	CAP., X7R, 0.1 μ F, 100V, 0805	AVX, 08051C104JAT
12	1	C32	CAP., X7R, 0.1 μ F, 50V, 0603	AVX, 06035C104KAT2A
13	3	C19, C24, C27	CAP., X7R, 1 μ F, 16V, 0805	MURATA, GRM21BR71C105KA01
14	1	C6	CAP., X7R, 2.2 μ F, 100V, 1210	MURATA, GRM32ER72A225KA01
15	1	C5	CAP., ELEC., 10 μ F, 100V	NIC COMP, NACEW100M100V6.3X8TR13F
16	1	D1	DIODE, 58V, 400W, TVS, SMA-DIODE	DIODES INC., SMAJ58A-13-F
17	2	D11, D16	DIODE, FAST SWITCHING, SOT23	DIODES INC., BAS21-7-F
18	1	D14	DIODE, SCHOTTKY, SOT23	DIODES INC., BAT54-7-F
19	1	L1	INDUCTOR, 180 μ H, DO1813H-181MLB	COILCRAFT, DO1813H-181MLB
20	1	L2	INDUCTOR, 10 μ H, DO1608C-103MLB	COILCRAFT, DO1608C-103MLB
21	1	Q1	MOSFET, N-CH, 150V, 4.1A, S08	FAIRCHILD, FDS2582
22	1	Q2	MOSFET, N-CH, 30-V, S08	FAIRCHILD, FDS8880
23	1	Q6	TRANSISTOR, PNP, SILICON POWER, SOT23	ON SEMI., MMBT3906
24	1	Q7	TRANSISTOR, NPN, SILICON POWER, SOT23	ON SEMI., MMBT3904
25	1	R9	RES., CHIP, 39k, 1/4W, 5%, 1206	VISHAY, CRCW120639K0JNEA
26	1	R13	RES., CHIP, 27.4k, 1/10W, 1%, 0603	VISHAY, CRCW060327K4FKEA
27	1	R16	RES., CHIP, 0.033 Ω , 1/8W, 1%, 1206	IRC, LRC-LRF1206LF-01-R033-F
28	1	R22	RES., CHIP, 15 Ω , 1/16W, 5%, 0603	VISHAY, CRCW060315R0JNEA
29	1	R25	RES., CHIP, 1.21k, 1/16W, 1%, 0603	VISHAY, CRCW06031K21FKEA
30	1	R27	RES., CHIP, 10k, 1/16W, 1%, 0603	VISHAY, CRCW060310K0FKEA
31	1	R10	RES., CHIP, 20 Ω , 1/10W, 5%, 0805	VISHAY, CRCW080520R0JNEA
32	1	R34	RES., CHIP, 5.1 Ω , 1/4W, 5%, 1206	VISHAY, CRCW12065R10JNEA
33	1	R36	RES., CHIP, 30.9 Ω , 1/16W, 1%, 0603	VISHAY, CRCW060330R9FKEA
34	1	R17	RES., CHIP, 100 Ω , 1/16W, 1%, 0603	VISHAY, CRCW0603100RFKEA
35	1	R2	RES., CHIP, 150 Ω , 1/4W, 5%, 1206	VISHAY, CRCW1206150RJNEA
36	1	R20	RES., CHIP, 3.01k, 1/16W, 1%, 0603	VISHAY, CRCW06033K01FKEA
37	1	R28	RES., CHIP, 10k, 1/16W, 5%, 0603	VISHAY, CRCW060310K0JKEA
38	1	R23	RES., CHIP, 12k, 1/16W, 5%, 0603	VISHAY, CRCW060312K0JKEA
39	1	R19	RES., CHIP, 14.0k, 1/16W, 1%, 0603	VISHAY, CRCW060314K0FKEA
40	1	R26	RES., CHIP, 38.3k, 1/16W, 1%, 0603	VISHAY, CRCW060338K3FKEA
41	1	R1	RES., CHIP, 51k, 1/16W, 1%, 0603	VISHAY, CRCW060351K0FKEA

DEMO MANUAL DC1335B-B

42	1	R24	RES., CHIP, 100k, 1/16W, 1%, 0603	VISHAY, CRCW0603100KFKEA
43	1	R12	RES., CHIP, 383k, 1/16W, 1%, 0603	VISHAY, CRCW0603383KFKEA
44	1	T1	XFMR, FLYBACK, PA2369NL	PULSE, PA2369NL
45	0	T1 (ALTERNATE)	XFMR, FLYBACK, EPC3409G-LF	PCA ELEC., EPC3409G-LF
46	1	T2	XFMR, GATE DRIVE	PULSE, PE-68386NL
47	1	U1	IC, LTC4269IDKD-1, DFN32	LINEAR TECH., LTC4269IDKD-1
48	1	U2	IC, OPTOCOUPERS PS2801-1-L	NEC, PS2801-1-F3--L-A

Additional Demo Board Circuit Components²

1	0	C9	OPT, 1206	
2	1	C17	CAP, X7R, 1000pF, 2KV, 1808	AVX, 1808GC102MAT
3	4	C13, C14, C15, C16	CAP, X7R, 0.01μF, 100V, 0805	MURATA, GRM21BR72A103KA01
4	0	C25, C31	OPT, 0603	
5	8	D2-D9	DIODE, SCHOTTKY, 1A, SMA-DIODE	DIODES INC., B1100-13-F
6	0	D10	OPT.	
7	1	D12	DIODE, 1A, PASSIVATED RECTIFIER	DIODES INC., S1B-13-F
8	1	D13	DIODE, SMT ZENER, 36V, 400mW	NXP, PDZ36B
9	1	D15	LED, SMT GREEN	PANASONIC, LN1351C-(TR)
10	14	E1-E14	TP, TURRET, 0.094"	MILL-MAX, 2501-2-00-80-00-00-07-0
11	1	J1	CONN., RJ-45 RIGHT ANGLE, RJ45	STEWART CONN. SYS., SS-6488-NF-K1
12	0	J2	OPT., JUMPER, 2X3, .079CC, HD2X3-079	
13	1	Q5	TRANSISTOR, PNP, SILICON POWER, SOT23	ON SEMI., BSS63LT1
14	1	R11	RES., CHIP, 0Ω, JUMPER, 0603	PANASONIC, ERJ3GEY0R00V
15	4	R4, R5, R6, R7	RES., CHIP, 75Ω, 1/16W, 5%, 0603	VISHAY, CRCW060375R0JNEA
16	0	R15	OPT, 0805	
17	1	R18	RES., CHIP, 10.0k, 1/16W, 1%, 0603	VISHAY, CRCW060310K0FKEA
18	1	R8	RES., CHIP, 20k, 1/16W, 5%, 0603	VISHAY, CRCW060320K0JKEA
19	1	R21	RES., CHIP, 24k, 1/16W, 5%, 0603	VISHAY, CRCW060324K0JKEA
20	1	R14	RES., CHIP, 107k, 1/16W, 1%, 0603	VISHAY, CRCW0603107KFKEA
21	1	R33	RES., CHIP, 620Ω, 1/16W, 1%, 0603	VISHAY, CRCW0603620RFKEA
22	1	R35	RES., CHIP, 0Ω, JUMPER, 0603	PANASONIC, ERJ3GEY0R00V
23	1	T3	XFMR, POE PLUS, ETH1-230LD	COILCRAFT, ETH1-230LB
24	4	for 4 Corners	STAND-OFF, NYLON (SNAP ON), 0.625" TALL	KEystone, 8834

SCHEMATIC DIAGRAM

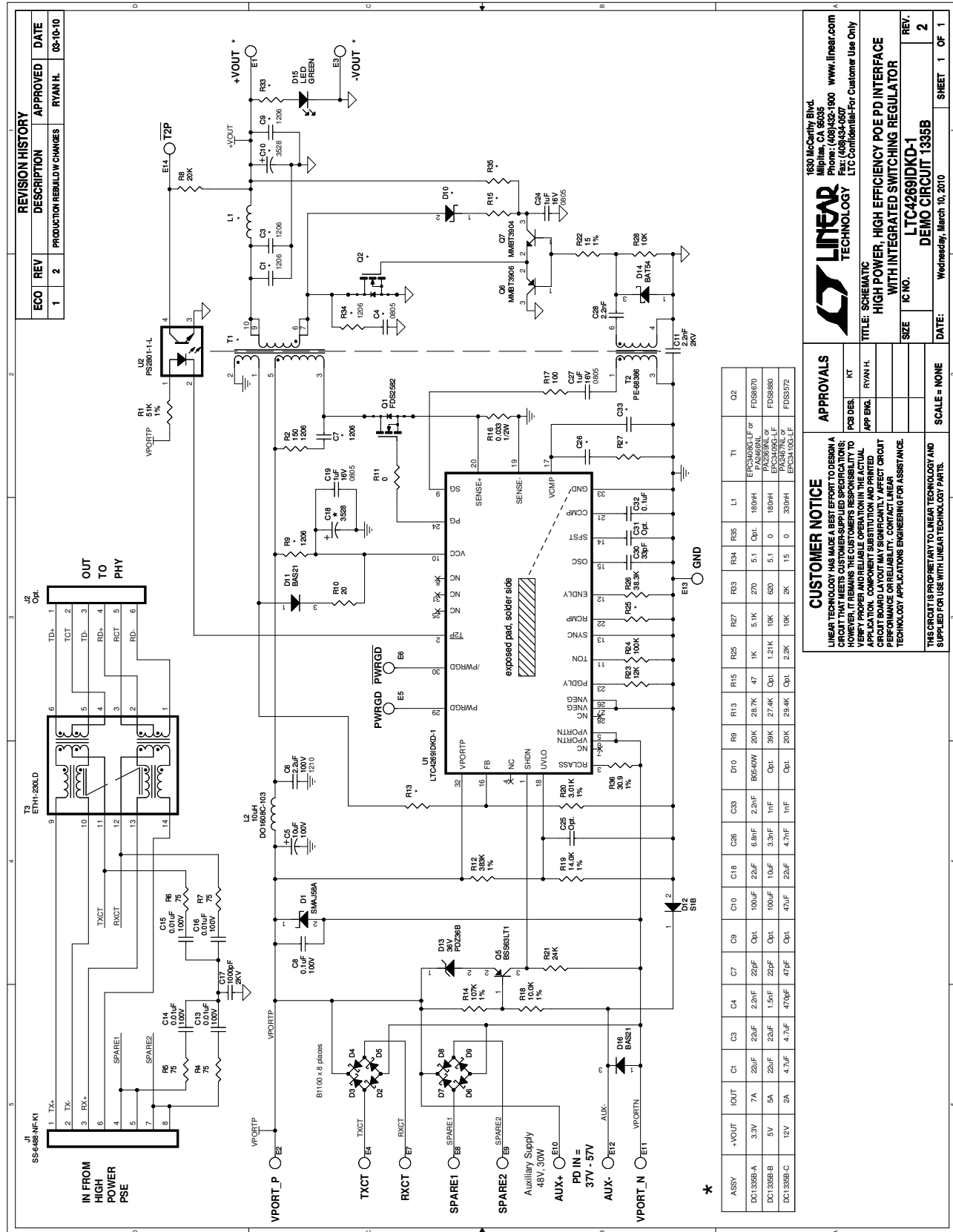

dc1335bbf

DEMO MANUAL DC1335B-B

DEMONSTRATION BOARD IMPORTANT NOTICE

Linear Technology Corporation (LTC) provides the enclosed product(s) under the following **AS IS** conditions:

This demonstration board (DEMO BOARD) kit being sold or provided by Linear Technology is intended for use for **ENGINEERING DEVELOPMENT OR EVALUATION PURPOSES ONLY** and is not provided by LTC for commercial use. As such, the DEMO BOARD herein may not be complete in terms of required design-, marketing-, and/or manufacturing-related protective considerations, including but not limited to product safety measures typically found in finished commercial goods. As a prototype, this product does not fall within the scope of the European Union directive on electromagnetic compatibility and therefore may or may not meet the technical requirements of the directive, or other regulations.

If this evaluation kit does not meet the specifications recited in the DEMO BOARD manual the kit may be returned within 30 days from the date of delivery for a full refund. **THE FOREGOING WARRANTY IS THE EXCLUSIVE WARRANTY MADE BY THE SELLER TO BUYER AND IS IN LIEU OF ALL OTHER WARRANTIES, EXPRESSED, IMPLIED, OR STATUTORY, INCLUDING ANY WARRANTY OF MERCHANTABILITY OR FITNESS FOR ANY PARTICULAR PURPOSE. EXCEPT TO THE EXTENT OF THIS INDEMNITY, NEITHER PARTY SHALL BE LIABLE TO THE OTHER FOR ANY INDIRECT, SPECIAL, INCIDENTAL, OR CONSEQUENTIAL DAMAGES.**

The user assumes all responsibility and liability for proper and safe handling of the goods. Further, the user releases LTC from all claims arising from the handling or use of the goods. Due to the open construction of the product, it is the user's responsibility to take any and all appropriate precautions with regard to electrostatic discharge. Also be aware that the products herein may not be regulatory compliant or agency certified (FCC, UL, CE, etc.).

No License is granted under any patent right or other intellectual property whatsoever. **LTC assumes no liability for applications assistance, customer product design, software performance, or infringement of patents or any other intellectual property rights of any kind.**

LTC currently services a variety of customers for products around the world, and therefore this transaction **is not exclusive**.

Please read the DEMO BOARD manual prior to handling the product. Persons handling this product must have electronics training and observe good laboratory practice standards. **Common sense is encouraged.**

This notice contains important safety information about temperatures and voltages. For further safety concerns, please contact a LTC application engineer.

Mailing Address:

Linear Technology
1630 McCarthy Blvd.
Milpitas, CA 95035

Copyright © 2004, Linear Technology Corporation

dc1335bbf