



The following document contains information on Cypress products. Although the document is marked with the name "Spansion" and "Fujitsu", the company that originally developed the specification, Cypress will continue to offer these products to new and existing customers.

Continuity of Specifications

There is no change to this document as a result of offering the device as a Cypress product. Any changes that have been made are the result of normal document improvements and are noted in the document history page, where supported. Future revisions will occur when appropriate, and changes will be noted in a document history page.

Continuity of Ordering Part Numbers

Cypress continues to support existing part numbers. To order these products, please use only the Ordering Part Numbers listed in this document.

For More Information

Please contact your local sales office for additional information about Cypress products and solutions.

About Cypress

Cypress (NASDAQ: CY) delivers high-performance, high-quality solutions at the heart of today's most advanced embedded systems, from automotive, industrial and networking platforms to highly interactive consumer and mobile devices. With a broad, differentiated product portfolio that includes NOR flash memories, F-RAM™ and SRAM, Traveo™ microcontrollers, the industry's only PSoC® programmable system-on-chip solutions, analog and PMIC Power Management ICs, CapSense® capacitive touch-sensing controllers, and Wireless BLE Bluetooth® Low-Energy and USB connectivity solutions, Cypress is committed to providing its customers worldwide with consistent innovation, best-in-class support and exceptional system value.

ASSP For Power Supply Applications

BIPOLAR

Switching Regulator Controller (Low Voltage)

MB3800

■ DESCRIPTION

The MB3800 is a single-channel switching regulator control IC for low voltage applications incorporating a soft start function and short circuit detection function. The device has a low minimum operating voltage of 1.8 V and is ideal for the power supply of battery-operated electronic equipment.

■ FEATURES

- Wide supply voltage operating range: 1.8 V to 15 V
- Low current consumption: Typically 5.5 mA in operation, 1 μ A or less in stand-by
- High speed operation is possible: Maximum 1 MHz
- The error amplifier gain is set inside the IC, so peripheral components are minimized.
- Incorporates a soft start circuit.
- Incorporates a timer-latch type short circuit detection circuit (SCP).
- Totem-pole type output with adjustable on/off current (for NPN transistors)
- Incorporates a stand-by function.
- Three types of packages (SOP-8 : 2 types, SSOP-8 : 1 type)

■ Application

- LCD monitor/panel
- Power supply module
- Portable apparatus etc.

MB3800

■ PIN ASSIGNMENT

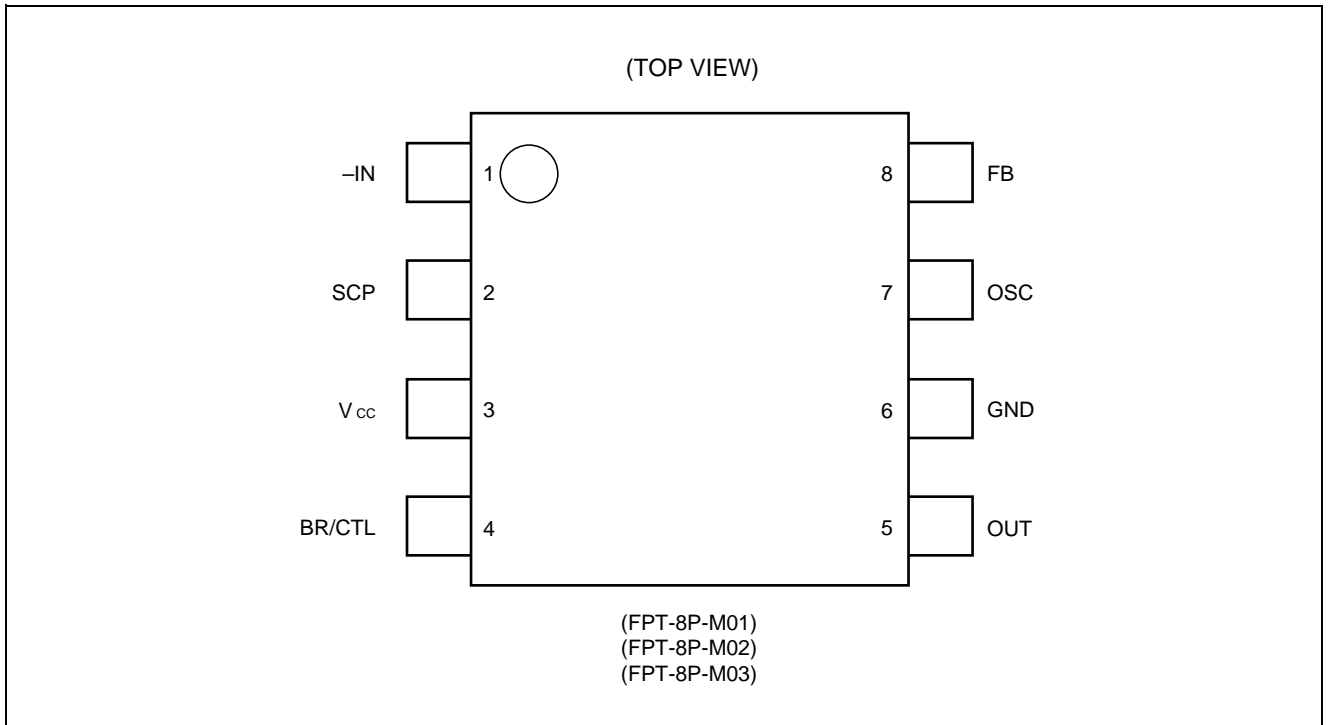

■ PIN DESCRIPTION

Pin No.	Symbol	I/O	Description
1	-IN	I	Error amplifier inverting input pin
2	SCP	—	Soft start and SCP setting capacitor connection pin
3	V _{cc}	—	Power supply pin
4	BR/CTL	I	Output current setting and control pin
5	OUT	O	Totem-pole type output pin
6	GND	—	Ground pin
7	OSC	—	Capacitor and resistor connection pin for setting the oscillation frequency
8	FB	O	Error amplifier output pin

■ BLOCK DIAGRAM

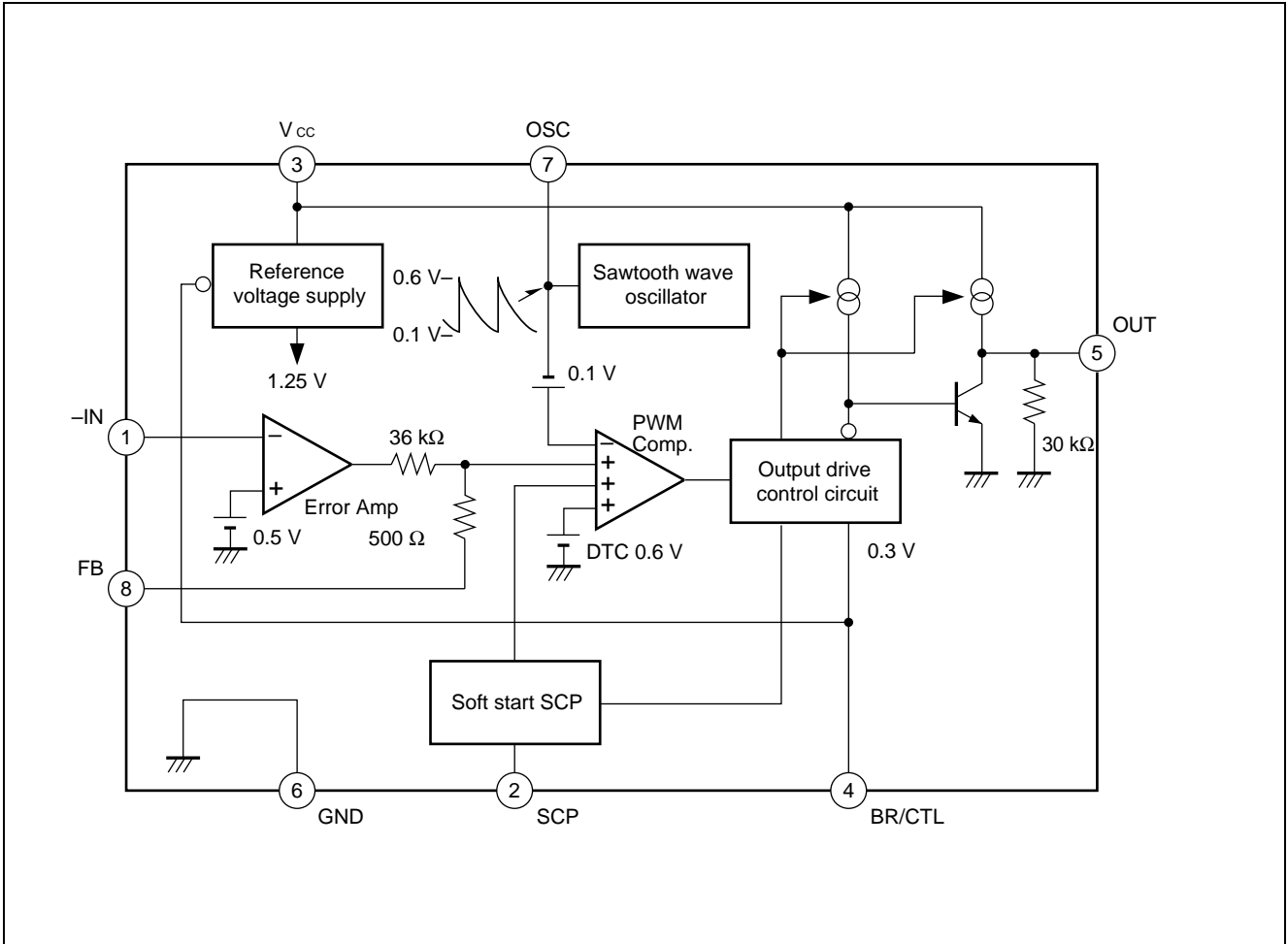

MB3800

■ ABSOLUTE MAXIMUM RATINGS

Parameter	Symbol	Condition	Rating		Unit
			Min	Max	
Power supply voltage	V_{CC}	—	—	16	V
Output source current	I_{O+}		—	-50	mA
Output sink current	I_{O-}		—	50	mA
Allowable dissipation	P_D	FPT-8P-M01, $T_a \leq +25^\circ\text{C}$	—	570*	mW
		FPT-8P-M02, $T_a \leq +25^\circ\text{C}$	—	430*	mW
		SSOP-8, $T_a \leq +25^\circ\text{C}$	—	580*	mW
Storage temperature	T_{stg}	—	-55	+125	$^\circ\text{C}$

*: When mounted on a 10 cm square double-sided epoxy board.

WARNING: Semiconductor devices can be permanently damaged by application of stress (voltage, current, temperature, etc.) in excess of absolute maximum ratings. Do not exceed these ratings.

■ RECOMMENDED OPERATING CONDITIONS

($T_a = +25^\circ\text{C}$)

Parameter	Symbol	Value			Unit
		Min	Typ	Max	
Power supply voltage	V_{CC}	1.8	—	15	V
Error amplifier input voltage	V_I	-0.2	—	+1.0	V
BR/CTL pin input voltage	V_{BR}	-0.2	—	V_{CC}	V
Output source current	I_{O+}	-40	—	—	mA
Output sink current	I_{O-}	—	—	40	mA
SCP pin capacitance	C_{PE}	—	0.1	—	μF
Phase compensation capacitance	C_P	—	0.1	—	μF
Output current setting resistance	R_B	150	390	5000	Ω
Timing resistance	R_T	1.0	3.0	10.0	k Ω
Timing capacitance	C_T	100	270	10000	pF
Oscillation frequency	f_{OSC}	10	500	1000	kHz
Operating Ambient temperature	T_a	-30	+25	+85	$^\circ\text{C}$

WARNING: The recommended operating conditions are required in order to ensure the normal operation of the semiconductor device. All of the device's electrical characteristics are warranted when the device is operated within these ranges.

Always use semiconductor devices within their recommended operating condition ranges. Operation outside these ranges may adversely affect reliability and could result in device failure.

No warranty is made with respect to uses, operating conditions, or combinations not represented on the data sheet. Users considering application outside the listed conditions are advised to contact their representatives beforehand.

■ ELECTRICAL CHARACTERISTICS

(VCC = +2 V, Ta = +25 °C)

Parameter		Symbol	Condition	Value			Unit
				Min	Typ	Max	
Circuit to prevent malfunction at low input voltage (U.V.L.O.)	Reset voltage	V_R	—	—	—	0.9	V
	Threshold voltage	V_{TH}		1.1	1.3	1.5	V
Soft start	Charging current	I_{CS}	$V_{SCP} = 0\text{ V}$	-1.5	-1.0	-0.7	μA
	Voltage at soft start completion	V_{IS}	—	0.7	0.8	0.9	V
Short circuit detection (S.C.P.)	Charging current	I_{CPC}	$V_{SCP} = 0\text{ V}$	-1.5	-1.0	-0.7	μA
	Threshold voltage	V_{IPC}	—	0.7	0.8	0.9	V
Sawtooth wave oscillator (OSC)	Oscillation frequency	f_{OCS}	$R_T = 3.0\text{ k}\Omega$, $C_T = 270\text{ pF}$	400	500	600	kHz
	Frequency input stability	f_{dV}	$V_{CC} = 2\text{ V to }15\text{ V}$	—	2	10	%
	Frequency variation with temperature	f_{dT}	$T_a = -30^\circ\text{C to }+85^\circ\text{C}$	—	5	—	%
Error amplifier	Input threshold voltage	V_T	$V_{FB} = 450\text{ mV}$	480	500	520	mV
	V_T input stability	V_{TdV}	$V_{CC} = 2\text{ V to }15\text{ V}$	—	5	20	mV
	V_T variation with temperature	V_{TdT}	$T_a = -30^\circ\text{C to }+85^\circ\text{C}$	—	1	—	%
	Input bias current	I_B	$V_{IN} = 0\text{ V}$	-1.0	-0.2	+1.0	μA
	Voltage gain	A_V	—	70	100	145	V/V
	Frequency bandwidth	BW	$A_V = 0\text{ dB}$	—	6	—	MHz
	Maximum output voltage range	V_{OM+}	—	0.78	0.87	—	V
		V_{OM-}		—	0.05	0.2	V
Output source current	I_{OM+}	$V_{FB} = 0.45\text{ V}$	—	-40	-24	μA	
Output sink current	I_{OM-}		24	40	—	μA	
Idle period adjustment section	Maximum duty cycle	t_{DUTY}	$R_T = 3.0\text{ k}\Omega$, $C_T = 270\text{ pF}$ $V_{FB} = 0.8\text{ V}$	65	75	85	%

(Continued)

MB3800

(Continued)

Parameter	Symbol	Condition	Value			Unit	
			Min	Typ	Max		
Output section	V_{OH1}	$R_B = 390 \Omega, I_o = -15 \text{ mA}$	1.0	1.2	—	V	
	V_{OH2}	$R_B = 750 \Omega, V_{CC} = 1.8 \text{ V}$ $I_o = -10 \text{ mA}$	0.8	1.0	—	V	
	V_{OL1}	$R_B = 390 \Omega, I_o = 15 \text{ mA}$	—	0.1	0.2	V	
	V_{OL2}	$R_B = 750 \Omega, V_{CC} = 1.8 \text{ V}$ $I_o = 10 \text{ mA}$	—	0.1	0.2	V	
	Output source current	I_o^+	$R_B = 390 \Omega, V_o = 0.9 \text{ V}$	—	-30	-20	mA
	Output sink current	I_o^-	$R_B = 390 \Omega, V_o = 0.3 \text{ V}$	30	60	—	mA
	Pull down resistance	R_o	—	20	30	40	k Ω
Output current setting section/ Control section	Pin voltage	V_{BR}	$R_B = 390 \Omega$	0.2	0.3	0.4	V
	Input off condition	I_{OFF}	—	-20	—	0	μA
	Input on condition	I_{ON}	—	—	—	-45	μA
	Pin current range	I_{BR}	—	-1.8	—	-0.1	mA
Entire device	Stand-by current	I_{CCS}	BR/CTL pin open or V_{CC}	—	—	1	μA
	Average supply current	I_{CC}	$R_B = 390 \Omega$	—	5.5	9.3	mA

■ DIAGRAM

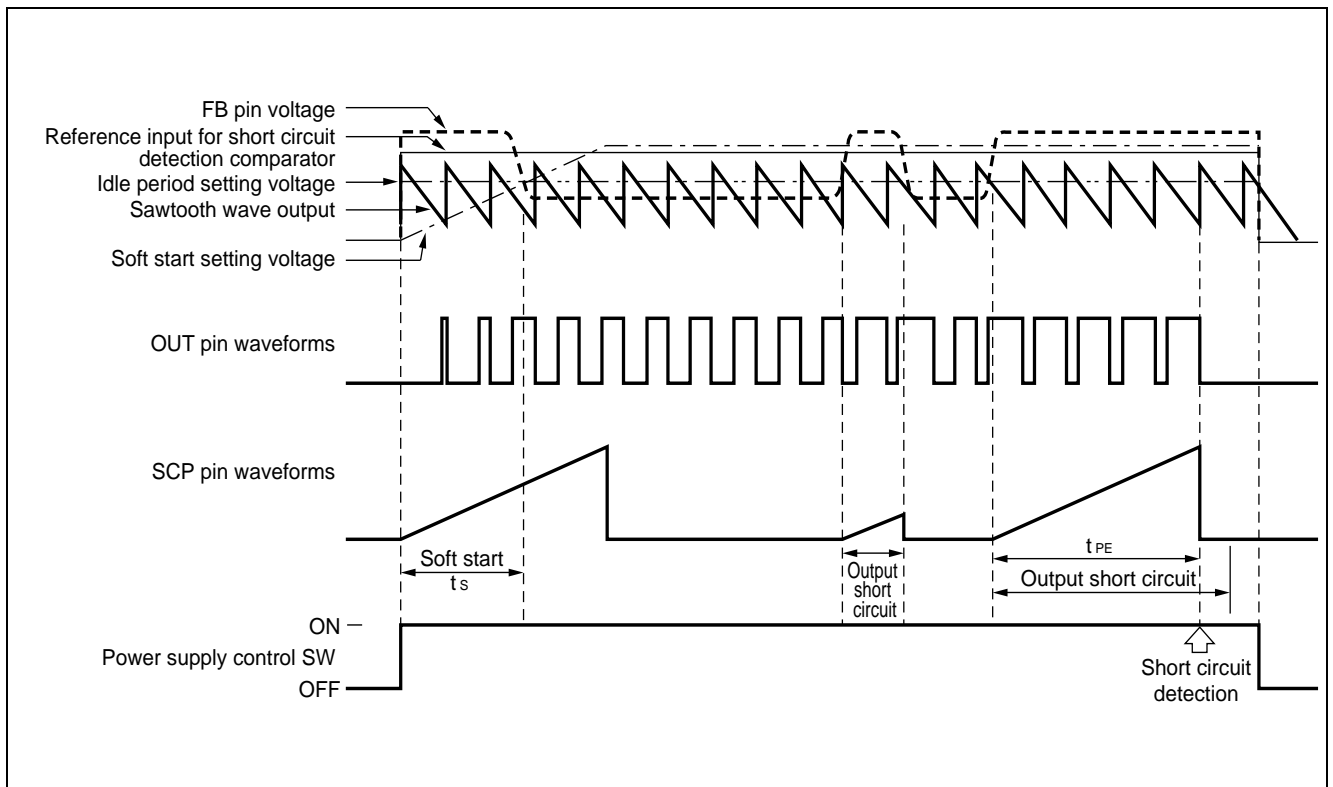

■ HOW TO SET THE TIME CONSTANT FOR SOFT START AND SHORT CIRCUIT DETECTION

1. Soft Start

At power on, the capacitor C_{PE} connected to the SCP pin (pin 2) starts charging. The PWM comparator compares the soft start setting voltage as a proportion of the voltage at the SCP pin with the sawtooth waveform.

The comparison controls the ON duty of the OUT pin (pin 5), causing the soft start operation. On completion of soft start operation, the voltage at the SCP pin stays low, the soft start setting voltage stays high, and the circuit enters the output short circuit detection wait state.

Soft start time (The time until the output ON duty reaches approximately 50%)

$$t_s [s] \cong 0.35 \times C_{PE} [\mu F]$$

2. Short Circuit Protection

If the switching regulator output suddenly drops due to load effect, the error amplifier output (FB pin (pin 8)) is fixed at V_{OM}^+ and capacitor C_{PE} starts charging. When the voltage at the SCP pin reaches approximately 0.8 V, the OUT pin (pin 5) is set low and the SCP pin (pin 2) stays low.

Once the protection circuit operates, the circuit can be restored by resetting the power supply.

- Short circuit detection time

$$t_{PE} [s] \cong 0.8 \times C_{PE} [\mu F]$$

MB3800

■ TYPICAL CHARACTERISTICS

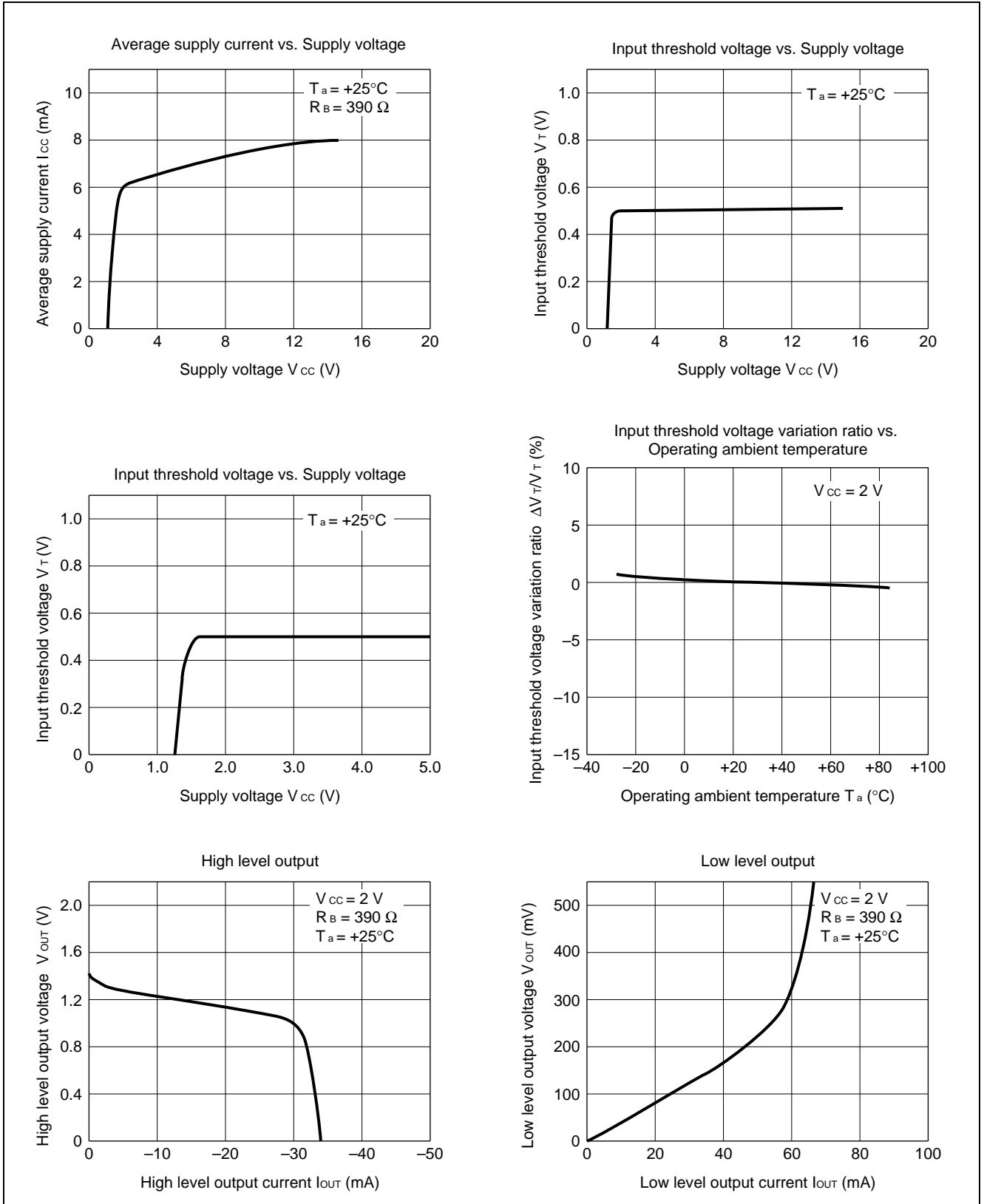

(Continued)

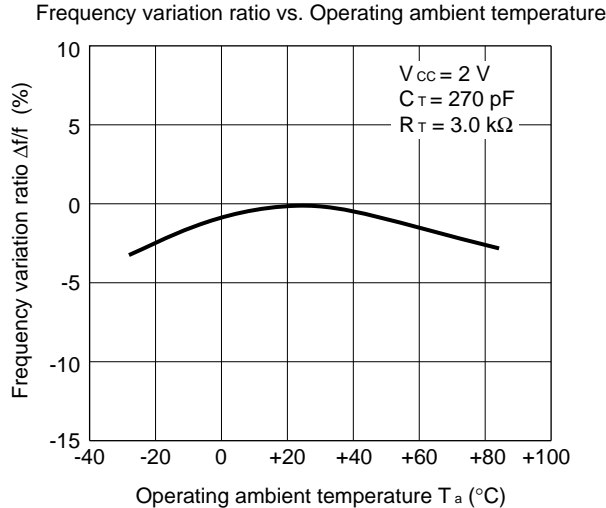
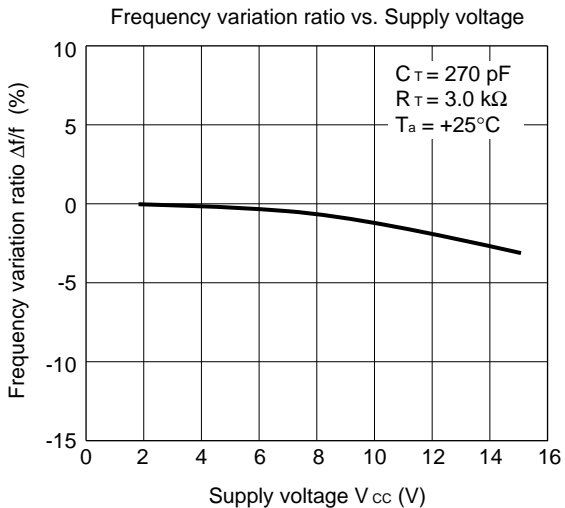
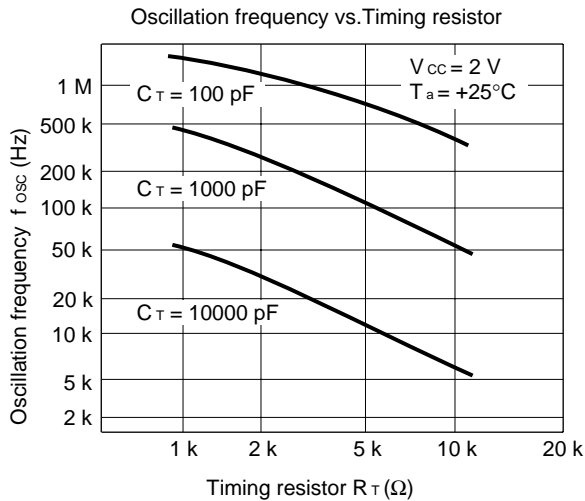
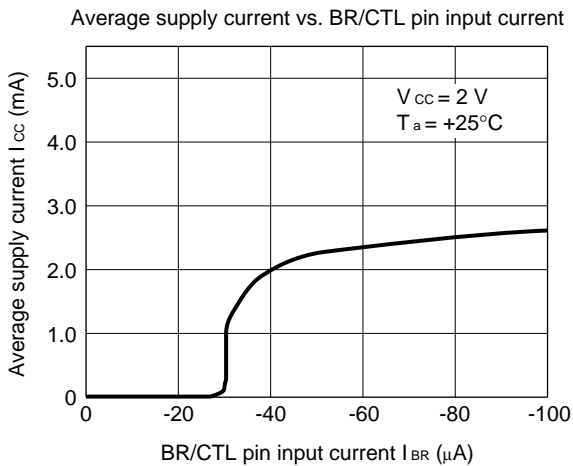
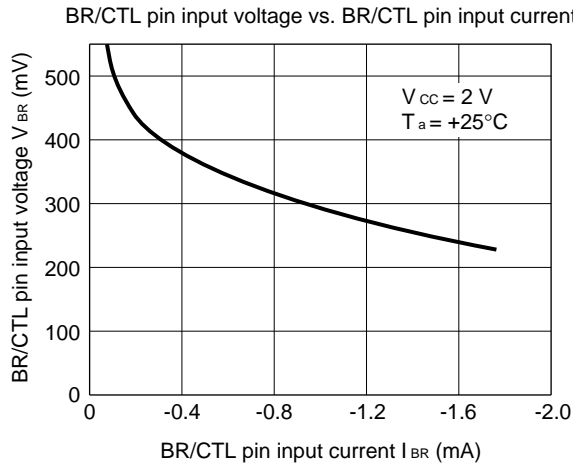
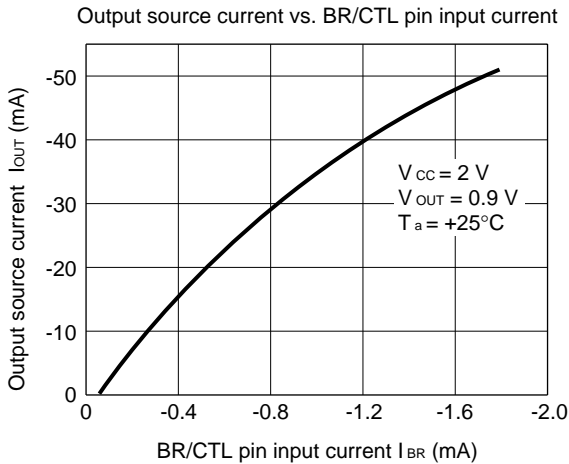

(Continued)

MB3800

(Continued)

Maximum duty cycle vs. Oscillation frequency

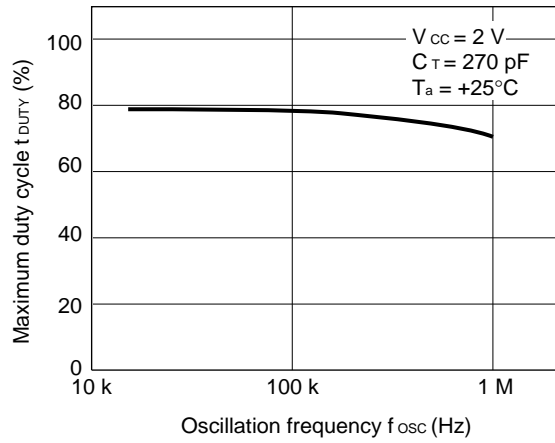

Output pin voltage and current waveforms (reference data)

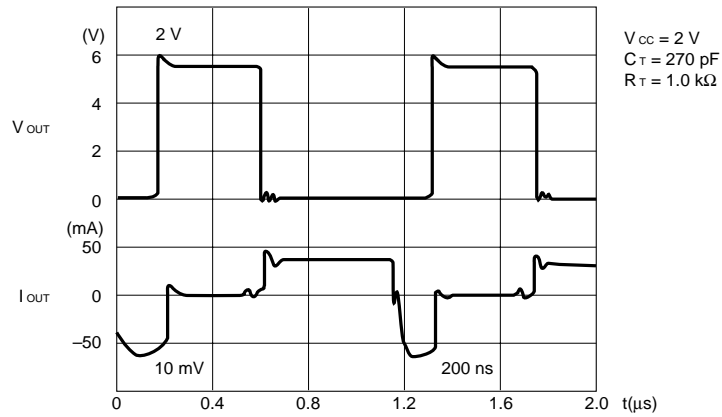

Note: The OFF delay time of V_{OUT} depends on the characteristics of the external transistor.

Measurement circuit diagram

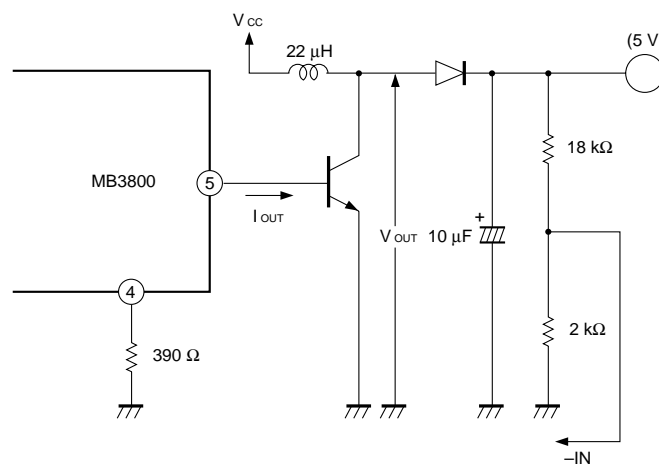

■ FUNCTIONAL DESCRIPTION

1. Switching Regulator Function

(1) Reference voltage circuit

The reference voltage circuit generates a temperature-compensated reference voltage ($\cong 1.25V$) from voltage supplied from the V_{CC} pin (pin 3). In addition to providing the reference voltage for the switching regulator, the circuit also sets the idle period.

(2) Sawtooth wave oscillator

The sawtooth oscillator generates a sawtooth wave (up to 1 MHz) that is stable with respect to the supply voltage and temperature. The capacitor and resistor that set the oscillation frequency are connected to the OSC pin (pin 7).

(3) Error amplifier (Error Amp)

The error amplifier detects the output voltage of the switching regulator and outputs the PWM control signal. The voltage gain is fixed, and connecting a phase compensation capacitor to the FB pin (pin 8) provides stable phase compensation for the system.

(4) PWM comparator (PWM Comp.)

The voltage comparator has one inverting and three non-inverting inputs. The comparator is a voltage/pulse width converter that controls the ON time of the output pulse depending on the input voltage. The output level is high (H) when the sawtooth wave is lower than the error amplifier output voltage, soft start setting voltage, and idle period setting voltage.

(5) Output circuit

The output circuit has a totem pole type configuration and can drive an external NPN transistor directly. The value of the ON/OFF current can be set by a resistor connected to the BR/CTL pin (pin 4).

2. Power Supply Control Function

Stand-by mode (supply current $1 \mu A$ or less) can be set by connecting the BR/CTL pin (pin 4) to V_{CC} or by making the pin open circuit.

SW	Mode
OFF	Stand-by mode
ON	Operating mode

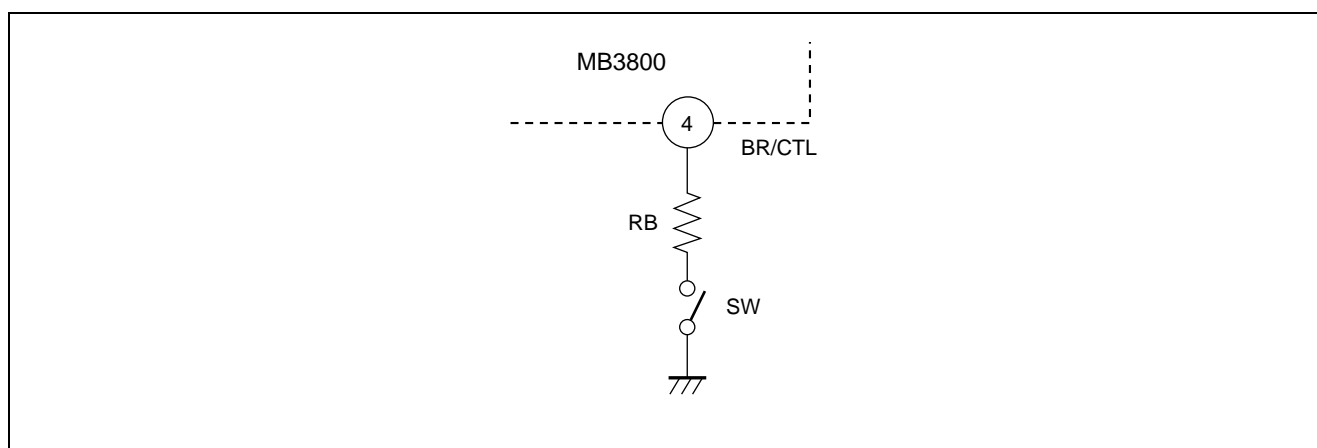

MB3800

3. Other Functions

(1) Soft start and short circuit detection

Soft start operation is set by connecting capacitor C_{PE} to the SCP pin (pin 2). Soft start prevents a current spike on start-up.

On completion of soft start operation, the SCP pin (pin 2) stays low and enters the short circuit detection wait state. When an output short circuit occurs, the error amplifier output is fixed at V_{OM+} and capacitor C_{PE} starts charging. After charging to approximately 0.8 V, the OUT pin (pin 5) is set low and the SCP pin (pin 2) stays low.

Once the protection circuit operates, the circuit can be restored by resetting the power supply. (See "■ HOW TO SET THE TIME CONSTANT FOR SOFT START AND SHORT CIRCUIT DETECTION".)

(2) Circuit to prevent malfunction at low input voltage

Transients when powering on or instantaneous glitches in the supply voltage can lead to malfunction of the control IC and cause system damage or failure. The circuit to prevent malfunction at low input voltage detects a low input voltage by comparing the supply voltage to the internal reference voltage. On detection, the circuit fixes the OUT pin (pin 5) to low.

The system recovers when the supply voltage rises back above the threshold voltage of the malfunction prevention circuit.

■ APPLICATION EXAMPLE

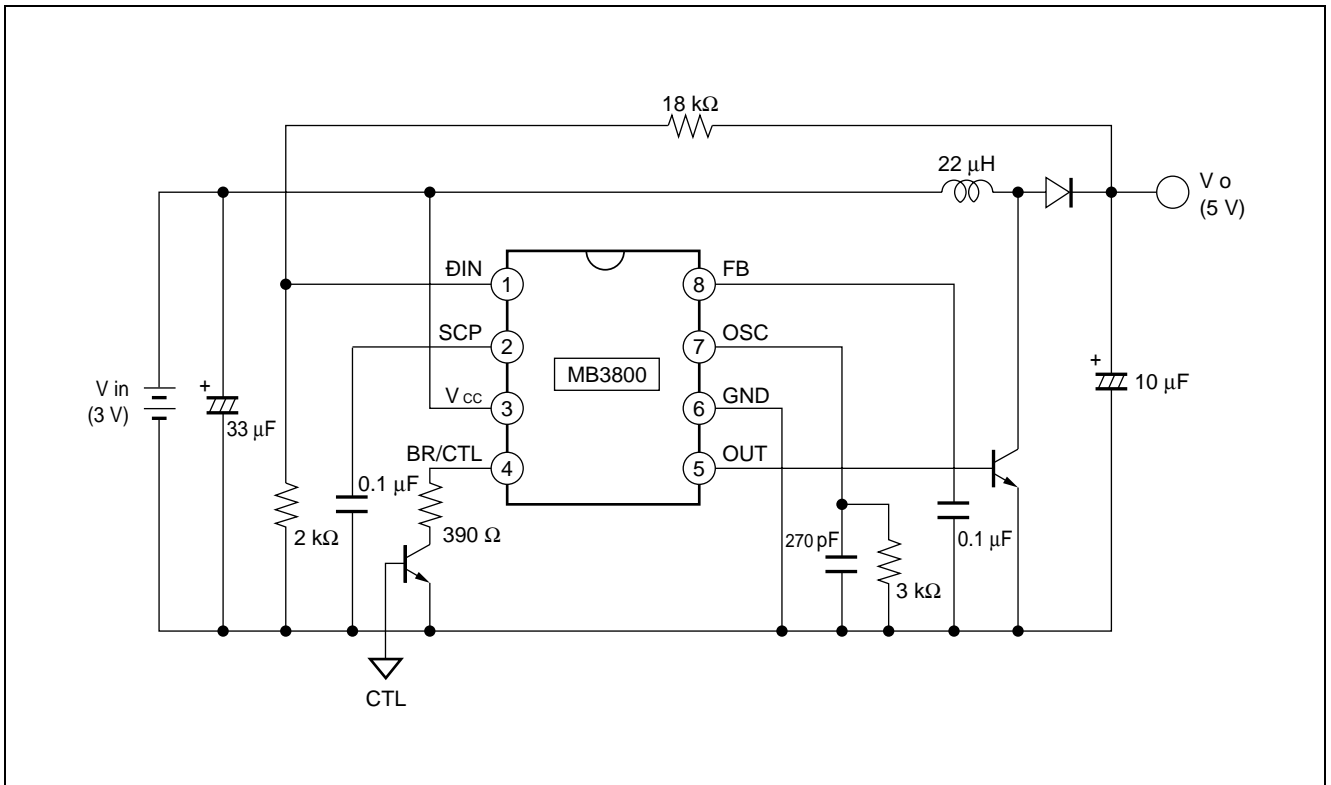

■ NOTES ON USE

- Take account of common impedance when designing the earth line on a printed wiring board.
- Take measures against static electricity.
 - For semiconductors, use antistatic or conductive containers.
 - When storing or carrying a printed circuit board after chip mounting, put it in a conductive bag or container.
 - The work table, tools and measuring instruments must be grounded.
 - The worker must put on a grounding device containing 250 kΩ to 1 MΩ resistors in series.
- Do not apply a negative voltage
 - Applying a negative voltage of -0.3 V or less to an LSI may generate a parasitic transistor, resulting in malfunction.

■ ORDERING INFORMATION

Part number	Package	Remarks
MB3800PF-□□□	8-pin Plastic SOP (FPT-8P-M01)	Conventional version
MB3800PNF-□□□	8-pin Plastic SOP (FPT-8P-M02)	Conventional version
MB3800PFV-□□□	8-pin Plastic SSOP (FPT-8P-M03)	Conventional version
MB3800PF-□□□E1	8-pin Plastic SOP (FPT-8P-M01)	Lead Free version
MB3800PNF-□□□E1	8-pin Plastic SOP (FPT-8P-M02)	Lead Free version
MB3800PFV-□□□E1	8-pin Plastic SSOP (FPT-8P-M03)	Lead Free version

■ RoHS Compliance Information of Lead (Pb) Free version

The LSI products of Fujitsu Microelectronics with "E1" are compliant with RoHS Directive , and has observed the standard of lead, cadmium, mercury, Hexavalent chromium, polybrominated biphenyls (PBB) , and polybrominated diphenyl ethers (PBDE) .

The product that conforms to this standard is added "E1" at the end of the part number.

MB3800

MARKING FORMAT (Lead Free version)

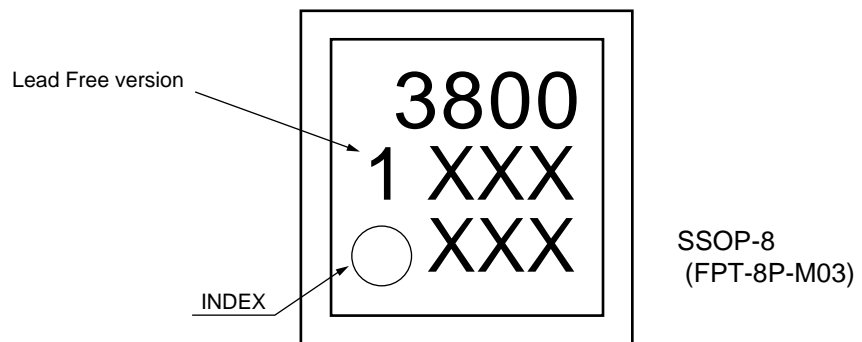
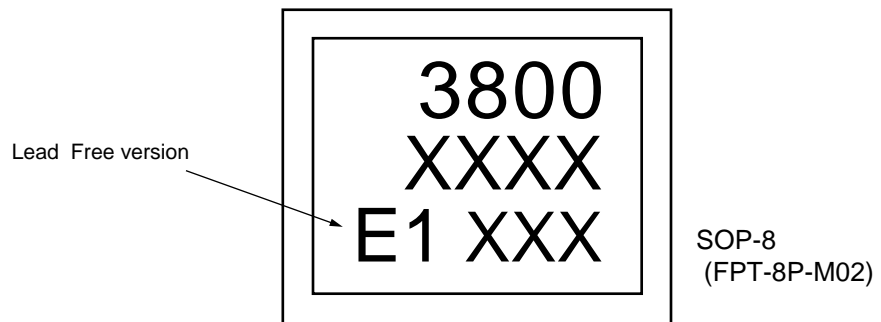
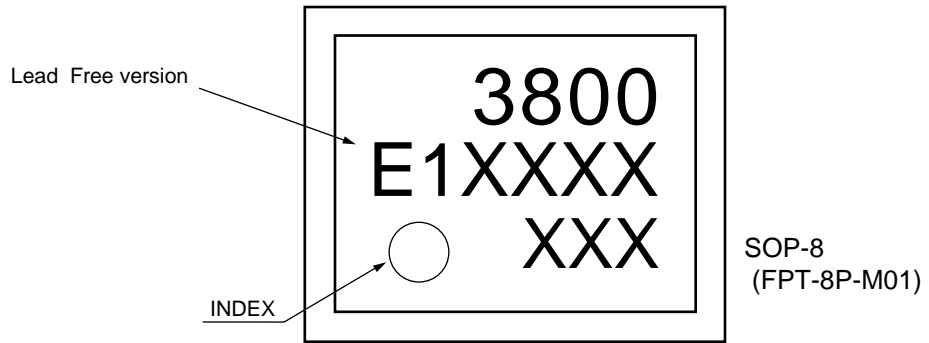

■ LABELING SAMPLE (Lead free version)

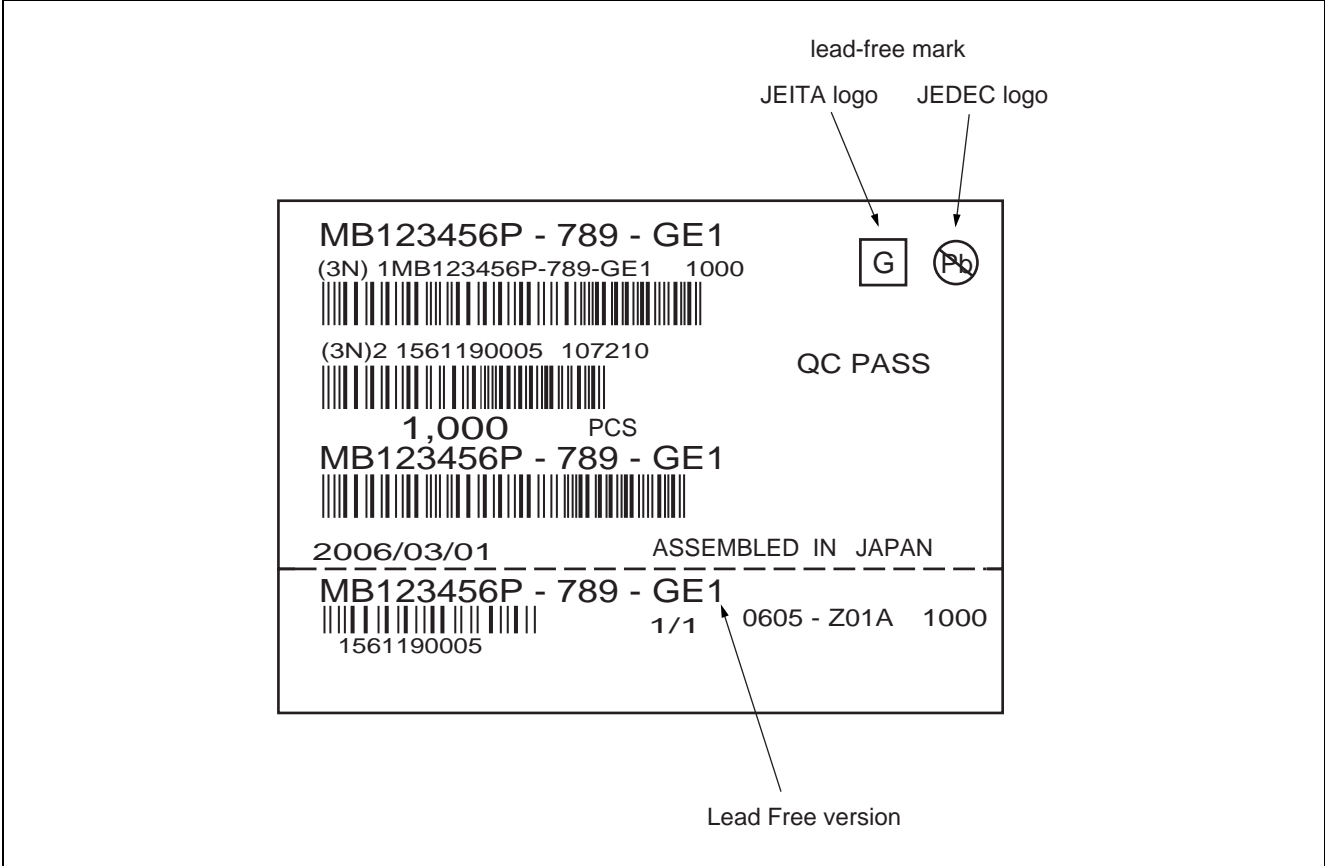

■ PACKAGE DIMENSIONS

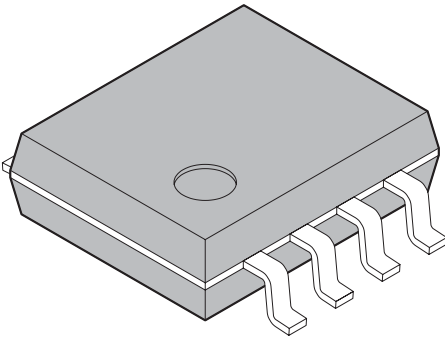
<p style="text-align: center;">8-pin plastic SOP</p>  <p style="text-align: center;">(FPT-8P-M01)</p>	Lead pitch	1.27 mm
	Package width × package length	5.3 × 6.35 mm
	Lead shape	Gullwing
	Sealing method	Plastic mold
	Mounting height	2.25 mm MAX
	Weight	0.10 g
	Code (Reference)	P-SOP8-5.3×6.35-1.27

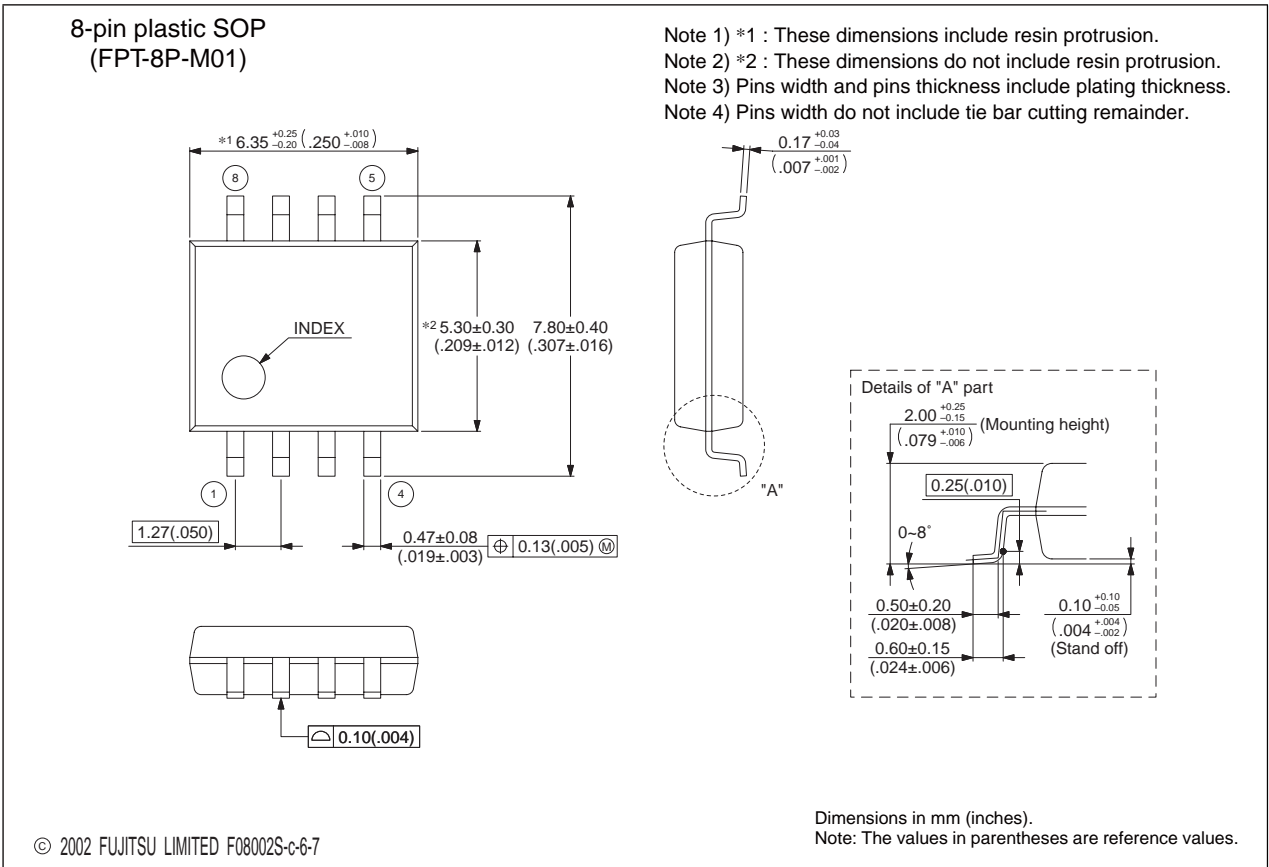

(Continued)

MB3800

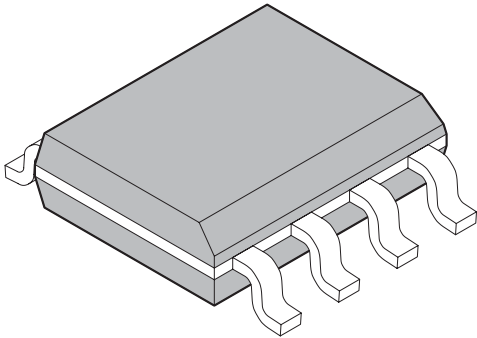
<p style="text-align: center;">8-pin plastic SOP</p>  <p style="text-align: center;">(FPT-8P-M02)</p>	Lead pitch	1.27 mm
	Package width × package length	3.9 × 5.05 mm
	Lead shape	Gullwing
	Sealing method	Plastic mold
	Mounting height	1.75 mm MAX
	Weight	0.06 g

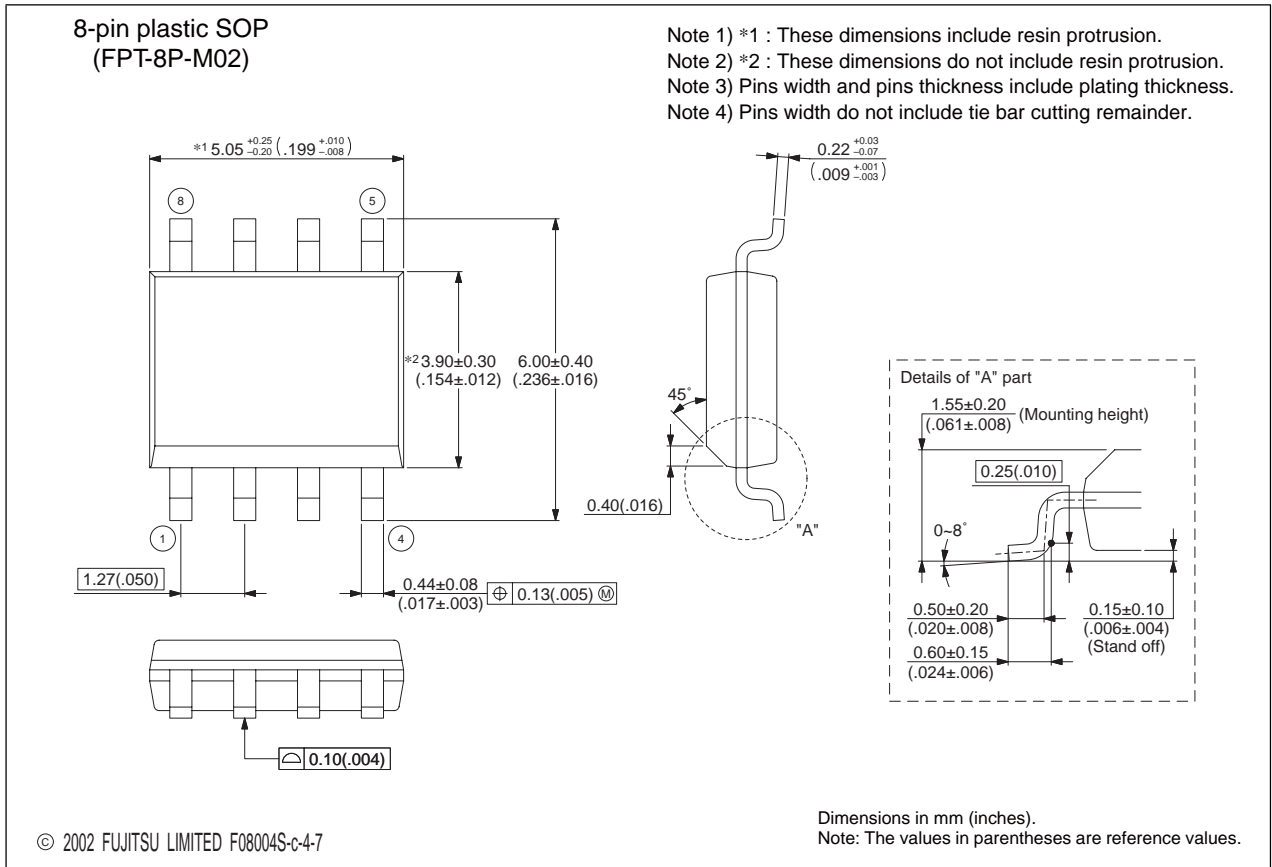

(Continued)

(Continued)

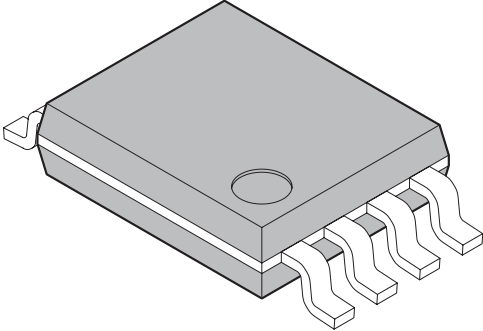
<p style="text-align: center;">8-pin plastic SSOP</p>  <p style="text-align: center;">(FPT-8P-M03)</p>	Lead pitch	0.80 mm
	Package width × package length	4.2 × 3.5 mm
	Lead shape	Gullwing
	Sealing method	Plastic mold
	Mounting height	1.45 mm MAX
	Weight	0.04 g
	Code (Reference)	P-SSOP8-4.2×3.5-0.80

8-pin plastic SSOP (FPT-8P-M03)

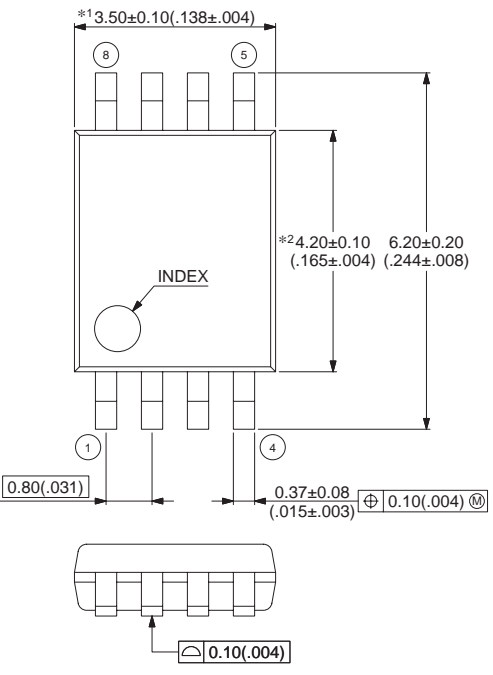

Note 1) *1 : Resin protrusion. (Each side : +0.15 (.006) Max).
 Note 2) *2 : These dimensions do not include resin protrusion.
 Note 3) Pins width and pins thickness include plating thickness.
 Note 4) Pins width do not include tie bar cutting remainder.

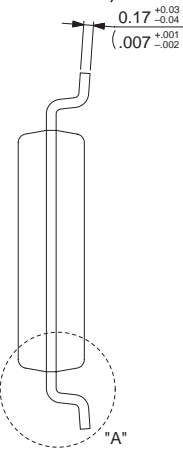

Details of "A" part

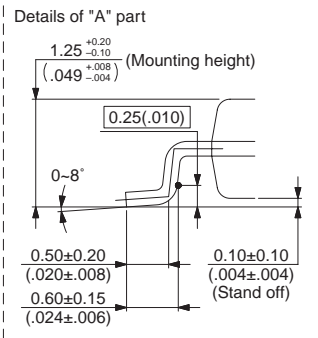

© 2002 FUJITSU LIMITED F08005S-c-3-5

Dimensions in mm (inches).
 Note: The values in parentheses are reference values.

FUJITSU MICROELECTRONICS LIMITED

Shinjuku Dai-Ichi Seimei Bldg. 7-1, Nishishinjuku 2-chome, Shinjuku-ku,
Tokyo 163-0722, Japan Tel: +81-3-5322-3347 Fax: +81-3-5322-3387
<http://jp.fujitsu.com/fml/en/>

For further information please contact:

North and South America

FUJITSU MICROELECTRONICS AMERICA, INC.
1250 E. Arques Avenue, M/S 333
Sunnyvale, CA 94085-5401, U.S.A.
Tel: +1-408-737-5600 Fax: +1-408-737-5999
<http://www.fma.fujitsu.com/>

Asia Pacific

FUJITSU MICROELECTRONICS ASIA PTE LTD.
151 Lorong Chuan, #05-08 New Tech Park,
Singapore 556741
Tel: +65-6281-0770 Fax: +65-6281-0220
<http://www.fujitsu.com/sg/services/micro/semiconductor/>

Europe

FUJITSU MICROELECTRONICS EUROPE GmbH
Pittlerstrasse 47, 63225 Langen,
Germany
Tel: +49-6103-690-0 Fax: +49-6103-690-122
<http://emea.fujitsu.com/microelectronics/>

FUJITSU MICROELECTRONICS SHANGHAI CO., LTD.
Rm.3102, Bund Center, No.222 Yan An Road(E),
Shanghai 200002, China
Tel: +86-21-6335-1560 Fax: +86-21-6335-1605
<http://cn.fujitsu.com/fmc/>

Korea

FUJITSU MICROELECTRONICS KOREA LTD.
206 KOSMO TOWER, 1002 Daechi-Dong,
Kangnam-Gu, Seoul 135-280
Korea
Tel: +82-2-3484-7100 Fax: +82-2-3484-7111
<http://www.fmk.fujitsu.com/>

FUJITSU MICROELECTRONICS PACIFIC ASIA LTD.
10/F., World Commerce Centre, 11 Canton Road
Tsimshatsui, Kowloon
Hong Kong
Tel: +852-2377-0226 Fax: +852-2376-3269
<http://cn.fujitsu.com/fmc/tw>

All Rights Reserved.

The contents of this document are subject to change without notice.

Customers are advised to consult with sales representatives before ordering.

The information, such as descriptions of function and application circuit examples, in this document are presented solely for the purpose of reference to show examples of operations and uses of FUJITSU MICROELECTRONICS device; FUJITSU MICROELECTRONICS does not warrant proper operation of the device with respect to use based on such information. When you develop equipment incorporating the device based on such information, you must assume any responsibility arising out of such use of the information.

FUJITSU MICROELECTRONICS assumes no liability for any damages whatsoever arising out of the use of the information.

Any information in this document, including descriptions of function and schematic diagrams, shall not be construed as license of the use or exercise of any intellectual property right, such as patent right or copyright, or any other right of FUJITSU MICROELECTRONICS or any third party or does FUJITSU MICROELECTRONICS warrant non-infringement of any third-party's intellectual property right or other right by using such information. FUJITSU MICROELECTRONICS assumes no liability for any infringement of the intellectual property rights or other rights of third parties which would result from the use of information contained herein.

The products described in this document are designed, developed and manufactured as contemplated for general use, including without limitation, ordinary industrial use, general office use, personal use, and household use, but are not designed, developed and manufactured as contemplated (1) for use accompanying fatal risks or dangers that, unless extremely high safety is secured, could have a serious effect to the public, and could lead directly to death, personal injury, severe physical damage or other loss (i.e., nuclear reaction control in nuclear facility, aircraft flight control, air traffic control, mass transport control, medical life support system, missile launch control in weapon system), or (2) for use requiring extremely high reliability (i.e., submersible repeater and artificial satellite).

Please note that FUJITSU MICROELECTRONICS will not be liable against you and/or any third party for any claims or damages arising in connection with above-mentioned uses of the products.

Any semiconductor devices have an inherent chance of failure. You must protect against injury, damage or loss from such failures by incorporating safety design measures into your facility and equipment such as redundancy, fire protection, and prevention of over-current levels and other abnormal operating conditions.

Exportation/release of any products described in this document may require necessary procedures in accordance with the regulations of the Foreign Exchange and Foreign Trade Control Law of Japan and/or US export control laws.

The company names and brand names herein are the trademarks or registered trademarks of their respective owners.

Edited Strategic Business Development Dept.