

SINGLE IDC CONTACT 12-18 AWG: 9177-500

General Information

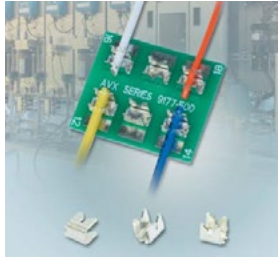

GENERAL DESCRIPTION

KYOCERA AVX's STRIPT™, insulation displacement naked contact technology provides cost effective, insulator-less, wire-to-board connection for discrete wire applications. Designed from the ground up to function just like a traditional insulated connector, these UL certified contacts have been industry proven for many years. This 9177-500 series has been designed to support the larger wire gauges from a robustness and current rating perspective. The optional cap provides a positive strain relief even in the harshest conditions and acts as the termination tool for severe vibration applications.

APPLICATIONS

- Industrial motor controls, drives & pumps
- Commercial building wiring and electrical systems
- Outdoor/Transportation lighting
- Solar and alternative energy

ELECTRICAL

- Current Rating: 15 Amps/Contact
- Voltage Rating: 600 VAC

ENVIRONMENTAL

- Operating Temperature: -40°C to +125°C

FEATURES AND BENEFITS

- Proven "gas tight" cold welded wire termination
- Redundant contact systems provides enhanced wire retention and high current carrying capabilities
- Cost effective STRIPT™ insulator-less contact system
- Optional termination cap provides additional strain relief for severe environments

MECHANICAL

- Cap Insulator Material: High Temperature Nylon: UL94V-0
- Contact Material: Phosphor Bronze
- Contact Plating: Pure tin over nickel
- Durability: 3 termination cycles

HOW TO ORDER – CONTACT OPTIONS

70	9177	001	5XX	006
Prefix	Series	No. of Ways 001 = 1	Description 591 = 12AWG Stranded and Solid 501 = 14AWG Stranded and Solid 512 = 16AWG Stranded and Solid 522 = 18AWG Stranded and Solid	Plating 006 = Pure Tin all over



Certification: UL File #E90723

HOW TO ORDER – CAP OPTIONS - SEE PAGE 5

SINGLE IDC CONTACT 12-18 AWG: 9177-500

Contact Detail

CONTACT DETAIL

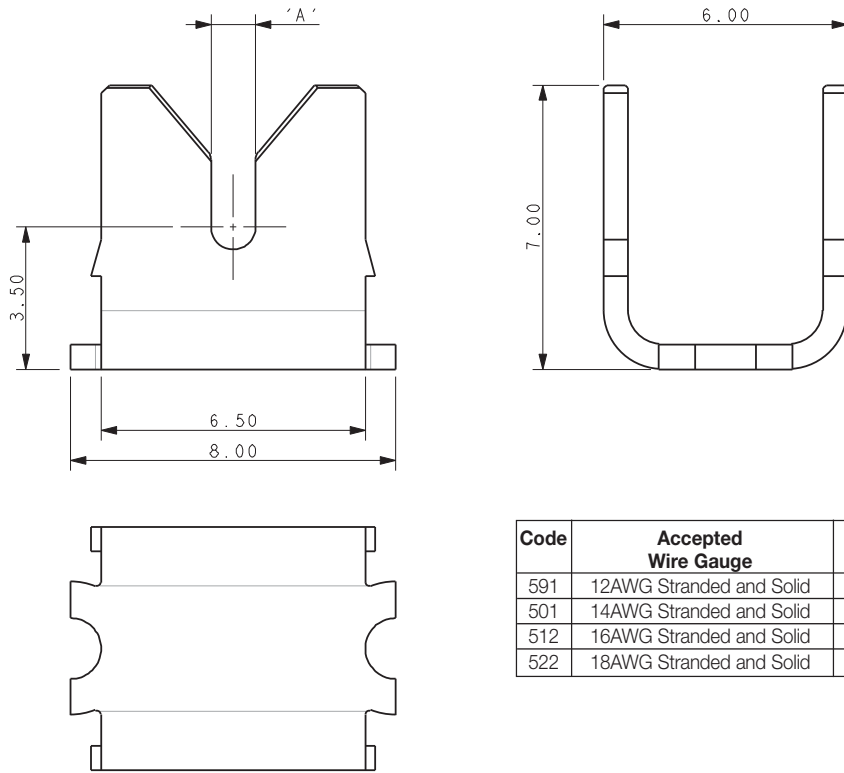

Code	Accepted Wire Gauge	A
591	12AWG Stranded and Solid	1.50
501	14AWG Stranded and Solid	1.10
512	16AWG Stranded and Solid	0.82
522	18AWG Stranded and Solid	0.72

NOTES:

- CONNECTOR FOR IDC WIRE TO BOARD CONNECTION.
- CONTACT MATERIAL: PHOSPHORE BRONZE.
- CONTACT PLATING: PURE TIN.
- CONTACTS DESIGNED TO ACCEPT BETWEEN 12 AND 18 GAUGE STANDED WIRE, SEE TABLE.
- ALL DIMENSIONS FOR REFERENCE UNLESS OTHERWISE STATED.
- FOR FULL PRODUCT SPECIFICATIONS REFER TO AVX SPECIFICATION 201-01-208 AND APPLICATION NOTES 201-01-209.
- SMT PCB LAYOUT, REFER TO PAGE 3.
- PACKING IN TAPE AND REEL, QUANTITY PER REEL 700.
- ASSEMBLY TOOLING ON PAGE 4.
- UL REFERENCE E90723 (US AND CANADA).

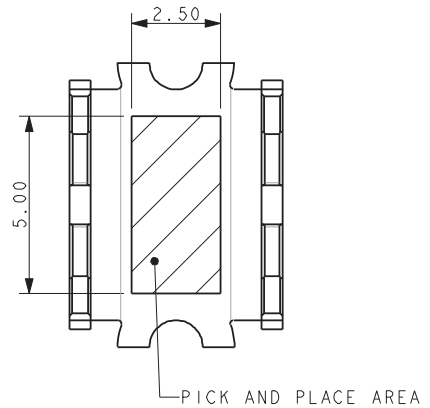

PACKING DETAILS

REEL QTY	700
LEADER	480MM
TRAILER	120MM

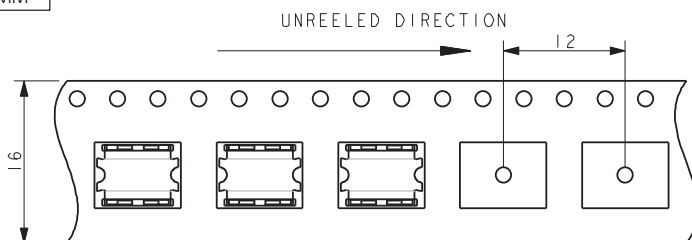
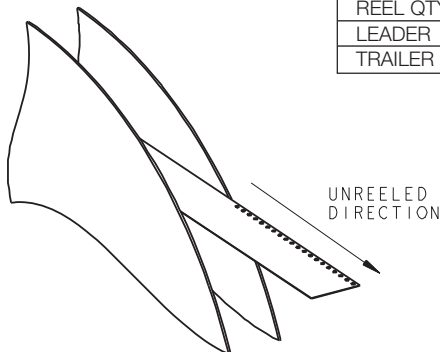

SINGLE IDC CONTACT 12-18 AWG: 9177-500

IDC Wire to Board Connector Single Contact

12-18 AWG IDC WIRE TO BOARD CONNECTOR SINGLE CONTACT

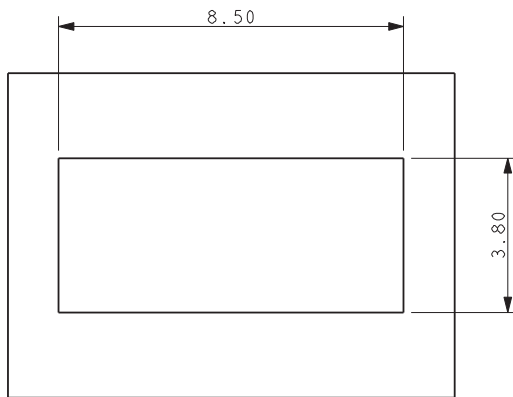

SUGGESTED PCB LAYOUT

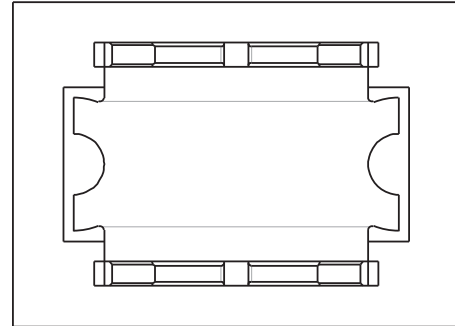

ORIENTATION OF CONTACT ON PAD

NOTES:

1. FOR FULL PRODUCT SPECIFICATION REFER TO AVX SPEC 201-01-208 AND 201-01-209
2. DIMENSIONS SHOWN ARE REFERENCE DIMENSIONS.
3. ASSEMBLY TOOLING ON PAGE 4.

SINGLE IDC CONTACT 12-18 AWG: 9177-500

Assembly Tooling

ASSEMBLY TOOLING

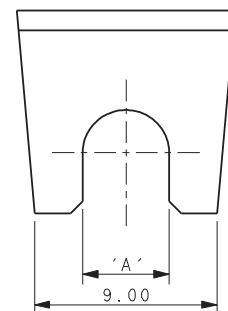
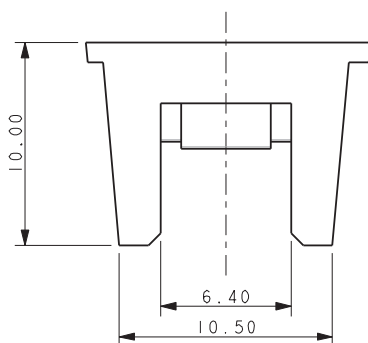
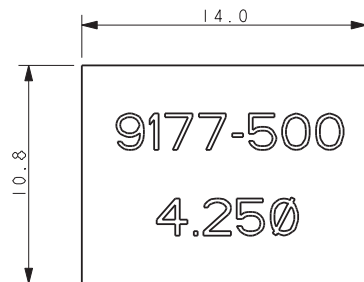

Wire Gauge	Max Insulation (Dimensions 'A')	Tool Number Metal Tool for High Volume	Tool Number Plastic Tool for Small to Medium Volume
12-18 AWG	Ø 4.25	06-9177-7020-01-001	06-9177-7022-01-001
12-18 AWG	Ø 3.50	06-9177-7020-02-001	06-9177-7022-02-001
12-18 AWG	Ø 2.75	06-9177-7020-03-001	06-9177-7022-03-001

NOTES:

1. ASSEMBLY TOOLING FOR CONTACTS 70-9177-001-5XX-006 ONLY.
2. MINIMUM AREA OF PCB TO BE KEPT CLEAR OF COMPONENTS. TRACKS PERMISSIBLE.
3. MAXIMUM COMPONENT HEIGHT 9.0MM IN THIS AREA.
4. REFER TO TABLE FOR CORRECT TOOL/WIRE COMBINATION.
5. REFER TO APPLICATION NOTE 201-01-209 FOR FURTHER INFORMATION.
6. DIMENSIONS FOR TOOL ARE REFERENCE DIMENSIONS.

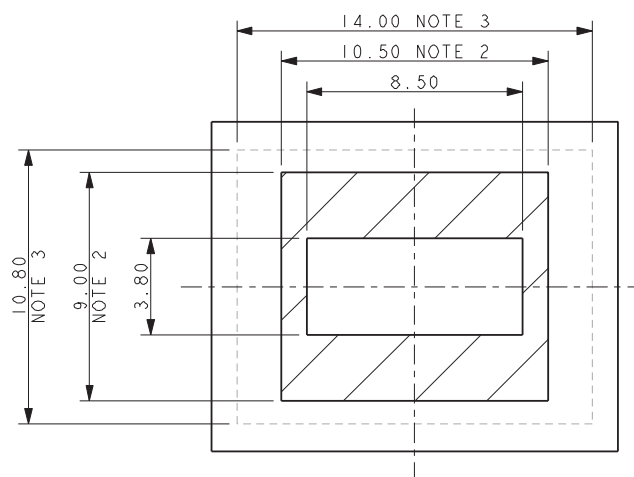

SINGLE IDC CONTACT 12-18 AWG: 9177-500

Cap Details

CAP DETAILS

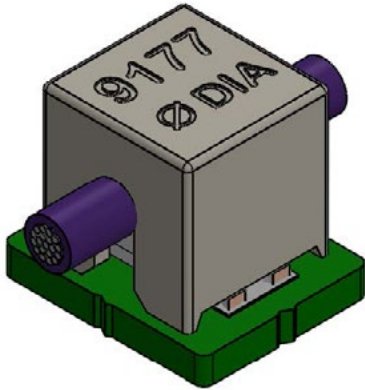

PART NUMBER	DIM. A	TEXT	WIRE	COLOR
60-9177-001-531-100	2.75	ø 3.1	12 AWG	WHITE (STANDARD)
60-9177-001-531-000				BLACK (SPECIAL ORDER)
60-9177-001-526-100	2.25	ø 2.6	14 AWG	WHITE (STANDARD)
60-9177-001-526-000				BLACK (SPECIAL ORDER)
60-9177-001-522-100	1.90	ø 2.2	16 AWG	WHITE (STANDARD)
60-9177-001-522-000				BLACK (SPECIAL ORDER)
60-9177-001-519-100	1.65	ø 1.9	18 SWG	WHITE (STANDARD)
60-9177-001-519-000				BLACK (SPECIAL ORDER)

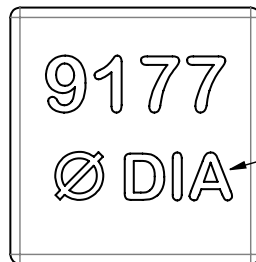

TEXT. SEE P.N. TABLE

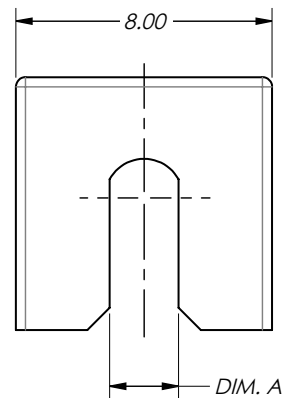
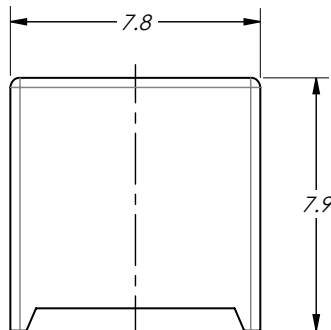
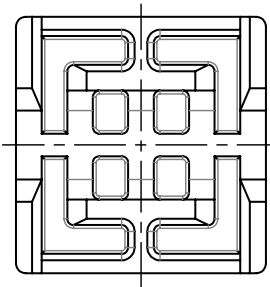

NOTES:

- CAP FOR TERMINATING WIRES TO 9177-500 SERIES CONTACTS.
- MATERIAL: HIGH TEMPERATURE NYLON; UL94V-0.
- FOR FULL PRODUCT SPECIFICATION, REFER TO KAVX PRODUCT SPEC 201-01-208 AND APPLICATION NOTES 201-01-124.
- PACKAGING TO BE BULK WITH 700 PARTS PER BAG.
- FOR INSTALLATION DETAILS, SEE DRAWING 70-9177-001-5XX-006S.
- PCB MUST BE CLEAR OF COMPONENTS ALLOWING CAP TO SEAT.