



CY39C605

Phase Dimmable PSR LED Driver IC for LED Lighting

Description

CY39C605 is a Primary Side Regulation (PSR) LED driver IC for LED lighting. Using the information of the primary peak current and the transformer-energy-zero time, it is able to deliver a well regulated current to the secondary side without using an opto-coupler in an isolated flyback topology. Operating in critical conduction mode, a smaller transformer is required. In addition, CY39C605 has a built-in phase dimmable circuit and can constitute the lighting system for phase dimming. It is most suitable for the general lighting applications, for example replacement of commercial and residential incandescent lamps.

Features

- PSR topology in an isolated flyback circuit
- High efficiency (>80% : without dimmer) and low EMI by detecting transformer zero energy
- TRAIC Dimmable LED lighting
- Highly reliable protection functions
 - Under voltage lock out (UVLO)
 - Over voltage protection (OVP)
 - Over current protection (OCP)
 - Short circuit protection (SCP)
 - Over temperature protection (OTP)
- Switching frequency setting : 30 kHz to 133 kHz
- Input voltage range VDD : 9V to 20V
- Input voltage for LED lighting applications : AC110V_{RMS}, AC230V_{RMS}
- Output power range for LED lighting applications : 5 W to 10 W
- Small Package : SOP-8 (3.9 mm × 5.05 mm × 1.75 mm [Max])

Applications

- Phase dimmable (Leading/Trailing) LED lighting
- LED lighting

Contents

1. Pin Assignment	3	8.6 Zero Voltage Switching Function	13
2. Pin Descriptions	3	8.7 Protection Functions	14
3. Block Diagram	4	9. I/O Pin Equivalent Circuit Diagram	15
4. Absolute Maximum Ratings	5	10. Application Examples	17
5. Recommended Operating Conditions	6	10.1 5W Non-isolated Dimming Application.....	17
6. Electrical Characteristics	7	11. Usage Precautions	22
7. Standard Characteristics	9	12. RoHS Compliance Information	22
8. Function Explanations	10	13. Ordering Information	22
8.1 LED Current Control by PSR (Primary Side Regulation)	10	14. Package Dimensions	23
8.2 Dimming Function	11	15. Major Changes	24
8.3 Power-On Sequence	12	Document History	25
8.4 Power-Off Sequence	13	Sales, Solutions, and Legal Information	26
8.5 I _{P_PEAK} Detection Function	13		

1. Pin Assignment

Figure 1-1. Pin Assignment

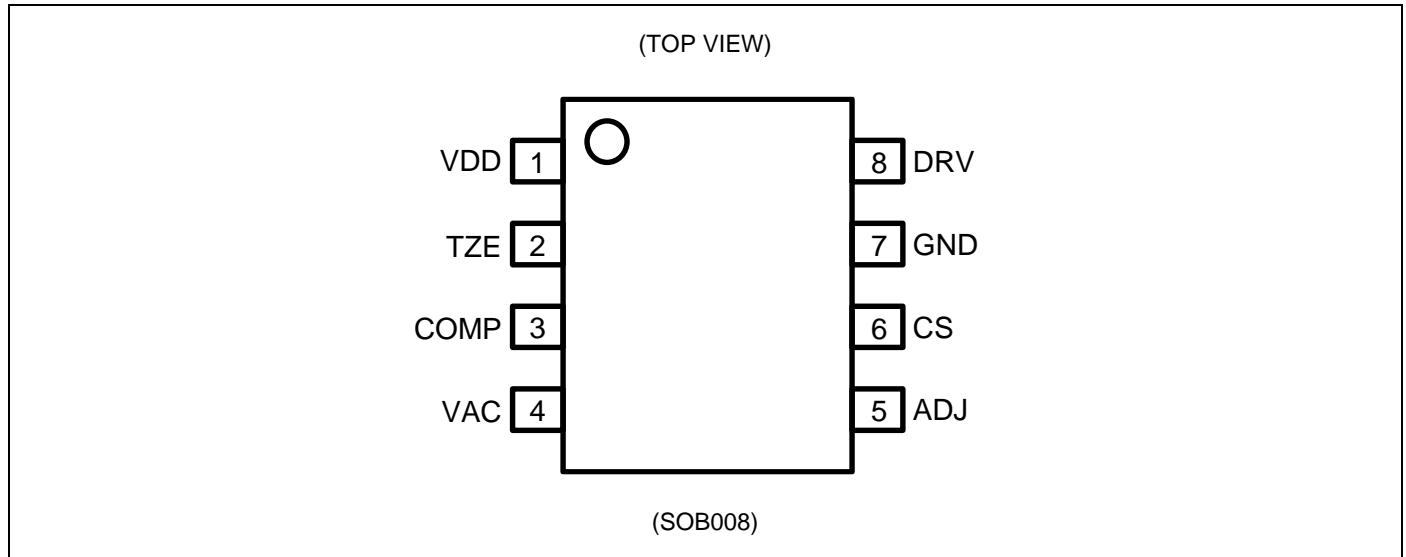

2. Pin Descriptions

Table 2-1. Pin Descriptions

Pin No.	Pin Name	I/O	Description
1	VDD	-	Power supply pin.
2	TZE	I	Transformer Zero Energy detecting pin.
3	COMP	O	External Capacitor connection pin for the compensation.
4	VAC	I	Phase dimming control pin.
5	ADJ	O	Pin for adjusting the switch-on timing.
6	CS	I	Pin for detecting peak current of transformer primary winding.
7	GND	-	Ground pin.
8	DRV	O	External MOSFET gate connection pin.

3. Block Diagram

Figure 3-1. Block Diagram (Isolated Flyback Application)

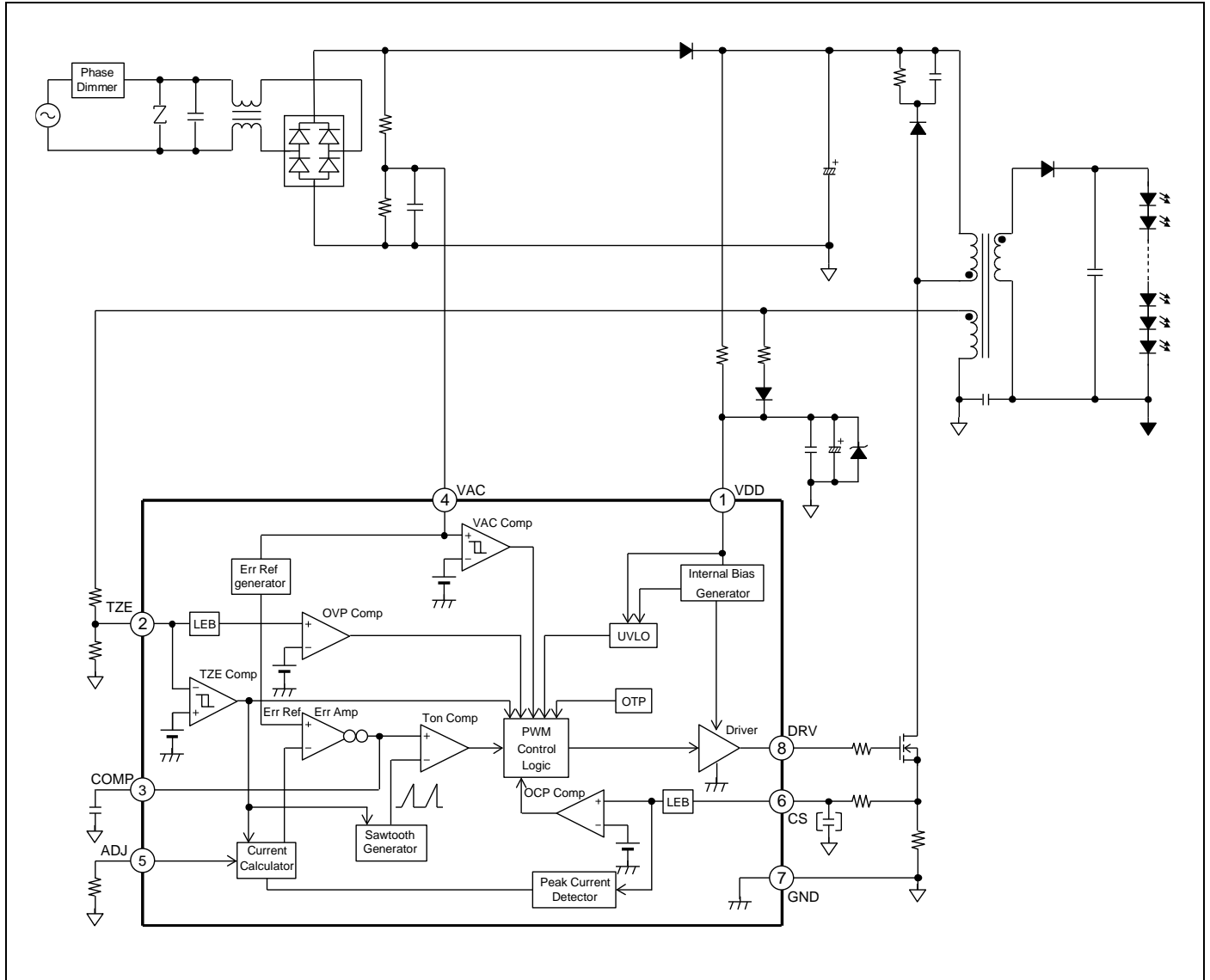

4. Absolute Maximum Ratings

Table 4-1. Absolute Maximum Rating

Parameter	Symbol	Condition	Rating		Unit
			Min	Max	
Power Supply Voltage	V _{VDD}	VDD pin	-0.3	+25	V
Input Voltage	V _{CS}	CS pin	-0.3	+6.0	V
	V _{TZE}	TZE pin	-0.3	+6.0	V
	V _{VAC}	VAC pin	-0.3	+6.0	V
Output Voltage	V _{DRV}	DRV pin	-0.3	+25	V
Output Current	I _{ADJ}	ADJ pin	-1	-	mA
	I _{DRV}	DRV pin DC level	-50	+50	mA
Power Dissipation	P _D	T _a ≤ +25°C	-	800 (*1)	mW
Storage temperature	T _{STG}	-	-55	+125	°C
ESD Voltage 1	V _{ESDH}	Human Body Model	-2000	+2000	V
ESD Voltage 2	V _{ESDC}	Charged Device Model	-1000	+1000	V

*1: The value when using two layers PCB.
Reference: θ_{ja} (wind speed 0m/s): +125°C/W

Figure 4-1. Power Dissipation

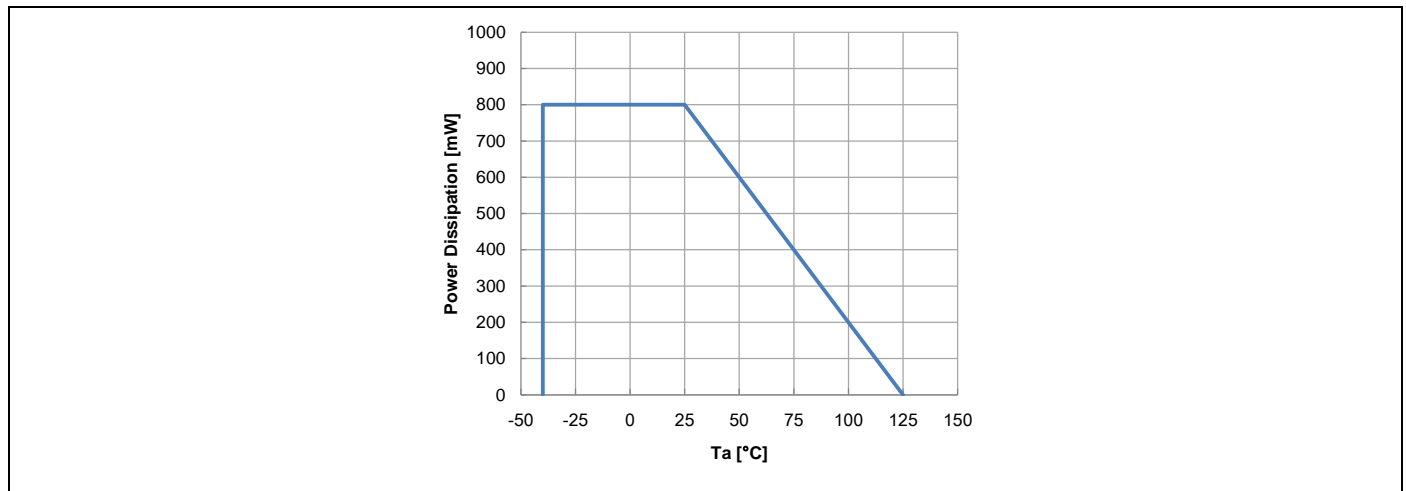

WARNING:

1. Semiconductor devices may be permanently damaged by application of stress (including, without limitation, voltage, current or temperature) in excess of absolute maximum ratings. Do not exceed any of these ratings.

5. Recommended Operating Conditions

Table 5-1. Recommended Operating Conditions

Parameter	Symbol	Condition	Value			Unit
			Min	Typ	Max	
VDD pin Input Voltage	VDD	VDD pin	9	-	20	V
VAC pin Input Voltage	V _{VAC}	VAC pin After UVLO release	0	-	5	V
VAC pin Input Current	I _{VAC}	VAC pin Before UVLO release	0	-	2.5	μA
TZE pin Resistance	R _{TZE}	TZE pin	50	-	200	kΩ
ADJ pin Resistance	R _{ADJ}	ADJ pin	9.3	-	185.5	kΩ
COMP pin Capacitance	C _{COMP}	COMP pin	-	0.01	-	μF
VDD pin Capacitance	C _{BP}	Set between VDD pin and GND pin	-	4.7	-	μF
Operating Junction Temperature	T _j	-	-40	-	+125	°C

WARNING:

1. The recommended operating conditions are required in order to ensure the normal operation of the semiconductor device. All of the device's electrical characteristics are warranted when the device is operated under these conditions.
2. Any use of semiconductor devices will be under their recommended operating condition.
3. Operation under any conditions other than these conditions may adversely affect reliability of device and could result in device failure.
4. No warranty is made with respect to any use, operating conditions or combinations not represented on this data sheet. If you are considering application under any conditions other than listed herein, please contact sales representatives beforehand.

6. Electrical Characteristics

Table 6-1 . Electrical Characteristics

 (Ta = +25°C, V_{VDD} = 12V)

Parameter		Symbol	Pin	Condition	Value			Unit
					Min	Typ	Max	
POWER SUPPLY CURRENT	Power supply current	I _{VDD(STATIC)}	VDD	V _{VDD} = 20V, V _{TZE} = 1V	-	3	3.6	mA
		I _{VDD(OPERATING)}	VDD	V _{VDD} = 20V, Q _g = 20 nC, f _{SW} = 133 kHz	-	5.6	-	mA
UVLO	UVLO Turn-on threshold voltage	V _{TH}	VDD	-	12.25	13	13.75	V
	UVLO Turn-off threshold voltage	V _{TL}	VDD	-	7.55	7.9	8.5	V
	Startup current	I _{START}	VDD	V _{VDD} = 7V	-	65	160	μA
TRANSFORMER ZERO ENERGY DETECTION	Zero energy threshold voltage	V _{TZETL}	TZE	TZE = "H" to "L"	-	20	-	mV
	Zero energy threshold voltage	V _{TZETH}	TZE	TZE = "L" to "H"	0.6	0.7	0.8	V
	TZE clamp voltage	V _{TZECLAMP}	TZE	I _{TZE} = -10 μA	-200	-160	-100	mV
	OVP threshold voltage	V _{TZEOVP}	TZE	-	4.15	4.3	4.45	V
	OVP blanking time	t _{OVPBLANK}	TZE	-	0.6	1	1.7	μs
	TZE input current	I _{TZE}	TZE	V _{TZE} = 5V	-1	-	+1	μA
COMPENSATION	Source current	I _{SO}	COMP	V _{COMP} = 2V, V _{CS} = 0V, V _{VAC} = 1.85V	-	-27	-	μA
	Trans conductance	gm	COMP	V _{COMP} = 2.5V, V _{CS} = 1V	-	96	-	μA/V
DIMMING	VAC input current	I _{VAC}	VAC	V _{VAC} = 5V	-0.1	-	+0.1	μA
	VACCOMP threshold voltage	V _{VACCOMPVTH}	VAC	-	135	150	165	mV
	VACCOMP hysteresis	V _{VACCOMP}	VAC	-	-	70	-	mV
ADJUSTMENT	ADJ voltage	V _{ADJ}	ADJ	-	1.81	1.85	1.89	V
	ADJ source current	I _{ADJ}	ADJ	V _{ADJ} = 0V	-650	-450	-250	μA
	ADJ time	T _{ADJ}	TZE DRV	T _{ADJ} (R _{ADJ} = 51 kΩ) - T _{ADJ} (R _{ADJ} = 9.1 kΩ)	490	550	610	ns
	Minimum switching period	T _{SW}	TZE DRV	-	6.75	7.5	8.25	μs

(Ta = +25°C, VDD = 12V)

Parameter	Symbol	Pin	Condition	Value			Unit	
				Min	Typ	Max		
CURRENT SENSE	OCP threshold voltage	V _{OCPH}	CS	-	1.9	2	2.1	V
	OCP delay time	t _{OCPDLY}	CS	-	-	400	500	ns
	CS input current	I _{CS}	CS	V _{CS} = 5V	-1	-	+1	μA
DRV	DRV high voltage	V _{DRVH}	DRV	VDD = 18V, I _{DRV} = -30 mA	7.6	9.4	-	V
	DRV low voltage	V _{DRVL}	DRV	VDD = 18V, I _{DRV} = 30 mA	-	130	260	mV
	Rise time	t _{RISE}	DRV	VDD = 18V, CLOAD = 1 nF	-	94	-	ns
	Fall time	t _{FALL}	DRV	VDD = 18V, CLOAD = 1 nF	-	16	-	ns
	Minimum on time	t _{ONMIN}	DRV	TZE trigger	300	500	700	ns
	Maximum on time	t _{ONMAX}	DRV	-	27	44	60	μs
	Minimum off time	t _{OFFMIN}	DRV	-	1	1.5	1.93	μs
	Maximum off time	t _{OFFMAX}	DRV	TZE = GND	270	320	370	μs
OTP	OTP threshold	T _{OTP}	-	T _j , temperature rising	-	+150	-	°C
	OTP hysteresis	T _{OTPHYS}	-	T _j , temperature falling, degrees below T _{OTP}	-	+25	-	°C

7. Standard Characteristics

Figure 7-1. Standard Characteristics

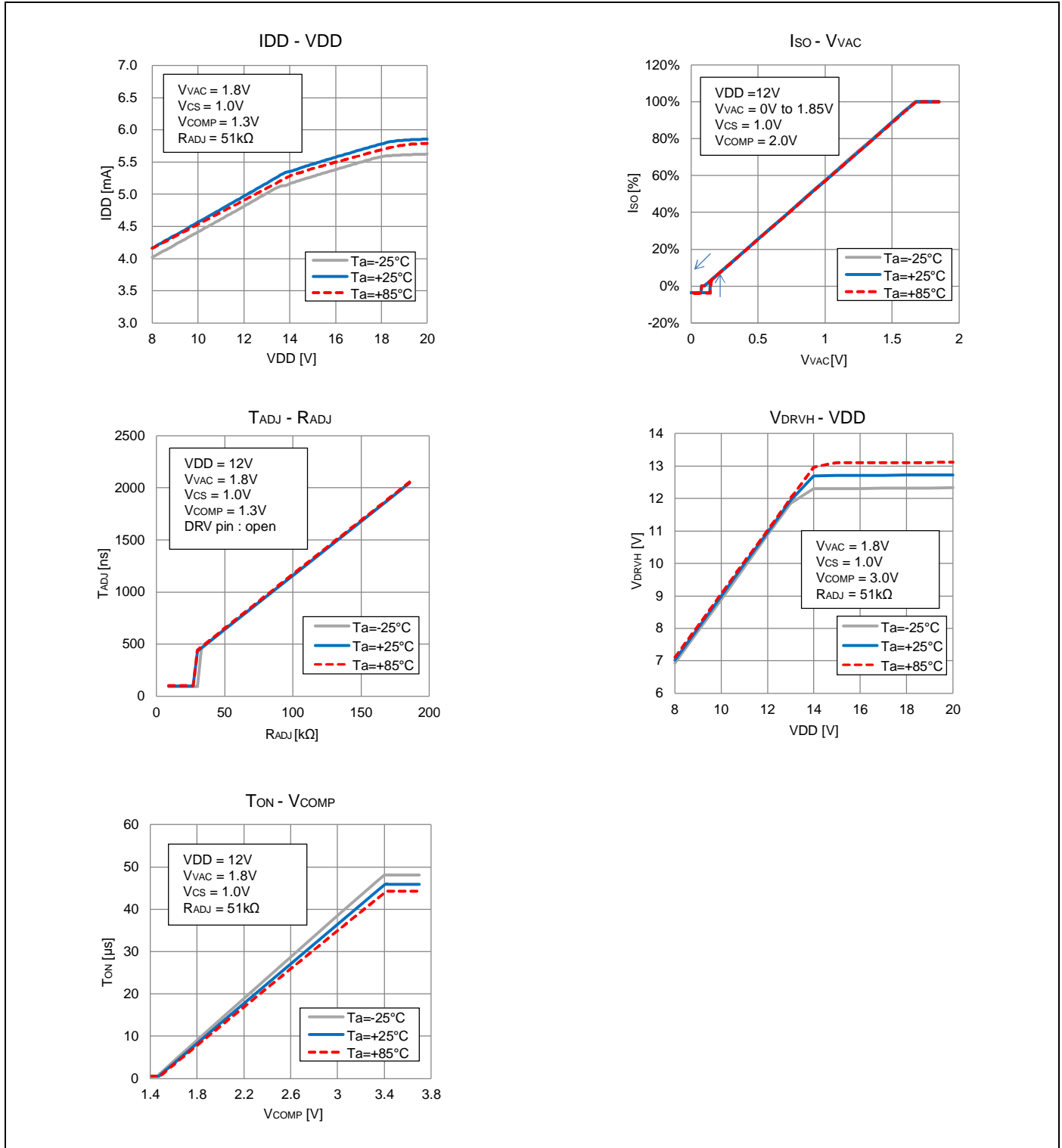

8. Function Explanations

8.1 LED Current Control by PSR (Primary Side Regulation)

CY39C605 regulates the average LED current (I_{LED}) by feeding back the information based on Primary Winding peak current (I_{P_PEAK}) and Secondary Winding energy discharge time (T_{DIS}) and switching period (T_{SW}). Figure 8-1 shows the operating waveform in steady state. I_P is Primary Winding current and I_S is Secondary Winding current. I_{LED} as an average current of the Secondary Winding is described by the following equation.

$$I_{LED} = \frac{1}{2} \times I_{S_PEAK} \times \frac{T_{DIS}}{T_{SW}}$$

Using I_{P_PEAK} and the transformer Secondary to Primary turns ratio (N_P/N_S), Secondary Winding peak current (I_{S_PEAK}) is described by the following equation.

$$I_{S_PEAK} = \frac{N_P}{N_S} \times I_{P_PEAK}$$

Therefore,

$$I_{LED} = \frac{1}{2} \times \frac{N_P}{N_S} \times I_{P_PEAK} \times \frac{T_{DIS}}{T_{SW}}$$

CY39C605 detects T_{DIS} by monitoring TZE pin and I_{P_PEAK} by monitoring CS pin. An internal Err Amp sinks gm current proportional to I_{P_PEAK} from COMP pin during T_{DIS} period. In steady state, since the average of the gm current is equal to internal reference current (I_{SO}), the voltage on COMP pin (V_{COMP}) is nearly constant.

$$I_{P_PEAK} \times R_{CS} \times gm \times T_{DIS} = I_{SO} \times T_{SW}$$

In above equation, gm is transconductance of the Err Amp and R_{CS} is a sense resistance. Eventually, I_{LED} can be calculated by the following equation.

$$I_{LED} = \frac{1}{2} \times \frac{N_P}{N_S} \times \frac{I_{SO}}{gm} \times \frac{1}{R_{CS}}$$

Figure 8-1. LED Current Control Waveform

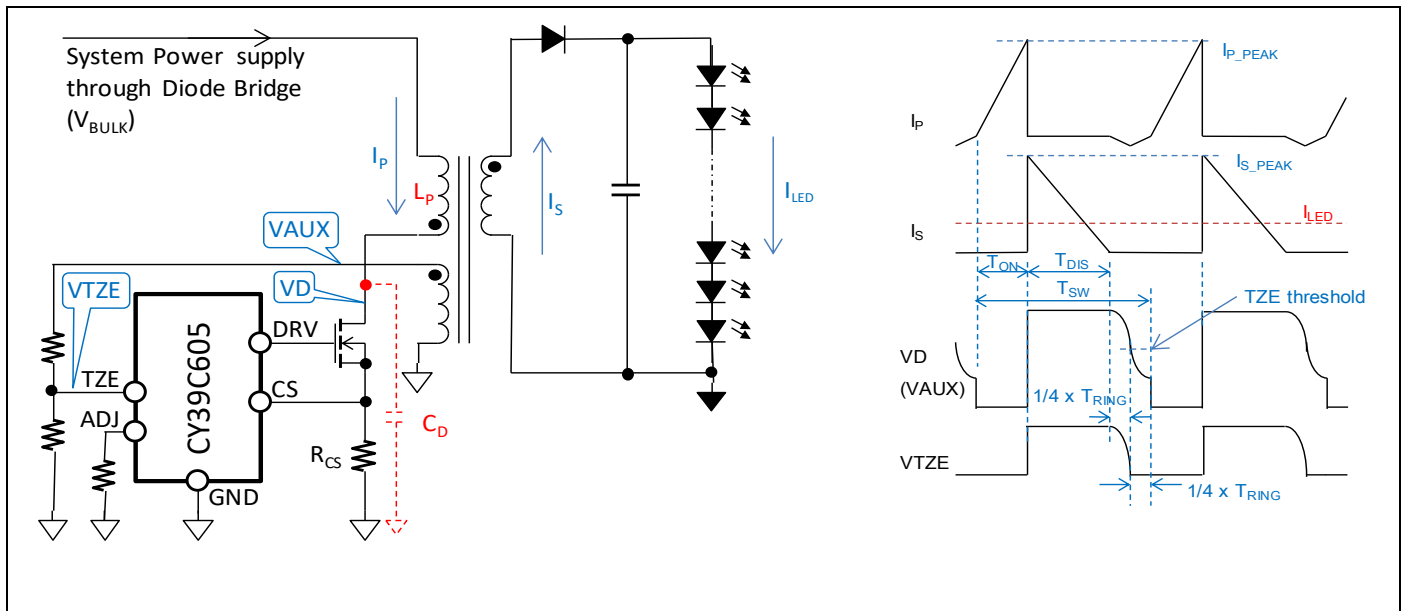

8.2 Dimming Function

CY39C605 has the built-in Phase dimmable circuit to control I_{LED} by changing a reference of Err Amp based on the input dimming control level on the VAC pin and realizes dimming. V_{BULK0} is divided and filtered into an analog voltage with RC network. It is possible to configurate phase dimmable system by inputting the voltage to the VAC pin.

Figure 8-2. VAC Pin Input Circuit

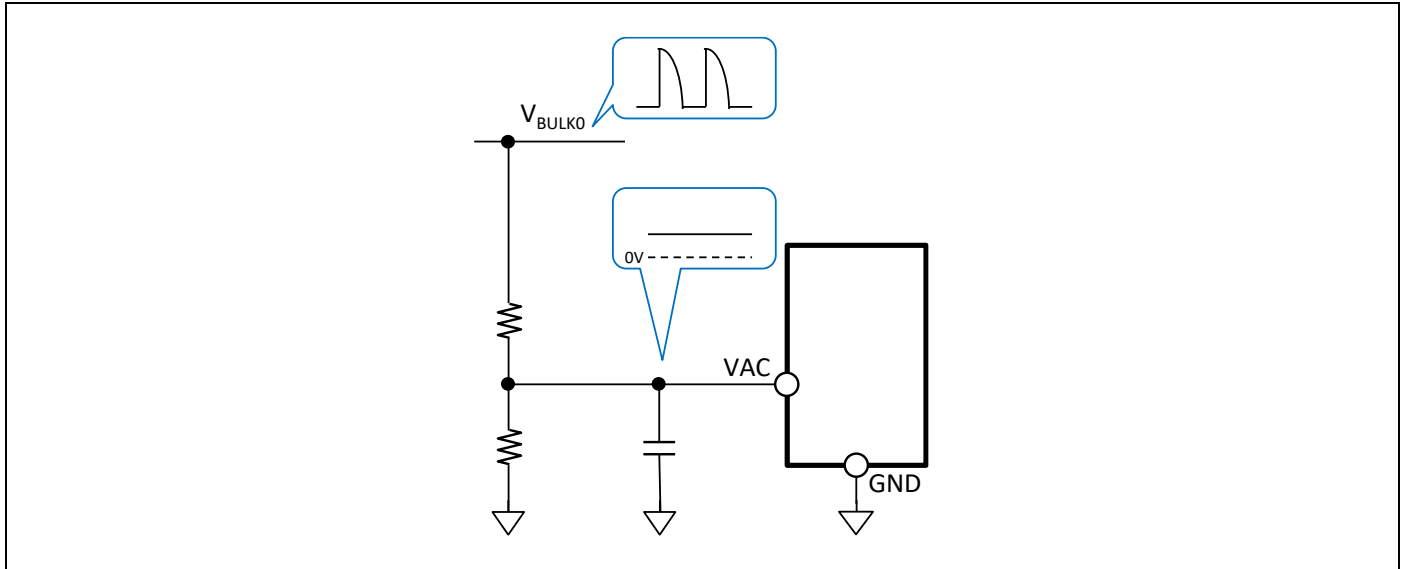

8.3 Power-On Sequence

When the AC line voltage is supplied, V_{BULK} is powered from the AC line through a diode bridge and a diode (D1) with charging a capacitor (C_{BULK}), and the VDD pin is charged from V_{BULK} through a start-up resistance (Rst). (Figure 8-3 red path)

When the VDD pin is charged up and the voltage on the VDD pin (V_{VDD}) rises above the UVLO threshold voltage, an internal Bias circuit starts operating, and CY39C605 starts the dimming control. After the UVLO is released, this device enables switching and is operating in a forced switching mode ($T_{ON} = 1.5 \mu s$, $T_{OFF} = 78 \mu s$ to $320 \mu s$). When the voltage on the TZE pin reaches the Zero energy threshold voltage ($V_{TZETH} = 0.7V$), CY39C605 enters normal operation mode. After the switching begins, the VDD pin is also charged from Auxiliary Winding through an external diode (DBIAS). (Figure 8-3 blue path)

During start-up period V_{VDD} is not supplied from Auxiliary Winding, because the LED voltage is low. V_{VDD} decreases gradually until the LED voltage rises above enough high that the Auxiliary Winding voltage can exceed V_{VDD} . In this period, if V_{VDD} falls below the UVLO threshold voltage, the switching stops. When the VDD pin is charged up again and V_{VDD} rises above the UVLO threshold voltage, CY39C605 restarts the switching. This device repeats above operation until the LED voltage rises above enough high. V_{VDD} becomes stable after that.

Figure 8-3. VDD Supply Path at Power-On

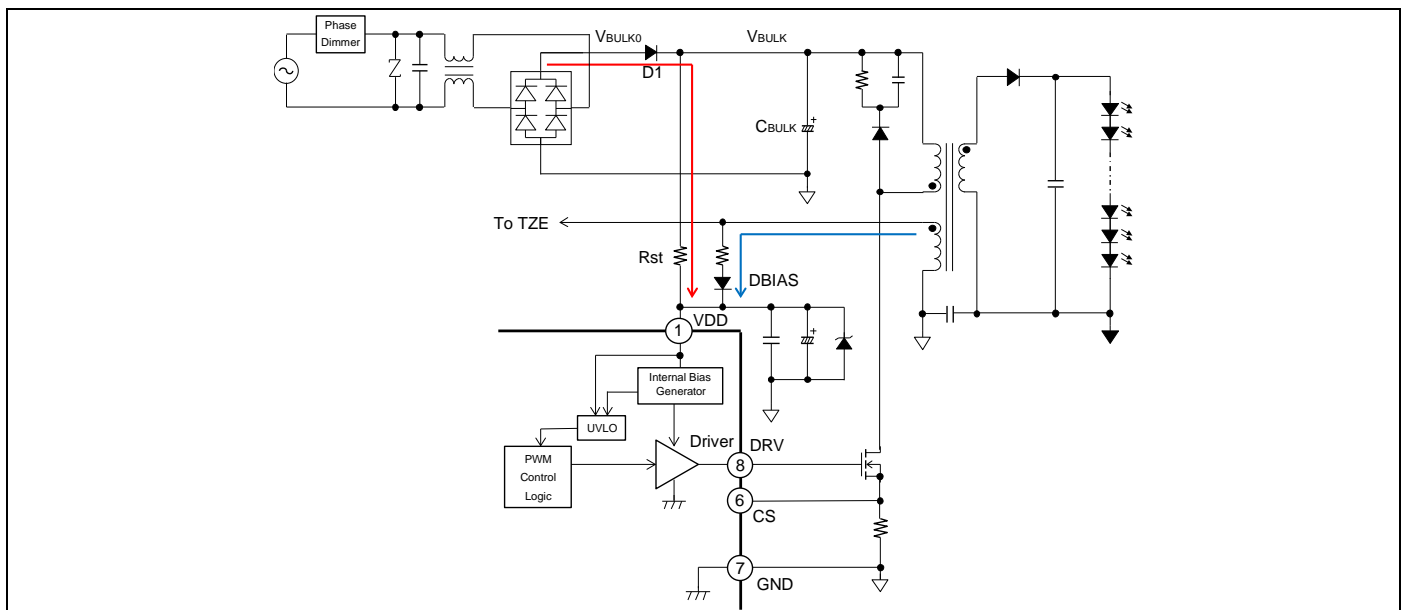
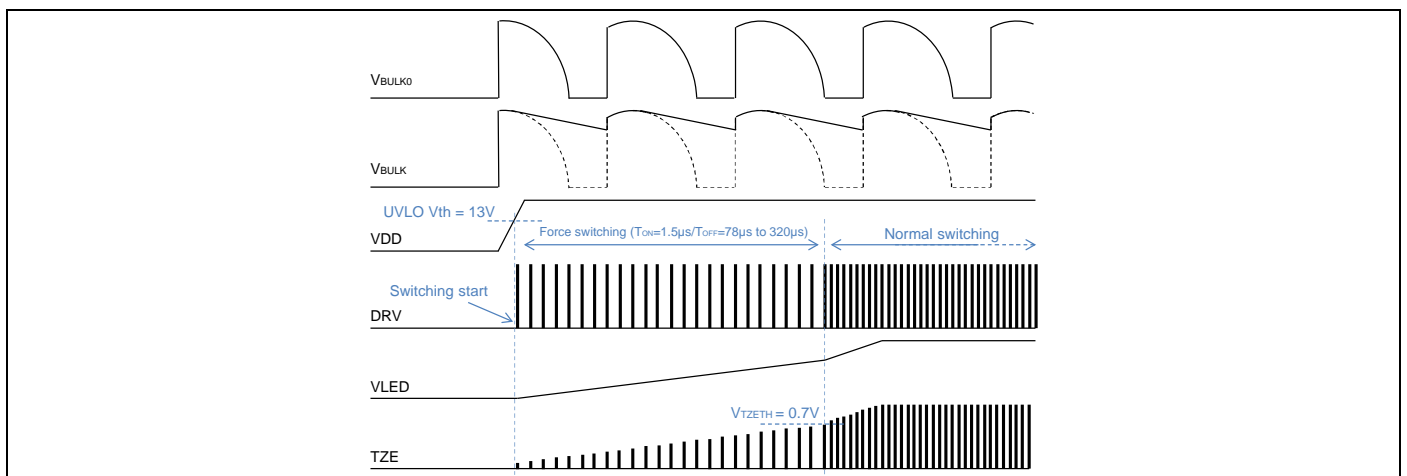

Figure 8-4. Power-On Waveform



8.4 Power-Off Sequence

After the AC line voltage is removed, V_{BULK} is discharged by switching operation. Since any Secondary Winding current does not flow, I_{LED} is supplied only from output capacitors and decreases gradually. V_{VDD} also decreases because there is no current supply from both Auxiliary Winding and V_{BULK} . When V_{VDD} falls below the UVLO threshold voltage, CY39C605 shuts down.

Figure 8-5. Power-Off Waveform

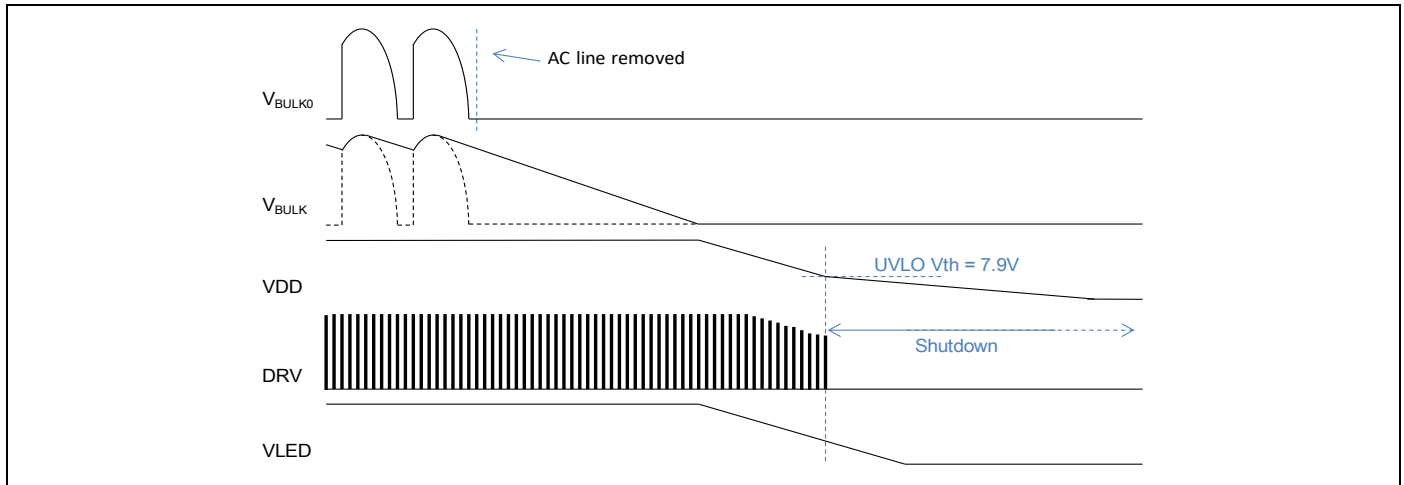

8.5 I_{P_PEAK} Detection Function

CY39C605 detects Primary Winding peak current (I_{P_PEAK}) of Transformer. I_{LED} is set by connecting a sense resistance (R_{CS}) between CS pin and GND pin. Maximum I_{P_PEAK} ($I_{P_PEAKMAX}$) limited by Over Current Protection (OCP) can also be set with the resistance.

Using the Secondary to Primary turns ratio (N_P/N_S) and I_{LED} , R_{CS} is set as the following equation (refer to 8.1)

$$R_{CS} = \frac{N_P}{N_S} \times \frac{0.14}{I_{LED}}$$

In addition, using the OCP threshold voltage (V_{OCPTH}) and R_{CS} , $I_{P_PEAKMAX}$ is calculated with the following equation.

$$I_{P_PEAKMAX} = \frac{V_{OCPTH}}{R_{CS}}$$

8.6 Zero Voltage Switching Function

CY39C605 has built-in zero voltage switching function to minimize switching loss of the external switching MOSFET. This device detects a zero crossing point through a resistor divider connected from TZE pin to Auxiliary Winding. A zero energy detection circuit detects a negative crossing point of the voltage on TZE pin to Zero energy threshold voltage (V_{TZETL}). On-timing of switching MOSFET is decided with waiting an adjustment time (t_{ADJ}) after the negative crossing occurs.

t_{ADJ} is set by connecting an external resistance (R_{ADJ}) between ADJ pin and GND pin. Using Primary Winding inductance (L_P) and the parasitic drain capacitor of switching MOSFET (C_D), t_{ADJ} is calculated with the following equation.

$$t_{ADJ} = \frac{\pi \sqrt{L_P \times C_D}}{2}$$

Using t_{ADJ} , R_{ADJ} is expressed by the following calculation.

$$R_{ADJ} [k\Omega] = 0.0927 \times t_{ADJ} [ns]$$

8.7 Protection Functions

Under Voltage Lockout Protection (UVLO)

The under voltage lockout protection (UVLO) prevents IC from a malfunction in the transient state during V_{VDD} startup and a malfunction caused by a momentary drop of V_{VDD} , and protects the system from destruction/deterioration. An UVLO comparator detects the voltage decrease below the UVLO threshold voltage on VDD pin, and then DRV pin is turned to “L” and the switching stops. CY39C605 automatically returns to normal operation mode when V_{VDD} increases above the UVLO threshold voltage.

Over Voltage Protection (OVP)

The over voltage protection (OVP) protects Secondary side components from an excessive voltage stress. If the LED is disconnected, the output voltage of Secondary Winding rises up. The output overvoltage can be detected by monitoring TZE pin. During Secondary Winding energy discharge time, V_{TZE} is proportional to V_{AUX} and the voltage of Secondary Winding (refer to 8.1). When V_{TZE} rises higher than the OVP threshold voltage for 3 continues switching cycles, DRV pin is turned to “L”, and the switching stops (latch off). When V_{VDD} drops below the UVLO threshold voltage, the latch is removed.

Over Current Protection (OCP)

The over current protection (OCP) prevents inductor or transformer from saturation. The drain current of the external switching MOSFET is limited by OCP. When the voltage on CS pin reaches the OCP threshold voltage, DRV pin is turned to “L” and the switching cycle ends. After zero crossing is detected on TZE pin again, DRV pin is turned to “H” and the next switching cycle begins.

Short Circuit Protection (SCP)

The short circuit protection (SCP) protects the transformer and the Secondary side diode from an excessive current stress. When the short circuit between LED terminals occurs, output voltage decreases. If the voltage on TZE pin falls below SCP threshold voltage, V_{COMP} is discharged and fixed at 1.5V and then the switching enters a low frequency mode. ($T_{ON} = 1.5 \mu s$ / $T_{OFF} = 78 \mu s$ to $320 \mu s$)

Over Temperature Protection (OTP)

The over temperature protection (OTP) protects IC from thermal destruction. When the junction temperature reaches $+150^{\circ}C$, DRV pin is turned to “L”, and the switching stops. It automatically returns to normal operation mode if the junction temperature falls back below $+125^{\circ}C$.

Table 8-1. Protection Functions Table

Function	PIN Operation			Detection Condition	Return Condition	Remarks
	DRV	COMP	ADJ			
Normal Operation	Active	Active	Active	-	-	-
Under Voltage Lockout Protection (UVLO)	L	L	L	$V_{DD} < 7.9V$	$V_{DD} > 13V$	Auto Restart
Over Voltage Protection (OVP)	L	1.5V fixed	Active	$TZE > 4.3V$	$V_{DD} < 7.9V$ → $V_{DD} > 13V$	Latch off
Over Current Protection (OCP)	L	Active	Active	$CS > 2V$	Cycle by cycle	Auto Restart
Short Circuit Protection (SCP)	Active	1.5V fixed	Active	$TZE (peak) < 0.7V$	$TZE (peak) > 0.7V$	Auto Restart
Over Temperature Protection (OTP)	L	1.5V fixed	Active	$T_j > +150^{\circ}C$	$T_j < +125^{\circ}C$	Auto Restart

9. I/O Pin Equivalent Circuit Diagram

Figure 9-1. I/O Pin Equivalent Circuit Diagram

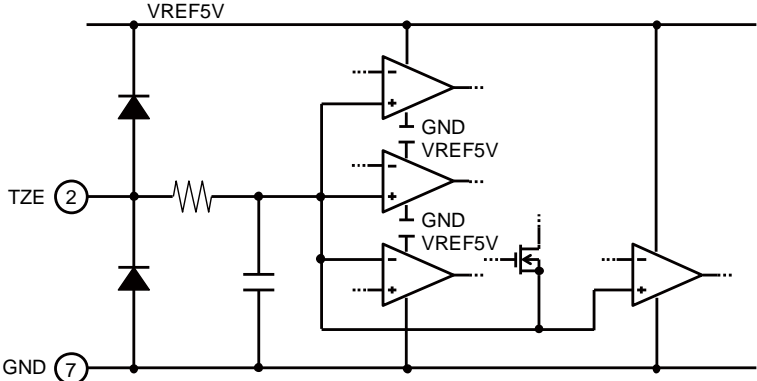
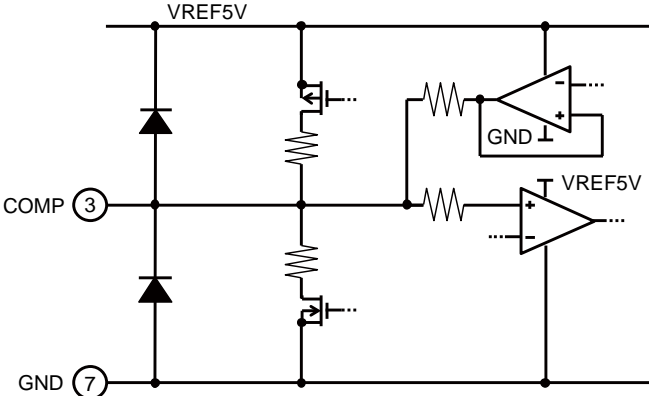
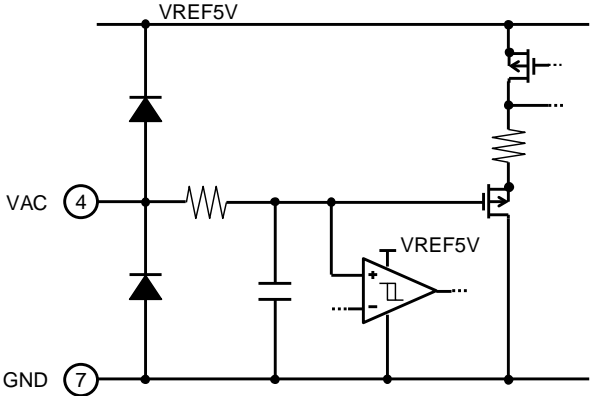
Pin No.	Pin Name	Equivalent Circuit Diagram
2	TZE	
3	COMP	
4	VAC	

Pin No.	Pin Name	Equivalent Circuit Diagram
5	ADJ	
6	CS	
8	DRV	

10. Application Examples

10.1 5W Non-isolated Dimming Application

Input: AC90V_{RMS}~110V_{RMS}, Output: 70mA/70V~76V, Ta = +25°C

Figure 10-1. 5W EVB Schematic

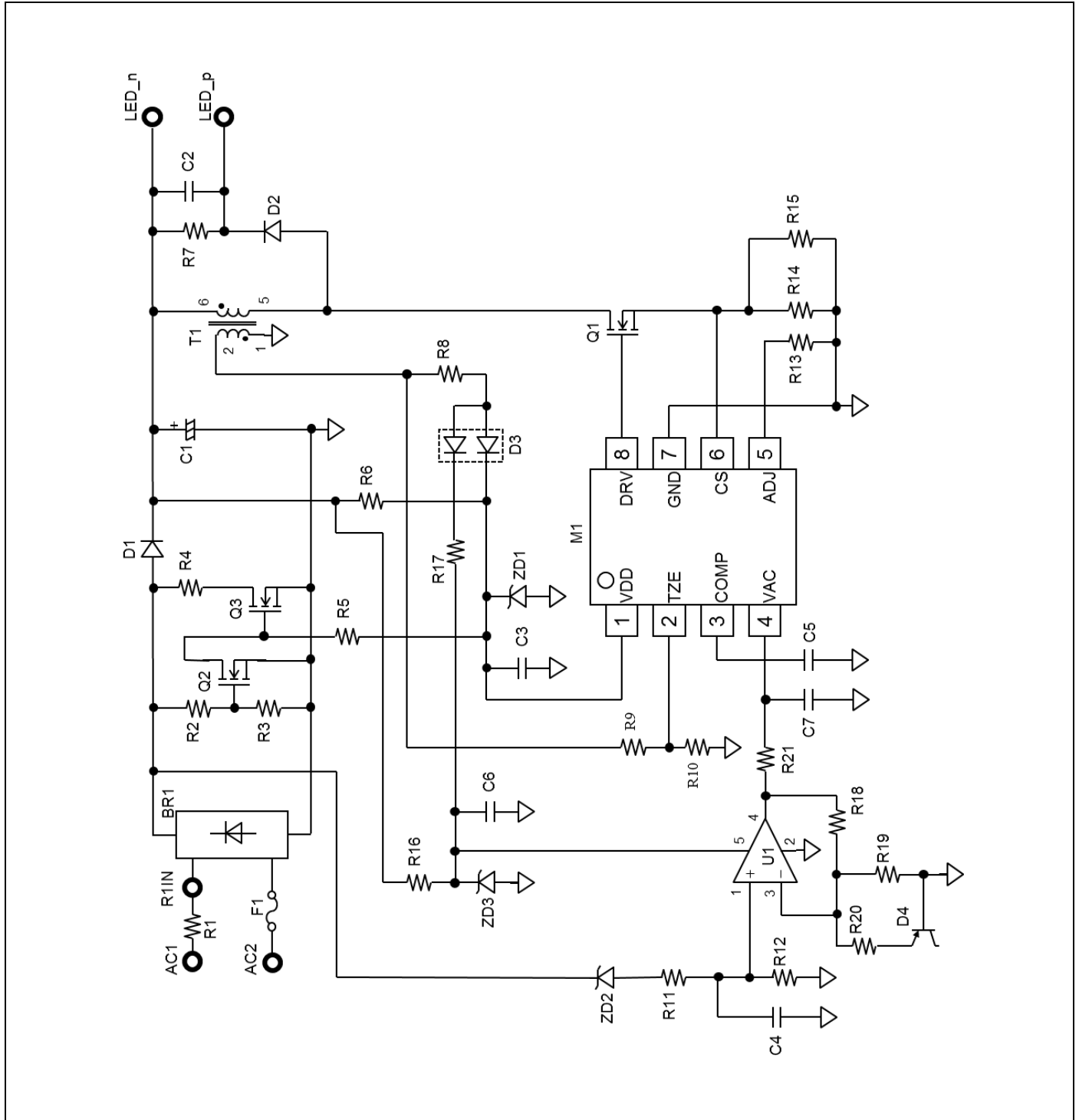
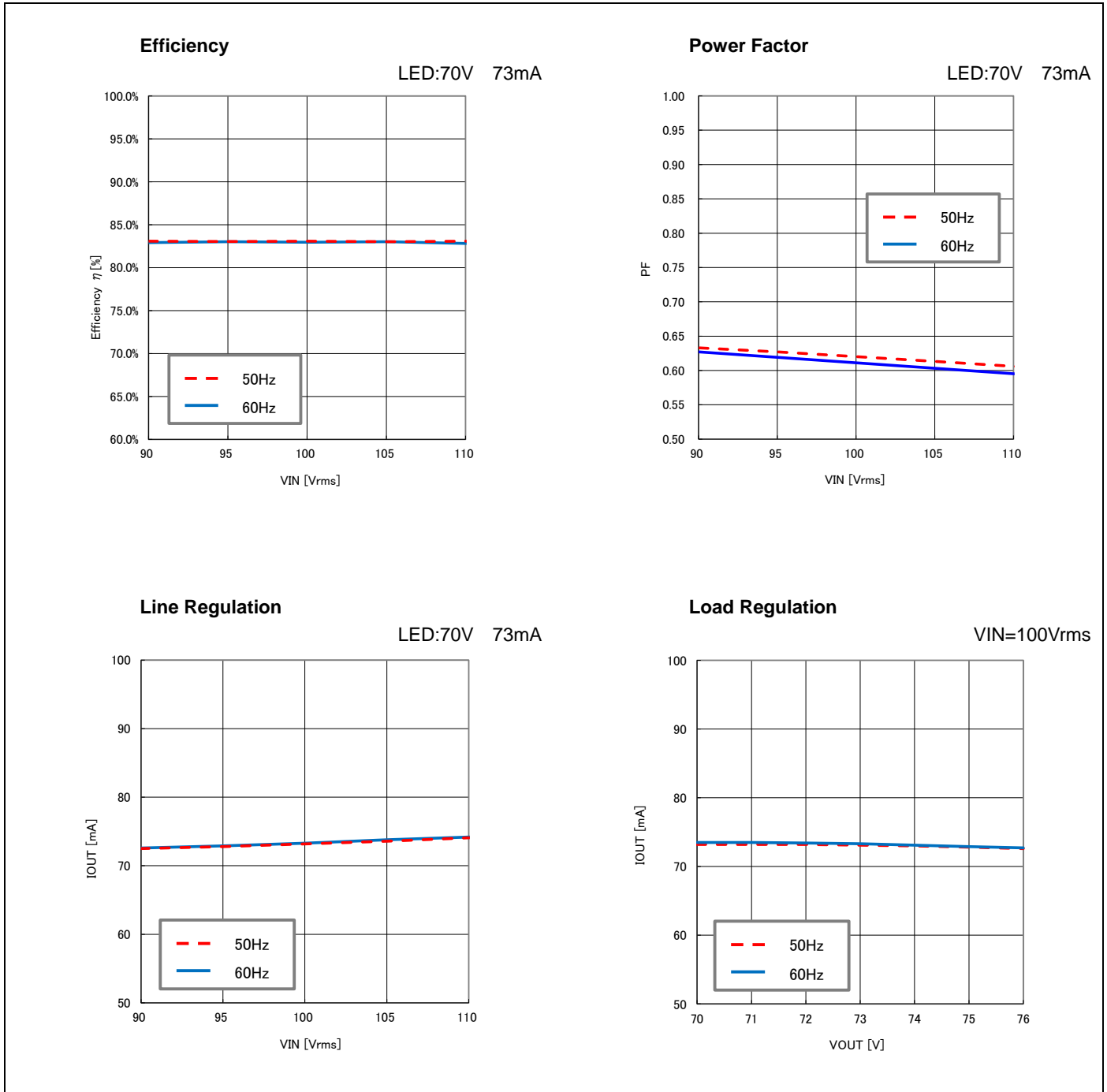

Table 10-1. 5W BOM List

No.	Component	Description	Part No.	Vendor
1	M1	LED driver IC SOP-8	CY39C605	Cypress
2	U1	Op-Amp, Low voltage Rail-to-Rail, 130µA, SOT-23-5	LMV321	TI
3	T1	Transformer, Lp = 550 µH Np/Na = 150/35	EE808	-
4	Q1	MosFET N-CH 600V 2.8A I-PAK	FQU5N60C	Fairchild
5	Q2	MosFET N-CH 60V 115mA SOT-23	2N7002	Fairchild
6	Q3	MosFET N-CH 600V 0.3A TO-92	FQN1N60C	Fairchild
7	BR1	Bridge Rectifiers, 0.5A, 600V, SOIC-4	MB6S	Fairchild
8	ZD1, ZD2	Diode, Zener, 18V, 500mW, SOD-123	MMSZ5248B	Fairchild
9	ZD3	Diode, Zener, 5.1V, 500mW, SOD-123	MMSZ4689	Fairchild
10	D1, D2	Diode, fast rectifier, 1A, 400V, SMA	ES1G	Fairchild
11	D3	Diode, 200mA, 200V, SOT-23	MMBD1405	Fairchild
12	D4	PNP Bipolar Transistor 12V 3A CPH3	CPH3106	On semiconductor
13	F1	Fuse, chip, 2A, AC/DC125V, 1206	3410.0035.01	Schurter Inc
14	C1	Capacitor, aluminum electrolytic, 8.2µF 200V φ8.0 × 11.0	200LLE8R2MEFC8X9	Rubycon
15	C2	Capacitor Ceramic 2.2µF 100V 1206	GRM31CR72A225KA73L	murata
16	C3	Capacitor Ceramic 4.7µF 35V 0603	-	-
17	C4, C7	Capacitor Ceramic 10µF 25V 0603	-	-
18	C5	Capacitor Ceramic 0.01µF 50V 0603	-	-
19	C6	Capacitor Ceramic 0.1µF 50V 0603	-	-
20	R1	Resistor, winding 10Ω 3W ±5%	-	-
21	R2, R11	Resistor, chip, 240kΩ, 1/10W, 0603	-	-
22	R3	Resistor, chip, 10kΩ, 1/10W, 0603	-	-
23	R4	Resistor, chip, 2kΩ, 1/4W, 1206	-	-
24	R5	Resistor, chip, 470kΩ, 1/10W, 0603	-	-
25	R6	Resistor, chip, 200kΩ 1/4W, 1206	-	-
26	R7	Resistor, chip, 100kΩ, 1/10W, 0603	-	-
27	R8	Resistor, chip, 10Ω, 1/10W, 0603	-	-
28	R9	Resistor, chip, 110kΩ, 1/10W, 0603	-	-
29	R10	Resistor, chip, 30kΩ, 1/10W, 0603	-	-
30	R12	Resistor, chip, 3.0kΩ, 1/10W, 0603	-	-
31	R13	Resistor, chip, 24kΩ, 1/10W, 0603	-	-
32	R14	Resistor, chip, 3.3Ω, 1/10W, 0603	-	-
33	R15	Resistor, chip, 4.7Ω, 1/10W, 0603	-	-
34	R16	Resistor, chip, 150kΩ 1/4W, 1206	-	-
35	R17	Resistor, chip, 5.1kΩ, 1/10W, 0603	-	-
36	R18	Resistor, chip, 36kΩ, 1/10W, 0603	-	-
37	R19	Resistor, chip, 150kΩ, 1/10W, 0603	-	-
38	R20	Resistor, chip, 3.3kΩ, 1/10W, 0603	-	-
39	R21	Resistor, chip, 1kΩ, 1/10W, 0603	-	-

TI : Texas Instruments Incorporated
 Fairchild : Fairchild Semiconductor International, Inc.
 On Semiconductor : ON Semiconductor
 Schurter Inc : Schurter Holding AG
 Rubycon : Rubycon Corporation
 muRata : Murata Manufacturing Co., Ltd.

Figure 10-2. 5W Reference Data

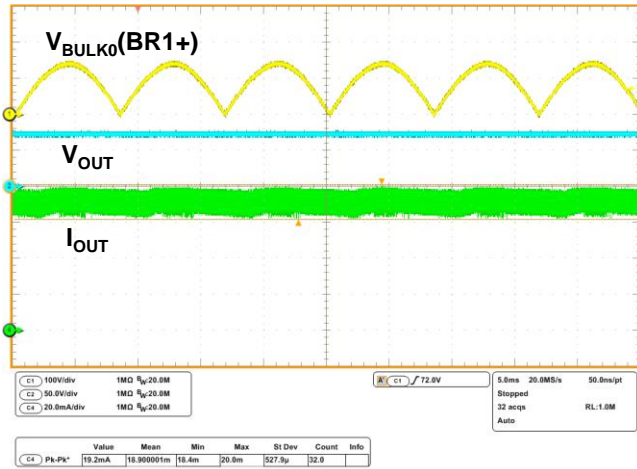
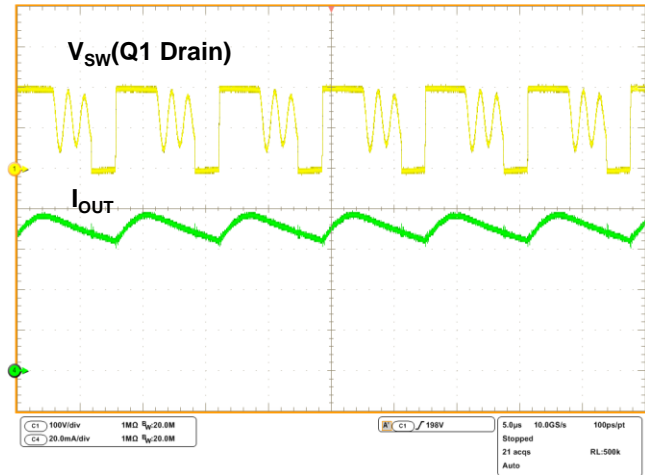
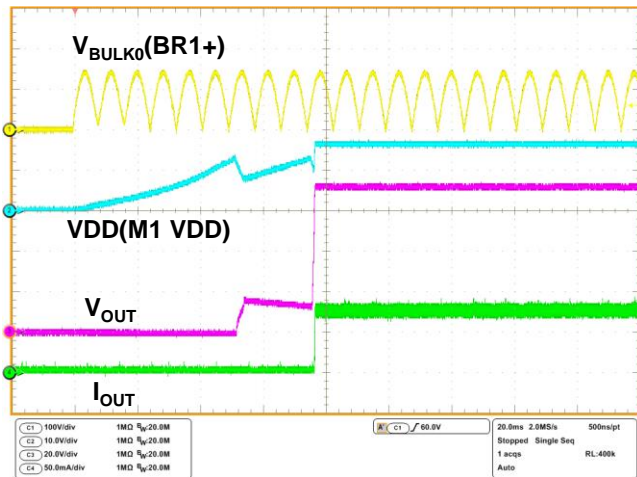
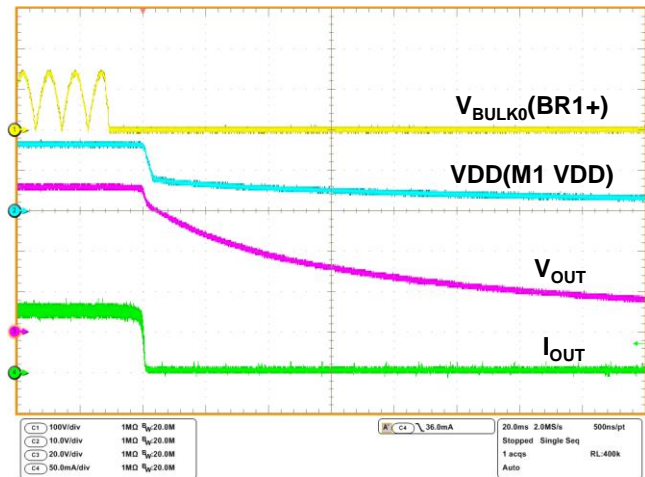

Output Ripple Waveform
 $V_{IN}=100V_{RMS} / 60Hz$
 LED:70V 73mA

Switching Waveform
 $V_{IN}=100V_{RMS} / 60Hz$
 LED:70V 73mA

Turn-On Waveform
 $V_{IN}=100V_{RMS} / 60Hz$
 LED:70V 73mA

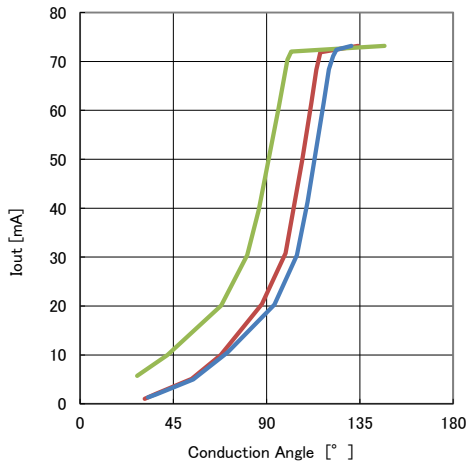
Turn-Off Waveform
 $V_{IN}=100V_{RMS} / 60Hz$
 LED:70V 73mA

Dimming Curve

$V_{IN}=100V_{RMS} / 50Hz$
LED:70V 73mA



— : DVCL-123P-JA
— : WTC 57521
— : WDG9001

Dimming Curve

$V_{IN}=100V_{RMS} / 60Hz$
LED:70V 73mA

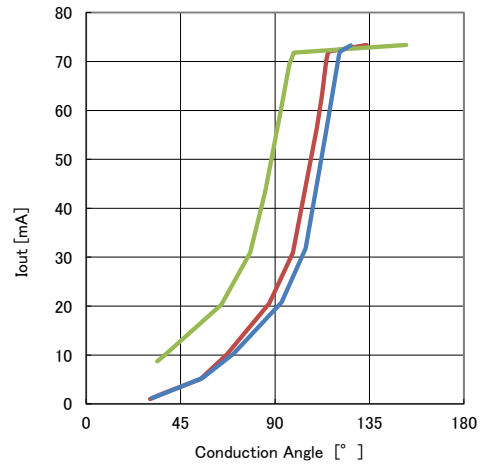

— : DVCL-123P-JA
— : WTC 57521
— : WDG9001

Dimmer		Input Condition	Type	Minimum	Minimum	Maximum	Maximum
Vendor	Parts Name			Angle (°)	I_{OUT} (mA)	Angle (°)	I_{OUT} (mA)
LUTRON	DVCL-123P-JA	$V_{IN}=100V_{rms}$ 50Hz (Japan Dimmer)	Leading Edge	32.8	1.3	130.9	73.2
Panasonic	WTC 57521			31.1	1.0	134.1	73.2
TOSHIBA	WDG9001		Trailing Edge	27.5	5.7	146.9	73.2
LUTRON	DVCL-123P-JA	$V_{IN}=100V_{rms}$ 60Hz (Japan Dimmer)	Leading Edge	31.3	1.2	126.1	73.3
Panasonic	WTC 57521			30.5	1.0	133.7	73.4
TOSHIBA	WDG9001		Trailing Edge	33.9	8.7	152.5	73.4

Total Harmonic Distortion(THD)

LED:70V 73mA

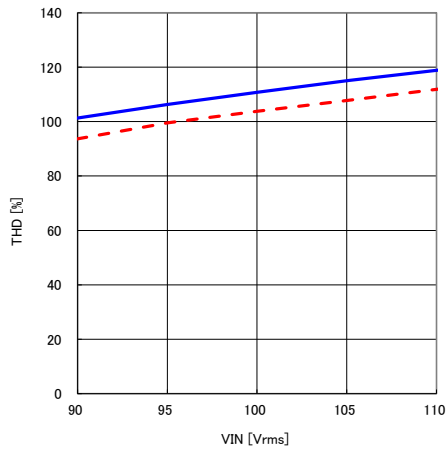

11. Usage Precautions

Do not configure the IC over the maximum ratings.

If the IC is used over the maximum ratings, the LSI may be permanently damaged.

It is preferable for the device to normally operate within the recommended usage conditions. Usage outside of these conditions can have an adverse effect on the reliability of the LSI.

Use the device within the recommended operating conditions.

The recommended values guarantee the normal LSI operation under the recommended operating conditions.

The electrical ratings are guaranteed when the device is used within the recommended operating conditions and under the conditions stated for each item.

Printed circuit board ground lines should be set up with consideration for common impedance.

Take appropriate measures against static electricity.

- Containers for semiconductor materials should have anti-static protection or be made of conductive material.
- After mounting, printed circuit boards should be stored and shipped in conductive bags or containers.
- Work platforms, tools, and instruments should be properly grounded.
- Working personnel should be grounded with resistance of 250 kΩ to 1 MΩ in serial between body and ground.

Do not apply negative voltages.

The use of negative voltages below - 0.3 V may make the parasitic transistor activated to the LSI, and can cause malfunctions.

12. RoHS Compliance Information

This product has observed the standard of lead, cadmium, mercury, Hexavalent chromium, polybrominated biphenyls (PBB), and polybrominated diphenyl ethers (PBDE).

13. Ordering Information

Table 13-1. Ordering Information

Part Number	Package	Shipping Form
CY39C605PNF-G-JNEFE1	8-pin plastic SOP (SOB008)	Emboss
CY39C605PNF-G-JNE1		Tube

14. Package Dimensions

Package Code: SOB008

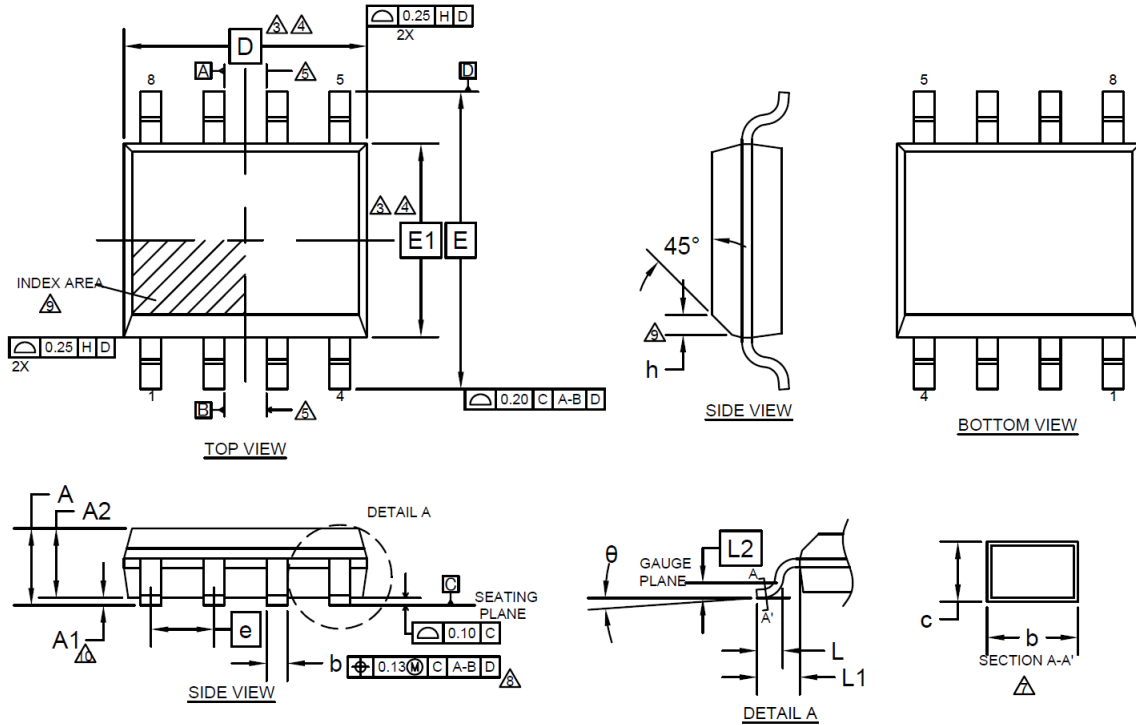

SYMBOL	DIMENSIONS		
	MIN.	NOM.	MAX.
A	—	—	1.75
A1	0.05	—	0.25
A2	1.30	1.40	1.50
D	5.05 BSC.		
E	6.00 BSC.		
E1	3.90 BSC		
θ	0°	—	8°
c	0.15	—	0.25
b	0.36	0.44	0.52
L	0.45	0.60	0.75
L 1	1.05 REF		
L 2	0.25 BSC		
e	1.27 BSC.		
h	0.40 BSC.		

NOTES

1. ALL DIMENSIONS ARE IN MILLIMETER.
2. DIMENSIONING AND TOLERANCING PER ASME Y14.5M-1994.
3. DIMENSIONING D INCLUDE MOLD FLASH, DIMENSIONING E1 DOES NOT INCLUDE INTERLEAD FLASH OR PROTRUSION. INTERLEAD FLASH OR PROTRUSIONS SHALL NOT EXCEED 0.025 mm PER SIDE. D and E1 DIMENSION ARE DETERMINED AT DATUM H.
4. THE PACKAGE TOP MAY BE SMALLER THAN THE PACKAGE BOTTOM. DIMENSIONING D and E1 ARE DETERMINED AT THE OUTERMOST EXTREMES OF THE PLASTIC BODY EXCLUSIVE OF MOLD FLASH, THE BAR BURRS, GATE BURRS AND INTERLEAD FLASH, BUT INCLUDING ANY MISMATCH BETWEEN THE TOP AND BOTTOM OF THE PLASTIC BODY.
5. DATUMS A & B TO BE DETERMINED AT DATUM H.
6. "N" IS THE MAXIMUM NUMBER OF TERMINAL POSITIONS FOR THE SPECIFIED PACKAGE LENGTH.
7. THE DIMENSION APPLY TO THE FLAT SECTION OF THE LEAD BETWEEN 0.10 mm TO 0.25mm FROM THE LEAD TIP.
8. DIMENSION "b" DOES NOT INCLUDE THE DAMBAR PROTRUSION. ALLOWABLE DAMBAR PROTRUSION SHALL BE 0.10mm TOTAL IN EXCESS OF THE "b" DIMENSION AT MAXIMUM MATERIAL CONDITION. THE DAMBAR MAY NOT BE LOCATED ON THE LOWER RADIUS OF THE FOOT.
9. THIS CHAMFER FEATURE IS OPTIONAL. LF IT IS NOT PRESENT, THEN A PIN 1 IDENTIFIER MUST BE LOCATED WITHIN THE INDEX AREA INDICATED
10. "A1" IS DEFINED AS THE VERTICAL DISTANCE FROM THE SEATING PLANE TO THE LOWEST POINT ON THE PACKAGE BODY EXCLUDING THE LID AND OR THERMAL ENHANCEMENT ON CAVITY DOWN PACKAGE CONFIGURATIONS.
11. JEDEC SPECIFICATION NO. REF : N/A

002-15856 Rev. **

15. Major Changes

Spancion Publication Number: MB39C605-DS405-00017

Page	Section	Descriptions
Revision 1.0		
-	-	Initial release
Revision 2.0		
16	11.6 Zero Voltage Switching Function	Corrected the R_{ADJ} formula
20	13. Application Examples	Added Application Examples
26	15. Ordering Information	Added Shipping in Table 15-1
-	-	Rewrote entire document for improving the ease of understanding (the original intentions are remained unchanged).
Revision 3.0		
8	7. Absolute Maximum Ratings	Removed ESD Voltage (Machine Model) from Table 7-1
-	Labeling Sample	Removed section of Labeling Sample
28	17. Recommended mounting condition [JEDEC Level3] Lead Free	Changed Recommended Condition from three conditions to one condition "JEDEC LEVEL3"

NOTE: Please see "Document History" about later revised information.

Document History

Document Title: CY39C605 Phase Dimmable PSR LED Driver IC for LED Lighting
 Document Number: 002-08444

Revision	ECN	Orig. of Change	Submission Date	Description of Change
**	-	TOYO	02/20/2015	Migrated to Cypress and assigned document number 002-08444. No change to document contents or format.
*A	5211375	TOYO	04/12/2016	Updated to Cypress format.
*B	5742349	HIXT	05/22/2017	Updated Pin Assignment : Change the package name from FPT-8P-M02 to SOB008 Added RoHS Compliance Information Updated Ordering Information : Change the package name from FPT-8P-M02 to SOB008 Deleted "Marking Format" Deleted "Recommended Mounting Condition [JEDEC Level3] Lead Free" Updated Package Dimensions : Updated to Cypress format
*C	6437385	ATTS	01/10/2019	Changed part number to CY39C605 Remove Easy Designsim comments

Sales, Solutions, and Legal Information

Worldwide Sales and Design Support

Cypress maintains a worldwide network of offices, solution centers, manufacturer's representatives, and distributors. To find the office closest to you, visit us at [Cypress Locations](#).

Products

Arm® Cortex® Microcontrollers	cypress.com/arm
Automotive	cypress.com/automotive
Clocks & Buffers	cypress.com/clocks
Interface	cypress.com/interface
Internet of Things	cypress.com/iot
Memory	cypress.com/memory
Microcontrollers	cypress.com/mcu
PSoC	cypress.com/psoc
Power Management ICs	cypress.com/pmic
Touch Sensing	cypress.com/touch
USB Controllers	cypress.com/usb
Wireless Connectivity	cypress.com/wireless

PSoC® Solutions

[PSoC 1](#) | [PSoC 3](#) | [PSoC 4](#) | [PSoC 5LP](#) | [PSoC 6 MCU](#)

Cypress Developer Community

[Community](#) | [Projects](#) | [Videos](#) | [Blogs](#) | [Training](#) | [Components](#)

Technical Support

cypress.com/support

Arm and Cortex are registered trademarks of Arm Limited (or its subsidiaries) in the US and/or elsewhere.

© Cypress Semiconductor Corporation, 2014-2019. This document is the property of Cypress Semiconductor Corporation and its subsidiaries, including Spansion LLC ("Cypress"). This document, including any software or firmware included or referenced in this document ("Software"), is owned by Cypress under the intellectual property laws and treaties of the United States and other countries worldwide. Cypress reserves all rights under such laws and treaties and does not, except as specifically stated in this paragraph, grant any license under its patents, copyrights, trademarks, or other intellectual property rights. If the Software is not accompanied by a license agreement and you do not otherwise have a written agreement with Cypress governing the use of the Software, then Cypress hereby grants you a personal, non-exclusive, nontransferable license (without the right to sublicense) (1) under its copyright rights in the Software (a) for Software provided in source code form, to modify and reproduce the Software solely for use with Cypress hardware products, only internally within your organization, and (b) to distribute the Software in binary code form externally to end users (either directly or indirectly through resellers and distributors), solely for use on Cypress hardware product units, and (2) under those claims of Cypress's patents that are infringed by the Software (as provided by Cypress, unmodified) to make, use, distribute, and import the Software solely for use with Cypress hardware products. Any other use, reproduction, modification, translation, or compilation of the Software is prohibited.

TO THE EXTENT PERMITTED BY APPLICABLE LAW, CYPRESS MAKES NO WARRANTY OF ANY KIND, EXPRESS OR IMPLIED, WITH REGARD TO THIS DOCUMENT OR ANY SOFTWARE OR ACCOMPANYING HARDWARE, INCLUDING, BUT NOT LIMITED TO, THE IMPLIED WARRANTIES OF MERCHANTABILITY AND FITNESS FOR A PARTICULAR PURPOSE. No computing device can be absolutely secure. Therefore, despite security measures implemented in Cypress hardware or software products, Cypress does not assume any liability arising out of any security breach, such as unauthorized access to or use of a Cypress product. In addition, the products described in these materials may contain design defects or errors known as errata which may cause the product to deviate from published specifications. To the extent permitted by applicable law, Cypress reserves the right to make changes to this document without further notice. Cypress does not assume any liability arising out of the application or use of any product or circuit described in this document. Any information provided in this document, including any sample design information or programming code, is provided only for reference purposes. It is the responsibility of the user of this document to properly design, program, and test the functionality and safety of any application made of this information and any resulting product. Cypress products are not designed, intended, or authorized for use as critical components in systems designed or intended for the operation of weapons, weapons systems, nuclear installations, life-support devices or systems, other medical devices or systems (including resuscitation equipment and surgical implants), pollution control or hazardous substances management, or other uses where the failure of the device or system could cause personal injury, death, or property damage ("Unintended Uses"). A critical component is any component of a device or system whose failure to perform can be reasonably expected to cause the failure of the device or system, or to affect its safety or effectiveness. Cypress is not liable, in whole or in part, and you shall and hereby do release Cypress from any claim, damage, or other liability arising from or related to all Unintended Uses of Cypress products. You shall indemnify and hold Cypress harmless from and against all claims, costs, damages, and other liabilities, including claims for personal injury or death, arising from or related to any Unintended Uses of Cypress products.

Cypress, the Cypress logo, Spansion, the Spansion logo, and combinations thereof, WICED, PSoC, CapSense, EZ-USB, F-RAM, and Traveo are trademarks or registered trademarks of Cypress in the United States and other countries. For a more complete list of Cypress trademarks, visit cypress.com. Other names and brands may be claimed as property of their respective owners.