

LTC4368

100V UV/OV and Reverse Protection Controller with Bidirectional Circuit Breaker

DESCRIPTION

Demonstration circuit 2418A is intended to demonstrate the performance of the [LTC®4368](#) 100V undervoltage (UV), overvoltage (OV), and reverse protection controller with bidirectional circuit breaker.

The LTC4368 protects circuits from overcurrent in both directions and from input voltages that may be too high, too low, or negative. The LTC4368 controls the gate voltage of two back-to-back connected external MOSFETs to ensure that the load is connected to the input supply only when there are no voltage or current faults. The OV and UV protection levels are adjusted by resistive dividers at the OV and UV pins, respectively. Asserting a low signal at the $\overline{\text{SHDN}}$ pin disables the MOSFETs and places the controller in a low-current shutdown state. The $\overline{\text{FAULT}}$ pin is asserted when the controller is in shutdown mode or when the input voltage is outside of the UV or OV window,

or the load current exceeds the protection level, or the input voltage is below undervoltage lockout (1.8V to 2.4V).

After a forward overcurrent fault, the LTC4368 will either latch off power or retry after a user adjustable delay. A reverse overcurrent fault waits for the output to fall 100mV below the input to reconnect power to the load.

The LTC4368 can withstand DC voltages between -40V and 100V and has an operating range of 2.5V to 60V .

The DC2418A includes the LTC4368 controller, two back-to-back connected power MOSFETs, current sense resistor, three jumpers, and three LEDs to indicate the input and output voltages and the $\overline{\text{FAULT}}$ pin signal.

Design files for this circuit board are available at <http://www.analog.com/DC2418A>

All registered trademarks and trademarks are the property of their respective owners.

PERFORMANCE SUMMARY

Specifications are at the full operating temperature range

SYMBOL	PARAMETER	CONDITIONS	MIN	TYP	MAX	UNITS
V_{IN}	Input Voltage Range for LTC4368	Operating Range	2.5		60	V
		Protection Range	-40		100	V
$V_{\text{IN(UVLO)}}$	Input Supply Undervoltage Lockout	V_{IN} Rising	1.8	2.2	2.4	V
I_{VIN}	Input Supply Current: Off On	$\overline{\text{SHDN}} = 0\text{V}$, $\text{SENSE} = V_{\text{OUT}}$ $\overline{\text{SHDN}} = 2.5\text{V}$, $\text{SENSE} = V_{\text{OUT}} = V_{\text{IN}}$		5	25	μA
				30	100	μA
$I_{\text{VIN(R)}}$	Reverse Input Supply Current	$V_{\text{IN}} = -40\text{V}$, $\text{SENSE} = V_{\text{OUT}} = 0\text{V}$		-1.5	-2.5	mA
$\Delta V_{\text{SENSE,F}}$	Overcurrent Fault Threshold, Forward ($\text{SENSE} - V_{\text{OUT}}$)	$V_{\text{OUT}} = V_{\text{IN}}$	40	50	60	mV
		$V_{\text{IN}} = 12\text{V}$, $V_{\text{OUT}} = 0.5\text{V}$	40	50	60	mV
		$V_{\text{IN}} = 12\text{V}$, $V_{\text{OUT}} = 0\text{V}$	30	50	70	mV
$\Delta V_{\text{SENSE,R}}$	Overcurrent Fault Threshold, Reverse ($\text{SENSE} - V_{\text{OUT}}$)	LTC4368-1 $V_{\text{OUT}} = V_{\text{IN}}$	-42	-50	-58	mV
		LTC4368-2 $V_{\text{OUT}} = V_{\text{IN}}$	-1	-3	-5	mV
ΔV_{RR}	Reverse Overcurrent Re-Enable Turn-On Threshold ($V_{\text{IN}} - V_{\text{OUT}}$)	$V_{\text{IN}} = \text{SENSE} = 6\text{V}$ to 60V	75	100	125	mV
		$V_{\text{IN}} = \text{SENSE} = 2.5\text{V}$ to <6	20	50	125	mV
ΔV_{GATE}	Gate Drive ($V_{\text{GATE}} - V_{\text{OUT}}$)	$V_{\text{IN}} = 2.5\text{V}$, $I_{\text{GATE}} = 0\mu\text{A}$, $-1\mu\text{A}$	3	4	5.5	V
		$V_{\text{IN}} = 5.0\text{V}$, $I_{\text{GATE}} = 0\mu\text{A}$, $-1\mu\text{A}$	7.2	8.7	10.8	V
		$V_{\text{IN}} = 12\text{V}$ to 60V , $I_{\text{GATE}} = -1\mu\text{A}$	10	11	13.1	V
$I_{\text{GATE(UP)}}$	Gate Pull-Up Current	$\text{GATE} = 15\text{V}$, $V_{\text{IN}} = 12\text{V}$	-20	-35	-60	μA
$I_{\text{GATE(SLOW)}}$	Gate Slow Pull-Down Current	$\text{GATE} = 20\text{V}$, $V_{\text{IN}} = 12\text{V}$	50	90	160	μA
$I_{\text{GATE(FAST)}}$	Gate Fast Pull-Down Current	$\text{GATE} = 20\text{V}$, $\text{SENSE} = V_{\text{IN}} = 12\text{V}$	30	60	90	mA

DEMO MANUAL DC2418A

PERFORMANCE SUMMARY Specifications are at $T_A = 25^\circ\text{C}$

SYMBOL	PARAMETER	CONDITIONS	MIN	TYP	MAX	UNITS
V_{UV}	UV Input Threshold Voltage	UV Falling	492.5	500	507.5	mV
V_{OV}	OV Input Threshold Voltage	OV Rising	429.5	500	507.5	mV
$t_{D(\text{FAST})}$	Gate Fast Turn-Off Delay	$C_{\text{GATE}} = 2.2\text{nF}$, UV, OV FAULT		2	6	μs
t_{FAULT}	OV, UV Fault Propagation Delay	Overdrive = 50mV, $V_{\text{IN}} = 12\text{V}$		1	2	μs
V_{SHDN}	SHDN Input Threshold	SHDN Falling	0.4	0.75	1.2	V
$V_{\text{UV_BOARD}}$	Board Overvoltage Threshold	DC2418A-A and DC2418A-B	17.37	17.98	18.61	V
$V_{\text{OV_BOARD}}$	Board Undervoltage Threshold	DC2418A-A and DC2418A-B	3.4	3.51	3.63	V
$I_{\text{LIM_FORW}}$	Board Forward Current Trip Threshold	DC2418A-A DC2418A-B	8.32 2.08	10 2.5	11.72 2.92	A A
$I_{\text{LIM_REVERS}}$	Board Reverse Current Trip Threshold	DC2418A-A DC2418A-B	8.32 0.05	10 0.15	12.12 0.253	A A

OPERATING PRINCIPLES

The LTC4368 monitors the input voltage and current sense resistor voltage. The controller disconnects a load from the power rail when the input voltage is too low, too high or negative, or when the voltage across the sense resistor exceeds 50mV or is less than -3mV for the LTC4368-2 or is less than -50mV for the LTC4368-1. The LTC4368 provides accurate overvoltage and undervoltage comparators to ensure that power is applied to the system only if the input supply is within the allowable voltage window. Reverse supply protection circuits automatically isolate the load from negative input voltages.

During normal operation, a high voltage charge pump enhances the gates of back-to-back external N-channel power MOSFETs.

The LTC4368 consumes 5 μA during shutdown state and 80 μA while operating.

The demo board includes the LTC4368 protection controller, two back-to-back connected N-channel MOSFETs, the resistive divider for UV and OV threshold adjustment, sense resistor for overcurrent protection, a few LEDs, and jumpers for visual information and to control signal assignment. There is an option for retry operation with two selectable cool-down time periods or for latch-off after a forward overcurrent fault.

The DC2418A is available in two versions, DC2418A-A and DC2418A-B, as shown on the board schematic.

The DC2418A-A is populated with:

- LTC4368-1 having a reverse overcurrent circuit breaker threshold of -50mV
- SiR870ADP MOSFETs and 5m Ω sense resistor for 10A maximum load

And the DC2418A-B has:

- LTC4368-2 having a reverse overcurrent circuit breaker threshold of -3mV
- SiR7942DP dual MOSFET and 20m Ω sense resistor for 2.5A maximum load

Turrets

V_{IN} (E1, E10): Power rail input.

GND (E2, E9, E7, E12): Power and control ground.

V_{OUT} (E6, E13): Circuit output for load connection.

UV (E3): UV pin.

OV (E4): OV pin.

$\overline{\text{SHDN}}$ (E5): $\overline{\text{SHDN}}$ pin.

$\overline{\text{FAULT}}$ (E8): $\overline{\text{FAULT}}$ pin.

Jumpers

- JP1: ($\overline{\text{SHDN}}$) Enable (EN) or Disable (DIS) Controller.
 JP2: (V_{IN}) Power or unpower LEDs, green D1 and red D3.
 JP3: (V_{OUT}) Power or unpower green LED D2.
 JP4: (COOL-DOWN-TIME) Select cool-down time 1320ms, 120ms, or place controller in latch-off operation.

LEDs

- D1: Indicates input voltage is present.
 D2: Indicates output voltage is present.
 D3: Indicates $\overline{\text{FAULT}}$ pin signal (a fault turns on this LED).

QUICK START PROCEDURE

DC2418A is easy to set up to evaluate the performance of LTC4368. Refer to Figure 1 and Figure 2 for proper measurement equipment setup and follow the procedure below.

Reverse Voltage Protection Test

1. Set JP1 to EN.
2. Set JP2 and JP3 to CONNECT LED.
3. Connect a power supply across V_{IN} and GND in negative configuration (connect its positive terminal to GND and negative to V_{IN}).
4. Connect a power supply across V_{OUT} and GND and set to 0V.
5. Connect the ammeters in series with V_{IN} and V_{OUT} .
6. Slowly ramp supply down to -40V (referenced to GND). Make sure this voltage does not exceed -40V.
7. Verify all LEDs are off, input current is $<3\mu\text{A}$ and output current is $<100\mu\text{A}$.
8. Ramp supply back to 0V.

Undervoltage/Overvoltage Protection Test

1. Reverse the polarity of power supply connection across V_{IN} to GND (connect supply's positive terminal to V_{IN} and negative to GND).
2. Slowly ramp supply up to 100V and verify that green V_{IN} LED and red $\overline{\text{FAULT}}$ LED light up, but green V_{OUT} LED does not light up.
3. Ramp supply down from 60V to 0V and verify green V_{IN} LED, red $\overline{\text{FAULT}}$ LED, green V_{OUT} LED, and V_{OUT} operate according to the following table.

V_{IN}	V_{OUT}	V_{IN} LED	V_{OUT} LED	$\overline{\text{FAULT}}$ LED
0V to 3.5V	0V	Off/Dim/On	Off	On
3.5V to 18V	V_{IN}	On	On	Off
18V to 60V	0V	On	Off	On

Forward Overcurrent Protection Test

1. Place JP1 in position DIS and JP2 and JP3 in position CONNECT LED.
2. Connect +5V supply to V_{IN} .
3. Enable LTC4368 by changing the position JP1 to EN. Confirm that output voltage is +5V.
4. Load the DC2418A-A board output with 0.4Ω (25W) resistor or DC2518A-B board with 1.5Ω . Confirm that the output load is disconnected from power. The load should be placed between the V_{OUT} and GND turrets.
5. Repeat steps 3 and 4 with a 7.8A load for DC2418A-A and a 1.9A load for DC2418A-B. Confirm that the output is not disconnected (V_{OUT} should be close to V_{IN} and not at ground).

Jumper Test

1. Remove the load and set the V_{IN} supply to 9V.
2. Move jumpers and verify LEDs light up according to table below.

JP1	JP2/JP3	V_{IN} LED	V_{OUT} LED
EN	CONNECT LED	On	On
DIS	CONNECT LED	On	Off
EN	OPEN	Off	Off

QUICK START PROCEDURE

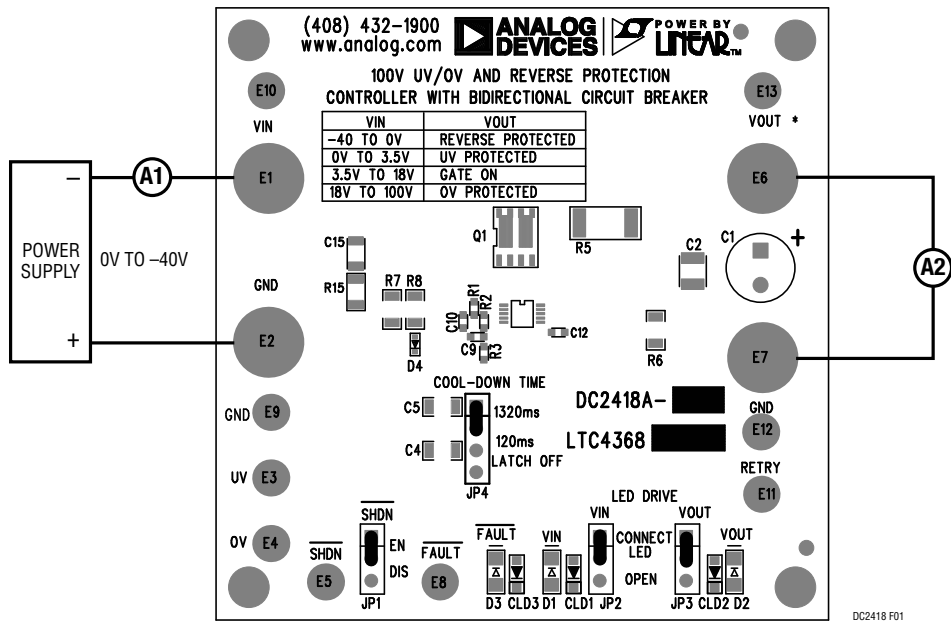

Figure 1. Reverse Voltage Protection Test

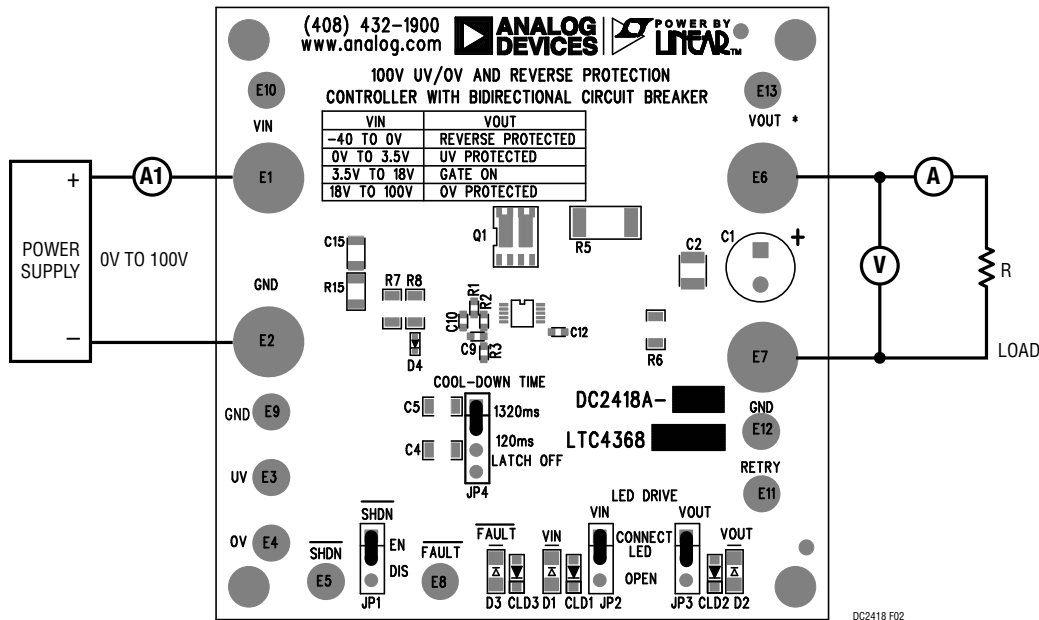
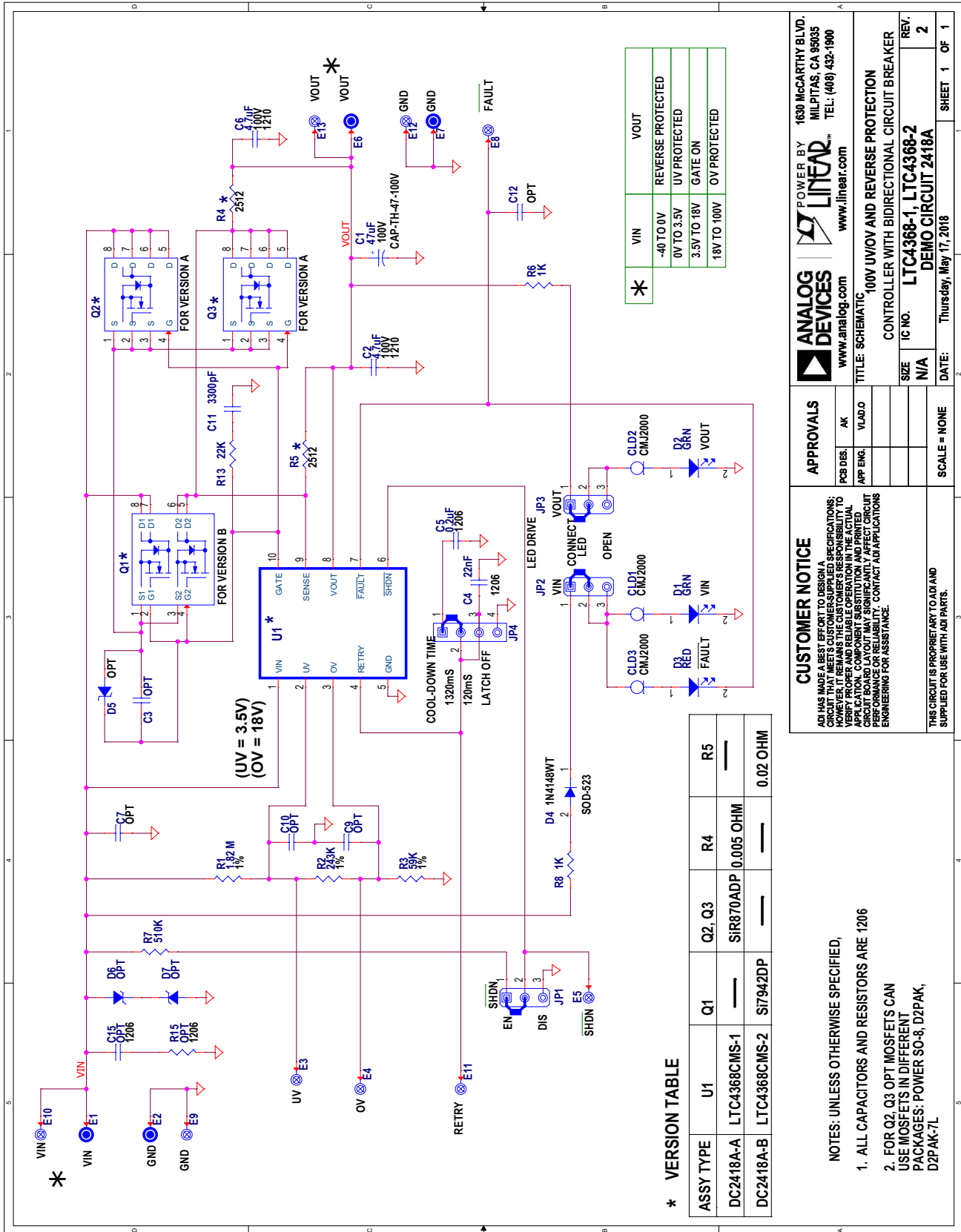

Figure 2. Undervoltage/Overvoltage Test and Forward Overcurrent Protection Test

SCHEMATIC DIAGRAM



Information furnished by Analog Devices is believed to be accurate and reliable. However, no responsibility is assumed by Analog Devices for its use, nor for any infringements of patents or other rights of third parties that may result from its use. Specifications subject to change without notice. No license is granted by implication or otherwise under any patent or patent rights of Analog Devices.



ESD Caution

ESD (electrostatic discharge) sensitive device. Charged devices and circuit boards can discharge without detection. Although this product features patented or proprietary protection circuitry, damage may occur on devices subjected to high energy ESD. Therefore, proper ESD precautions should be taken to avoid performance degradation or loss of functionality.

Legal Terms and Conditions

By using the evaluation board discussed herein (together with any tools, components documentation or support materials, the "Evaluation Board"), you are agreeing to be bound by the terms and conditions set forth below ("Agreement") unless you have purchased the Evaluation Board, in which case the Analog Devices Standard Terms and Conditions of Sale shall govern. Do not use the Evaluation Board until you have read and agreed to the Agreement. Your use of the Evaluation Board shall signify your acceptance of the Agreement. This Agreement is made by and between you ("Customer") and Analog Devices, Inc. ("ADI"), with its principal place of business at One Technology Way, Norwood, MA 02062, USA. Subject to the terms and conditions of the Agreement, ADI hereby grants to Customer a free, limited, personal, temporary, non-exclusive, non-sublicensable, non-transferable license to use the Evaluation Board FOR EVALUATION PURPOSES ONLY. Customer understands and agrees that the Evaluation Board is provided for the sole and exclusive purpose referenced above, and agrees not to use the Evaluation Board for any other purpose. Furthermore, the license granted is expressly made subject to the following additional limitations: Customer shall not (i) rent, lease, display, sell, transfer, assign, sublicense, or distribute the Evaluation Board; and (ii) permit any Third Party to access the Evaluation Board. As used herein, the term "Third Party" includes any entity other than ADI, Customer, their employees, affiliates and in-house consultants. The Evaluation Board is NOT sold to Customer; all rights not expressly granted herein, including ownership of the Evaluation Board, are reserved by ADI. CONFIDENTIALITY. This Agreement and the Evaluation Board shall all be considered the confidential and proprietary information of ADI. Customer may not disclose or transfer any portion of the Evaluation Board to any other party for any reason. Upon discontinuation of use of the Evaluation Board or termination of this Agreement, Customer agrees to promptly return the Evaluation Board to ADI. ADDITIONAL RESTRICTIONS. Customer may not disassemble, decompile or reverse engineer chips on the Evaluation Board. Customer shall inform ADI of any occurred damages or any modifications or alterations it makes to the Evaluation Board, including but not limited to soldering or any other activity that affects the material content of the Evaluation Board. Modifications to the Evaluation Board must comply with applicable law, including but not limited to the RoHS Directive. TERMINATION. ADI may terminate this Agreement at any time upon giving written notice to Customer. Customer agrees to return to ADI the Evaluation Board at that time. LIMITATION OF LIABILITY. THE EVALUATION BOARD PROVIDED HEREUNDER IS PROVIDED "AS IS" AND ADI MAKES NO WARRANTIES OR REPRESENTATIONS OF ANY KIND WITH RESPECT TO IT. ADI SPECIFICALLY DISCLAIMS ANY REPRESENTATIONS, ENDORSEMENTS, GUARANTEES, OR WARRANTIES, EXPRESS OR IMPLIED, RELATED TO THE EVALUATION BOARD INCLUDING, BUT NOT LIMITED TO, THE IMPLIED WARRANTY OF MERCHANTABILITY, TITLE, FITNESS FOR A PARTICULAR PURPOSE OR NON-INFRINGEMENT OF INTELLECTUAL PROPERTY RIGHTS. IN NO EVENT WILL ADI AND ITS LICENSORS BE LIABLE FOR ANY INCIDENTAL, SPECIAL, INDIRECT, OR CONSEQUENTIAL DAMAGES RESULTING FROM CUSTOMER'S POSSESSION OR USE OF THE EVALUATION BOARD, INCLUDING BUT NOT LIMITED TO LOST PROFITS, DELAY COSTS, LABOR COSTS OR LOSS OF GOODWILL. ADI'S TOTAL LIABILITY FROM ANY AND ALL CAUSES SHALL BE LIMITED TO THE AMOUNT OF ONE HUNDRED US DOLLARS (\$100.00). EXPORT. Customer agrees that it will not directly or indirectly export the Evaluation Board to another country, and that it will comply with all applicable United States federal laws and regulations relating to exports. GOVERNING LAW. This Agreement shall be governed by and construed in accordance with the substantive laws of the Commonwealth of Massachusetts (excluding conflict of law rules). Any legal action regarding this Agreement will be heard in the state or federal courts having jurisdiction in Suffolk County, Massachusetts, and Customer hereby submits to the personal jurisdiction and venue of such courts. The United Nations Convention on Contracts for the International Sale of Goods shall not apply to this Agreement and is expressly disclaimed.