

# BGM210P Blue Gecko Bluetooth Module

## Data Sheet



The BGM210P is a module designed and built to meet the performance, security, and reliability requirements of line-powered IoT products for Bluetooth networks.

Based on the EFR32BG21 SoC, it enables Bluetooth® Low Energy and Bluetooth Mesh connectivity while delivering best-in-class RF range and performance, future-proof capability for feature and OTA firmware updates, enhanced security, low active current consumption, and a temperature rating suited for operating in demanding environmental conditions.

The BGM210P is a complete solution that comes with robust and fully-upgradeable software stacks, world-wide regulatory certifications, advanced development and debugging tools, and support that will simplify and minimize the development cycle and deployment of your end-product helping to accelerate its time-to-market.

The BGM210P is targeted for a broad range of applications, including:

- Smart home
- Connected lighting
- Building automation and security
- Factory automation

### KEY FEATURES

- Bluetooth 5.1 and Bluetooth Mesh connectivity
- Chip antenna and RF pin
- +10 and +20 dBm TX power variants
- -97.0 dBm Bluetooth RX sensitivity at 1 Mbps
- 32-bit ARM Cortex-M33 core at 38.4 MHz
- 1024/96 kB of Flash/RAM memory
- Enhanced security features
- Optimal set of MCU peripherals
- 20 GPIO pins
- -40 to +125 °C
- 12.9 mm x 15.0 mm x 2.2 mm

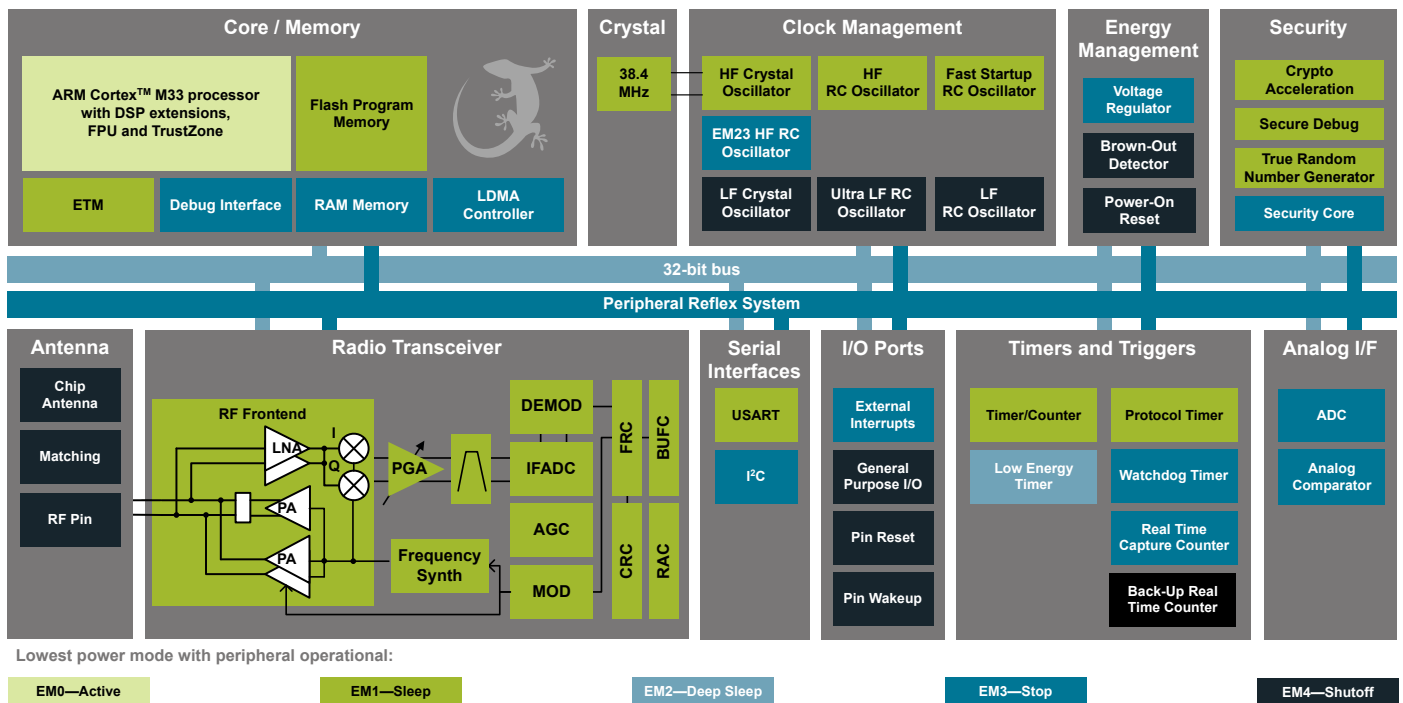

## 1. Features

- **Supported Protocols**
  - Bluetooth 5.1
    - Bluetooth Low Energy
    - Bluetooth Mesh
    - AoA/AoD
- **Wireless System-on-Chip**
  - 2.4 GHz radio
  - TX power up to +20 dBm
  - High-performance 32-bit ARM Cortex-M33<sup>®</sup> with DSP instruction and floating-point unit for efficient signal processing
  - 1024 kB flash program memory
  - 96 kB RAM data memory
  - Embedded Trace Macrocell (ETM) for advanced debugging
- **Receiver Performance**
  - -104.5 dBm sensitivity (0.1% BER) at 125 kbps GFSK
  - -100.1 dBm sensitivity (0.1% BER) at 500 kbps GFSK
  - -97.0 dBm sensitivity (0.1% BER) at 1 Mbps GFSK
  - -94.1 dBm sensitivity (0.1% BER) at 2 Mbps GFSK
- **Current Consumption**
  - 9.3 mA RX current at 1 Mbps GFSK
  - 16.1 mA TX current at 0 dBm (BGM210Px22)
  - 34.1 mA TX current at 10 dBm (BGM210Px22)
  - 173 mA TX current at 20 dBm (BGM210Px32)
  - 50.9µA/MHz in Active Mode (EM0)
  - 5.1µA EM2 DeepSleep current (RTCC running from LFXO, Bluetooth Stack not running)
  - 8.5µA EM2 DeepSleep current (RTCC running from LFXO, Bluetooth Stack running)
- **Regulatory Certifications**
  - CE
  - ISED
  - FCC
- **Operating Range**
  - 1.8 to 3.8 V
  - -40 to +125 °C
- **Dimensions**
  - 12.9 mm x 15.0 mm x 2.2 mm
- **Security**
  - Secure Boot with Root of Trust and Secure Loader (RTSL)<sup>1</sup>
  - Hardware Cryptographic Acceleration with DPA countermeasures<sup>1</sup> for AES128/256, SHA-1, SHA-2 (up to 256-bit), ECC (up to 256-bit), ECDSA, and ECDH
  - True Random Number Generator (TRNG) compliant with NIST SP800-90 and AIS-31
  - ARM<sup>®</sup> TrustZone<sup>®</sup>
  - Secure Debug Interface lock/unlock
- **MCU Peripherals**
  - 12-bit 1 Msps SAR Analog to Digital Converter (ADC)
  - 2 × Analog Comparator (ACMP)
  - 20 General Purpose I/O pins with output state retention and asynchronous interrupts
  - 8 Channel DMA Controller
  - 12 Channel Peripheral Reflex System (PRS)
  - 2 × 16-bit Timer/Counter (3 Compare/Capture/PWM channels)
  - 1 × 32-bit Timer/Counter (3 Compare/Capture/PWM channels)
  - 32-bit Real Time Counter
  - 24-bit Low Energy Timer for waveform generation
  - 2 × Watchdog Timer
  - 3 × Universal Synchronous/Asynchronous Receiver/Transmitter (UART/SPI/SmartCard (ISO 7816)/IrDA/I<sup>2</sup>S)
  - 2 × I<sup>2</sup>C interface with SMBus support

1. With Secure Element (SE) firmware v1.1.2 or newer

## 2. Ordering Information

**Table 2.1. Ordering Information**

Ordering Code	Protocol Stack	TX Power	Freq Band	Antenna	Flash (kB)	RAM (kB)	GPIO	Temp Range	Packaging
BGM210P022JIA2 <sup>1</sup>	• Bluetooth 5.1	10 dBm	2.4 GHz	Chip and RF pin	1024	96	20	-40 to 125 °C	Cut Tape
BGM210P022JIA2R <sup>1</sup>	• Bluetooth 5.1	10 dBm	2.4 GHz	Chip and RF pin	1024	96	20	-40 to 125 °C	Reel
BGM210P032JIA2 <sup>1</sup>	• Bluetooth 5.1	20 dBm	2.4 GHz	Chip and RF pin	1024	96	20	-40 to 125 °C	Cut Tape
BGM210P032JIA2R <sup>1</sup>	• Bluetooth 5.1	20 dBm	2.4 GHz	Chip and RF pin	1024	96	20	-40 to 125 °C	Reel
BGM210PA22JIA2 <sup>2</sup>	• Bluetooth 5.1	10 dBm	2.4 GHz	Chip and RF pin	1024	96	20	-40 to 125 °C	Cut Tape
BGM210PA22JIA2R <sup>2</sup>	• Bluetooth 5.1	10 dBm	2.4 GHz	Chip and RF pin	1024	96	20	-40 to 125 °C	Reel
BGM210PA32JIA2 <sup>2</sup>	• Bluetooth 5.1	20 dBm	2.4 GHz	Chip and RF pin	1024	96	20	-40 to 125 °C	Cut Tape
BGM210PA32JIA2R <sup>2</sup>	• Bluetooth 5.1	20 dBm	2.4 GHz	Chip and RF pin	1024	96	20	-40 to 125 °C	Reel

1. Engineering sample device

2. Production device

See [4.5 RF Transmitter General Characteristics](#) for maximum TX power figures.

End-product manufacturers must verify that the module is configured to comply with the regulatory limits for each region, in accordance with the formal certification test reports for the device.

BGM210P modules are pre-programmed with BGAPI UART DFU bootloader.

Throughout this document, the devices above may be referred to by their product family name (BGM210P), model name (BGM210P22A / BGM210P32A) or full ordering code.

The **SLWSTK6102A Wireless Gecko Module Starter Kit** is available for BGM210P evaluation and development, as well as **SLWRB4308A** (+20 dBm TX) and **SLWRB4308B** (+10 dBm TX) radio boards.

# Table of Contents

<b>1. Features</b>	<b>2</b>
<b>2. Ordering Information</b>	<b>3</b>
<b>3. System Overview</b>	<b>6</b>
3.1 Block Diagram	6
3.2 EFR32BG21 SoC	6
3.3 Antenna	6
3.4 Power Supply	6
<b>4. Electrical Specifications</b>	<b>7</b>
4.1 Absolute Maximum Ratings	7
4.2 General Operating Conditions	8
4.3 MCU Current Consumption at 3.0V	9
4.4 Radio Current Consumption at 3.0V	10
4.5 RF Transmitter General Characteristics	11
4.6 RF Receiver General Characteristics	12
4.7 RF Receiver Characteristics for Bluetooth Low Energy at 1 Mbps	13
4.8 RF Receiver Characteristics for Bluetooth Low Energy at 2 Mbps	14
4.9 RF Receiver Characteristics for Bluetooth Low Energy at 500 kbps	15
4.10 RF Receiver Characteristics for Bluetooth Low Energy at 125 kbps	16
4.11 High-Frequency Crystal	17
4.12 GPIO Pins	18
4.13 Microcontroller Peripherals	19
4.14 Typical Performance Curves	19
4.14.1 Antenna Radiation and Efficiency	20
<b>5. Reference Diagrams</b>	<b>21</b>
5.1 Network Co-Processor (NCP) Application with UART Host	21
5.2 SoC Application	22
<b>6. Pin Definitions</b>	<b>23</b>
6.1 Module Pinout	23
6.2 Alternate Pin Functions	24
6.3 Analog Peripheral Connectivity	24
6.4 Digital Peripheral Connectivity	25
<b>7. Design Guidelines</b>	<b>28</b>
7.1 Layout and Placement	28
7.2 Proximity to Other Materials	29
7.3 Proximity to Human Body	29

- 8. Package Specifications . . . . . 30**
  - 8.1 Dimensions . . . . . 30
  - 8.2 PCB Land Pattern . . . . . 31
  - 8.3 Package Marking . . . . . 32
- 9. Soldering Recommendations . . . . . 33**
- 10. Tape and Reel . . . . . 34**
- 11. Certifications . . . . . 35**
  - 11.1 Qualified Antennas . . . . . 35
  - 11.2 CE . . . . . 35
  - 11.3 FCC . . . . . 35
  - 11.4 ISED Canada . . . . . 38
  - 11.5 Proximity to Human Body . . . . . 40
- 12. Revision History. . . . . 41**

### 3. System Overview

#### 3.1 Block Diagram

The BGM210P module is a highly-integrated, high-performance system with all the hardware components needed to enable 2.4 GHz wireless connectivity and to support robust networking capabilities via multiple protocols.

Built around the EFR32BG21 Wireless Gecko SoC, the BGM210P includes a chip antenna, an RF matching network (optimized for transmit power efficiency), supply decoupling and filtering components, a 38.4 MHz reference crystal, and an RF shield. It also comes with a 50 Ω-matched RF pin and allows the use of an external 32 kHz crystal as a low frequency reference signal via GPIO pins.

Since the RF matching networks are optimized for transmit power efficiency, modules rated for +20 dBm will show non-optimal current consumption and performance when operated at a lower output power (e.g. +10 or 0 dBm). The same applies for modules rated for +10 dBm.

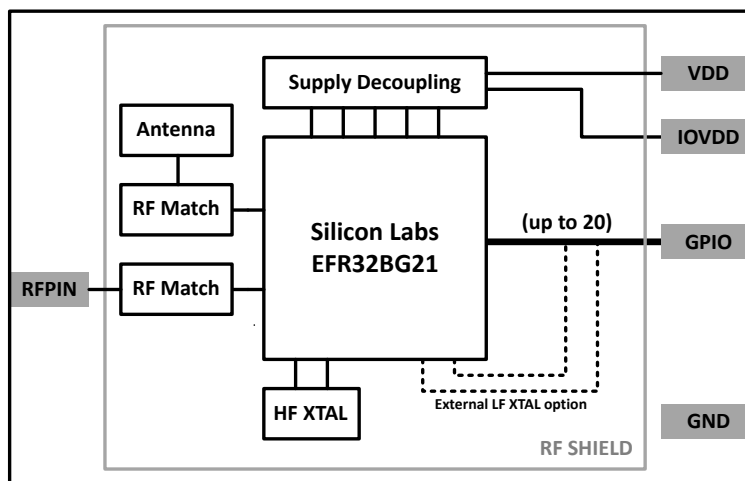

Figure 3.1. BGM210P Block Diagram

#### 3.2 EFR32BG21 SoC

The EFR32BG21 SoC features a 32-bit ARM Cortex M33 core, a 2.4 GHz high-performance radio, 1 MB of Flash memory, a dedicated core for security, a rich set of MCU peripherals, and various clock management and serial interfacing options. Consult the [EFR32xG21 Wireless Gecko Reference Manual](#) and the [EFR32BG21 Data Sheet](#) for details.

#### 3.3 Antenna

BGM210P modules include a ceramic chip antenna on board with the characteristics detailed in the table below. They also include a 50 Ω-matched RF pin to enable the use of an external antenna instead of the module's chip antenna. See [4.14.1 Antenna Radiation and Efficiency](#) and [11.1 Qualified Antennas](#) for other relevant details.

Table 3.1. Antenna Efficiency and Peak Gain

Parameter	With optimal layout	Note
Efficiency	-1 to -2 dB	Antenna efficiency, gain and radiation pattern are highly dependent on the application PCB layout and mechanical design. Refer to <a href="#">Design Guidelines</a> for recommendations to achieve optimal antenna performance.
Peak gain	1.86 dBi	

#### 3.4 Power Supply

The BGM210P requires a single nominal supply level of 3.0 V to operate. However, it can support use cases needing different levels for the main supply (VDD) and for digital IO (IOVDD). All necessary decoupling and filtering components are included in the module.

## 4. Electrical Specifications

All electrical parameters in all tables are specified under the following conditions, unless stated otherwise:

- Typical values are based on  $T_A=25\text{ }^\circ\text{C}$  and VDD supply at 3.0 V, by production test and/or technology characterization.
- Radio performance numbers are measured in conducted mode, based on Silicon Laboratories reference designs using output power-specific external RF impedance-matching networks for interfacing to a 50  $\Omega$  antenna.
- Minimum and maximum values represent the worst conditions across supply voltage, process variation, and operating temperature, unless stated otherwise.

### 4.1 Absolute Maximum Ratings

Stresses above those listed below may cause permanent damage to the device. This is a stress rating only and functional operation of the devices at those or any other conditions above those indicated in the operation listings of this specification is not implied. Exposure to maximum rating conditions for extended periods may affect device reliability. For more information on the available quality and reliability data, see the Quality and Reliability Monitor Report at <http://www.silabs.com/support/quality/pages/default.aspx>.

**Table 4.1. Absolute Maximum Ratings**

Parameter	Symbol	Test Condition	Min	Typ	Max	Unit
Storage temperature range	$T_{STG}$		-50	—	+150	$^\circ\text{C}$
Voltage on any supply pin	$V_{DDMAX}$		-0.3	—	3.8	V
Voltage ramp rate on VDD supply pin	$V_{DDRAMPMAX}$		—	—	1.0	V / $\mu\text{s}$
DC voltage on any GPIO pin	$V_{DIGPIN}$		-0.3	—	$V_{IOVDD} + 0.3$	V
Total current into VDD power lines	$I_{VDDMAX}$	Source	—	—	200	mA
Total current into GND pin	$I_{GNDDMAX}$	Sink	—	—	200	mA
Current per I/O pin	$I_{IOMAX}$	Sink	—	—	50	mA
		Source	—	—	50	mA
Current for all I/O pins	$I_{IOALLMAX}$	Sink	—	—	200	mA
		Source	—	—	200	mA

## 4.2 General Operating Conditions

This table specifies the general operating temperature range and supply voltage range for all supplies. The minimum and maximum values of all other tables are specified over this operating range, unless otherwise noted.

**Table 4.2. General Operating Conditions**

Parameter	Symbol	Test Condition	Min	Typ	Max	Unit
Operating ambient temperature range	$T_A$	-I temperature grade	-40	—	+125	° C
VDD Supply Voltage	$V_{DD}$		1.8	3.0	3.8	V
IOVDD operating supply voltage (All IOVDD pins)	$V_{IOVDD}$		1.8	3.0	3.8	V
HCLK and Core frequency	$f_{HCLK}$	MODE = WS1, RAMWSEN = 1 <sup>1</sup>	—	—	80	MHz
		MODE = WS1, RAMWSEN = 0 <sup>1</sup>	—	—	50	MHz
		MODE = WS0, RAMWSEN = 0 <sup>1</sup>	—	—	39	MHz
PCLK frequency	$f_{PCLK}$		—	—	50	MHz
EM01 Group A clock frequency	$f_{EM01GRPACLK}$		—	—	80	MHz
HCLK Radio frequency	$f_{HCLKRADIO}$		38	38.4	40	MHz
<b>Note:</b> 1. Flash wait states are set by the MODE field in the MSC_READCTRL register. RAM wait states are enabled by setting the RAMWSEN bit in the SYSYCFG_DMEM0RAMCTRL register.						



### 4.3 MCU Current Consumption at 3.0V

Unless otherwise indicated, typical conditions are: VDD = 3.0 V. T<sub>A</sub> = 25 °C. Minimum and maximum values in this table represent the worst conditions across process variation at T<sub>A</sub> = 25 °C.

**Table 4.3. MCU Current Consumption at 3.0V**

Parameter	Symbol	Test Condition	Min	Typ	Max	Unit
Current consumption in EM0 mode with all peripherals disabled <sup>1</sup>	I <sub>ACTIVE</sub>	80 MHz HFRCO, CPU running Prime from flash	—	50.9	—	µA/MHz
		80 MHz HFRCO, CPU running while loop from flash	—	45.6	55.5	µA/MHz
		80 MHz HFRCO, CPU running CoreMark loop from flash	—	59.8	—	µA/MHz
		38.4 MHz crystal, CPU running while loop from flash	—	63.8	—	µA/MHz
Current consumption in EM1 mode with all peripherals disabled <sup>1</sup>	I <sub>EM1</sub>	80 MHz HFRCO	—	28.7	37.6	µA/MHz
		38.4 MHz crystal	—	46.9	—	µA/MHz
Current consumption in EM2 mode	I <sub>EM2</sub>	Full RAM retention and RTC running from LFXO (Bluetooth Stack not running)	—	5.1	—	µA
		Full RAM retention, RTCC running, and Bluetooth Stack running from LFXO	—	8.5	—	µA
		1 bank (16 kB) RAM retention and RTC running from LFRCO	—	4.5	10.5	µA
Current consumption in EM3 mode	I <sub>EM3</sub>	Full RAM retention and RTC running from ULFRCO	—	4.8	11.4	µA
		1 bank (16 kB) RAM retention and RTC running from ULFRCO	—	4.3	—	µA
Current consumption in EM4 mode	I <sub>EM4</sub>	No BURTC, no LF oscillator	—	0.21	0.5	µA
Current consumption during reset	I <sub>RST</sub>	Hard pin reset held	—	146	—	µA
Current consumption per retained 16kB RAM bank in EM2	I <sub>RAM</sub>		—	0.10	—	µA

**Note:**

1. The typical EM0/EM1 current measurement includes some current consumed by the security core for periodical housekeeping purposes. This does not include current consumed by user-triggered security operations, such as cryptographic calculations.

#### 4.4 Radio Current Consumption at 3.0V

RF current consumption measured with MCU in EM1, HCLK = 38.4 MHz, and all MCU peripherals disabled. Unless otherwise indicated, typical conditions are: VDD = 3.0V. T<sub>A</sub> = 25 °C. Minimum and maximum values in this table represent the worst conditions across process variation at T<sub>A</sub> = 25 °C.

**Table 4.4. Radio Current Consumption at 3.0V**

Parameter	Symbol	Test Condition	Min	Typ	Max	Unit
Current consumption in receive mode, active packet reception	I <sub>RX_ACTIVE</sub>	125 kbit/s, 2GFSK, f = 2.4 GHz, Bluetooth stack running	—	9.3	—	mA
		500 kbit/s, 2GFSK, f = 2.4 GHz, Bluetooth stack running	—	9.3	—	mA
		1 Mbit/s, 2GFSK, f = 2.4 GHz, Bluetooth stack running	—	9.3	—	mA
		2 Mbit/s, 2GFSK, f = 2.4 GHz, Bluetooth stack running	—	9.9	—	mA
Current consumption in receive mode, Stack running	I <sub>RX_LISTEN</sub>	125 kbit/s, 2GFSK, f = 2.4 GHz, Bluetooth stack running	—	9.1	—	mA
		500 kbit/s, 2GFSK, f = 2.4 GHz, Bluetooth stack running	—	9.1	—	mA
		1 Mbit/s, 2GFSK, f = 2.4 GHz, Bluetooth stack running	—	9.1	—	mA
		2 Mbit/s, 2GFSK, f = 2.4 GHz, Bluetooth stack running	—	9.8	—	mA
Current consumption in transmit mode	I <sub>TX</sub>	f = 2.4 GHz, CW, 10 dBm Module, 0 dBm output power	—	16.1	—	mA
		f = 2.4 GHz, CW, 10 dBm Module, 10 dBm output power	—	34.1	—	mA
		f = 2.4 GHz, CW, 20 dBm Module, 10 dBm output power, VDD = 3.0 V	—	59.7	—	mA
		f = 2.4 GHz, CW, 20 dBm Module, P <sub>OUT</sub> = 19.2 dBm, VDD = 3.3 V <sup>1</sup>	—	173	—	mA

**Note:**

1. The maximum power for Bluetooth Low-Energy is limited to 19.2 dBm.

#### 4.5 RF Transmitter General Characteristics

Unless otherwise indicated, typical conditions are:  $T_A = 25\text{ }^\circ\text{C}$ ,  $V_{DD} = 3.0\text{V}$ . Measured with RF center frequency of 2.45 GHz on RF2G4\_IO2 port.

**Table 4.5. RF Transmitter General Characteristics**

Parameter	Symbol	Test Condition	Min	Typ	Max	Unit
RF tuning frequency range	$F_{\text{RANGE}}$		2400	—	2483.5	MHz
Maximum TX output power <sup>1</sup>	$P_{\text{OUT}_{\text{MAX}}}$	20 dBm Module, BLE, $V_{DD} = 3.3\text{V}^2$	—	19.2	—	dBm
		10 dBm Module	—	10	—	dBm
Minimum active TX Power	$P_{\text{OUT}_{\text{MIN}}}$	20 dBm Module, $V_{DD} = 3.3\text{V}$	—	-20.5	—	dBm
		10 dBm Module	—	-19.3	—	dBm
Output power step size	$P_{\text{OUT}_{\text{STEP}}}$	10 dBm Module, $-5\text{ dBm} < P_{\text{OUT}} < 0\text{ dBm}$	—	1.5	—	dB
		10 dBm Module, $0\text{ dBm} < P_{\text{OUT}} < 10\text{ dBm}$	—	1.0	—	dB
		20 dBm Module, $0\text{ dBm} < P_{\text{OUT}} < 5\text{ dBm}$	—	0.7	—	dB
		20 dBm Module, $5\text{ dBm} < P_{\text{OUT}} < P_{\text{OUT}_{\text{MAX}}}$	—	0.5	—	dB
Output power variation vs VDD supply voltage, Freq = 2450MHz	$P_{\text{OUT}_{\text{VAR}_V}}$	20 dBm Module, $P_{\text{OUT}} = P_{\text{OUT}_{\text{MAX}}}$ VDD swept from 3.0V to 3.8V.	—	1.0	—	dB
		10 dBm Module, $P_{\text{OUT}} = P_{\text{OUT}_{\text{MAX}}}$ VDD swept from 1.8V to 3.0V.	—	0.2	—	dB
Output power variation vs temperature, Freq = 2450MHz	$P_{\text{OUT}_{\text{VAR}_T}$	20 dBm Module, $P_{\text{OUT}} = P_{\text{OUT}_{\text{MAX}}}$ , $V_{DD} = 3.3\text{V}$ , temperature swept from $-40$ to $+125\text{ }^\circ\text{C}$ .	—	1.5	—	dB
		10 dBm Module, $P_{\text{OUT}} = P_{\text{OUT}_{\text{MAX}}}$ , $V_{DD} = 3.0\text{V}$ , temperature swept from $-40$ to $+125\text{ }^\circ\text{C}$ .	—	0.3	—	dB
Output power variation vs RF frequency	$P_{\text{OUT}_{\text{VAR}_F}$	20 dBm Module, $P_{\text{OUT}} = P_{\text{OUT}_{\text{MAX}}}$ , $V_{DD} = 3.3\text{V}$ , Freq. swept from 2400 to 2483.5 MHz	—	0.2	—	dB
		10 dBm Module, $P_{\text{OUT}} = P_{\text{OUT}_{\text{MAX}}}$ , $V_{DD} = 3.0\text{V}$ , Freq. swept from 2400 to 2483.5 MHz	—	0.2	—	dB

**Note:**

1. Supported transmit power levels are determined by the ordering part number (OPN). Transmit power ratings for all devices covered in this data sheet can be found in the TX Power column of the Ordering Information Table.
2. The maximum power for Bluetooth Low-Energy.

#### 4.6 RF Receiver General Characteristics

Unless otherwise indicated, typical conditions are:  $T_A = 25\text{ }^\circ\text{C}$ ,  $V_{DD} = 3.0\text{V}$ . Measured with RF center frequency of 2.45 GHz on RF2G4\_IO2 port.

**Table 4.6. RF Receiver General Characteristics**

Parameter	Symbol	Test Condition	Min	Typ	Max	Unit
RF tuning frequency range	$F_{\text{RANGE}}$		2400	—	2483.5	MHz

#### 4.7 RF Receiver Characteristics for Bluetooth Low Energy at 1 Mbps

Unless otherwise indicated, typical conditions are:  $T_A = 25\text{ }^\circ\text{C}$ ,  $V_{DD} = 3.0\text{V}$ . RF center frequency 2.45 GHz. Measured on RF2G4\_IO2.

**Table 4.7. RF Receiver Characteristics for Bluetooth Low Energy at 1 Mbps**

Parameter	Symbol	Test Condition	Min	Typ	Max	Unit
Max usable receiver input level	SAT	Signal is reference signal, packet length is 37 bytes <sup>1</sup>	—	10	—	dBm
Sensitivity	SENS	Signal is reference signal, 37 byte payload <sup>1</sup>	—	-97.0	—	dBm
		With non-ideal signals <sup>2 1</sup>	—	-96.7	—	dBm
Signal to co-channel interferer	$C/I_{CC}$	(see notes) <sup>1 3</sup>	—	+6.6	—	dB
$N \pm 1$ Adjacent channel selectivity	$C/I_1$	Interferer is reference signal at +1 MHz offset <sup>1 4 3 5</sup>	—	-8.3	—	dB
		Interferer is reference signal at -1 MHz offset <sup>1 4 3 5</sup>	—	-8.7	—	dB
$N \pm 2$ Alternate channel selectivity	$C/I_2$	Interferer is reference signal at +2 MHz offset <sup>1 4 3 5</sup>	—	-42.1	—	dB
		Interferer is reference signal at -2 MHz offset <sup>1 4 3 5</sup>	—	-48.9	—	dB
$N \pm 3$ Alternate channel selectivity	$C/I_3$	Interferer is reference signal at +3 MHz offset <sup>1 4 3 5</sup>	—	-42.4	—	dB
		Interferer is reference signal at -3 MHz offset <sup>1 4 3 5</sup>	—	-54.8	—	dB
Selectivity to image frequency	$C/I_{IM}$	Interferer is reference signal at image frequency with 1 MHz precision <sup>1 5</sup>	—	-42.1	—	dB
Selectivity to image frequency $\pm 1$ MHz	$C/I_{IM\_1}$	Interferer is reference signal at image frequency +1 MHz with 1 MHz precision <sup>1 5</sup>	—	-42.4	—	dB
		Interferer is reference signal at image frequency -1 MHz with 1 MHz precision <sup>1 5</sup>	—	-8.3	—	dB
Intermodulation performance	IM	$n = 3^6$	—	-23	—	dBm

**Note:**

1. 0.1% Bit Error Rate.
2. With non-ideal signals as specified in Bluetooth Test Specification RF-PHY.TS.5.0.1 section 4.7.1
3. Desired signal -67 dBm.
4. Desired frequency  $2402\text{ MHz} \leq F_c \leq 2480\text{ MHz}$ .
5. With allowed exceptions.
6. As specified in Bluetooth Core specification version 5.1, Vol 6, Part A, Section 4.4

#### 4.8 RF Receiver Characteristics for Bluetooth Low Energy at 2 Mbps

Unless otherwise indicated, typical conditions are:  $T_A = 25\text{ }^\circ\text{C}$ ,  $V_{DD} = 3.0\text{V}$ . RF center frequency 2.45 GHz. Measured on RF2G4\_IO2.

**Table 4.8. RF Receiver Characteristics for Bluetooth Low Energy at 2 Mbps**

Parameter	Symbol	Test Condition	Min	Typ	Max	Unit
Max usable receiver input level	SAT	Signal is reference signal, packet length is 37 bytes <sup>1</sup>	—	10	—	dBm
Sensitivity	SENS	Signal is reference signal, 37 byte payload <sup>1</sup>	—	-94.1	—	dBm
		With non-ideal signals <sup>2 1</sup>	—	-93.9	—	dBm
Signal to co-channel interferer	$C/I_{CC}$	(see notes) <sup>1 3</sup>	—	+6.0	—	dB
$N \pm 1$ Adjacent channel selectivity	$C/I_1$	Interferer is reference signal at +2 MHz offset <sup>1 4 3 5</sup>	—	-8.0	—	dB
		Interferer is reference signal at -2 MHz offset <sup>1 4 3 5</sup>	—	-8.8	—	dB
$N \pm 2$ Alternate channel selectivity	$C/I_2$	Interferer is reference signal at +4 MHz offset <sup>1 4 3 5</sup>	—	-42.2	—	dB
		Interferer is reference signal at -4 MHz offset <sup>1 4 3 5</sup>	—	-50.3	—	dB
$N \pm 3$ Alternate channel selectivity	$C/I_3$	Interferer is reference signal at +6 MHz offset <sup>1 4 3 5</sup>	—	-54.4	—	dB
		Interferer is reference signal at -6 MHz offset <sup>1 4 3 5</sup>	—	-55.4	—	dB
Selectivity to image frequency	$C/I_{IM}$	Interferer is reference signal at image frequency with 1 MHz precision <sup>1 5</sup>	—	-8.0	—	dB
Selectivity to image frequency $\pm 1$ MHz	$C/I_{IM\_1}$	Interferer is reference signal at image frequency +2 MHz with 1 MHz precision <sup>1 5</sup>	—	-42.2	—	dB
		Interferer is reference signal at image frequency -2 MHz with 1 MHz precision <sup>1 5</sup>	—	+6.0	—	dB
Intermodulation performance	IM	$n = 3^6$	—	-22.3	—	dBm

**Note:**

1. 0.1% Bit Error Rate.
2. With non-ideal signals as specified in Bluetooth Test Specification RF-PHY.TS.5.0.1 section 4.7.1
3. Desired signal -67 dBm.
4. Desired frequency  $2402\text{ MHz} \leq F_c \leq 2480\text{ MHz}$ .
5. With allowed exceptions.
6. As specified in Bluetooth Core specification version 5.1, Vol 6, Part A, Section 4.4

#### 4.9 RF Receiver Characteristics for Bluetooth Low Energy at 500 kbps

Unless otherwise indicated, typical conditions are:  $T_A = 25\text{ }^\circ\text{C}$ ,  $V_{DD} = 3.0\text{V}$ . RF center frequency 2.45 GHz. Measured on RF2G4\_IO2.

**Table 4.9. RF Receiver Characteristics for Bluetooth Low Energy at 500 kbps**

Parameter	Symbol	Test Condition	Min	Typ	Max	Unit
Max usable receiver input level	SAT	Signal is reference signal, packet length is 37 bytes <sup>1</sup>	—	10	—	dBm
Sensitivity	SENS	Signal is reference signal <sup>1</sup>	—	-100.1	—	dBm
		With non-ideal signals <sup>2 1</sup>	—	-99.3	—	dBm
Signal to co-channel interferer	$C/I_{CC}$	(see notes) <sup>1 3</sup>	—	+2.1	—	dB
$N \pm 1$ Adjacent channel selectivity	$C/I_1$	Interferer is reference signal at +1 MHz offset <sup>1 4 3 5</sup>	—	-9.0	—	dB
		Interferer is reference signal at -1 MHz offset <sup>1 4 3 5</sup>	—	-9.5	—	dB
$N \pm 2$ Alternate channel selectivity	$C/I_2$	Interferer is reference signal at +2 MHz offset <sup>1 4 3 5</sup>	—	-44.4	—	dB
		Interferer is reference signal at -2 MHz offset <sup>1 4 3 5</sup>	—	-51.9	—	dB
$N \pm 3$ Alternate channel selectivity	$C/I_3$	Interferer is reference signal at +3 MHz offset <sup>1 4 3 5</sup>	—	-44.3	—	dB
		Interferer is reference signal at -3 MHz offset <sup>1 4 3 5</sup>	—	-58.3	—	dB
Selectivity to image frequency	$C/I_{IM}$	Interferer is reference signal at image frequency with 1 MHz precision <sup>1 5</sup>	—	-44.4	—	dB
Selectivity to image frequency $\pm 1$ MHz	$C/I_{IM\_1}$	Interferer is reference signal at image frequency +1 MHz with 1 MHz precision <sup>1 5</sup>	—	-44.3	—	dB
		Interferer is reference signal at image frequency -1 MHz with 1 MHz precision <sup>1 5</sup>	—	-9.0	—	dB

**Note:**

1. 0.1% Bit Error Rate.
2. With non-ideal signals as specified in Bluetooth Test Specification RF-PHY.TS.5.0.1 section 4.7.1
3. Desired signal -72 dBm.
4. Desired frequency  $2402\text{ MHz} \leq F_c \leq 2480\text{ MHz}$ .
5. With allowed exceptions.

#### 4.10 RF Receiver Characteristics for Bluetooth Low Energy at 125 kbps

Unless otherwise indicated, typical conditions are:  $T_A = 25\text{ }^\circ\text{C}$ ,  $V_{DD} = 3.0\text{V}$ . RF center frequency 2.45 GHz. Measured on RF2G4\_IO2.

**Table 4.10. RF Receiver Characteristics for Bluetooth Low Energy at 125 kbps**

Parameter	Symbol	Test Condition	Min	Typ	Max	Unit
Max usable receiver input level	SAT	Signal is reference signal, packet length is 37 bytes <sup>1</sup>	—	10	—	dBm
Sensitivity	SENS	Signal is reference signal <sup>1</sup>	—	-104.5	—	dBm
		With non-ideal signals <sup>2 1</sup>	—	-104.2	—	dBm
Signal to co-channel interferer	$C/I_{CC}$	(see notes) <sup>1 3</sup>	—	+0.8	—	dB
$N \pm 1$ Adjacent channel selectivity	$C/I_1$	Interferer is reference signal at +1 MHz offset <sup>1 4 3 5</sup>	—	-13.1	—	dB
		Interferer is reference signal at -1 MHz offset <sup>1 4 3 5</sup>	—	-13.6	—	dB
$N \pm 2$ Alternate channel selectivity	$C/I_2$	Interferer is reference signal at +2 MHz offset <sup>1 4 3 5</sup>	—	-49.5	—	dB
		Interferer is reference signal at -2 MHz offset <sup>1 4 3 5</sup>	—	-56.9	—	dB
$N \pm 3$ Alternate channel selectivity	$C/I_3$	Interferer is reference signal at +3 MHz offset <sup>1 4 3 5</sup>	—	-47.0	—	dB
		Interferer is reference signal at -3 MHz offset <sup>1 4 3 5</sup>	—	-63.1	—	dB
Selectivity to image frequency	$C/I_{IM}$	Interferer is reference signal at image frequency with 1 MHz precision <sup>1 5</sup>	—	-49.5	—	dB
Selectivity to image frequency $\pm 1$ MHz	$C/I_{IM\_1}$	Interferer is reference signal at image frequency +1 MHz with 1 MHz precision <sup>1 5</sup>	—	-47.0	—	dB
		Interferer is reference signal at image frequency -1 MHz with 1 MHz precision <sup>1 5</sup>	—	-13.1	—	dB

**Note:**

1. 0.1% Bit Error Rate.
2. With non-ideal signals as specified in Bluetooth Test Specification RF-PHY.TS.5.0.1 section 4.7.1
3. Desired signal -79 dBm.
4. Desired frequency  $2402\text{ MHz} \leq F_c \leq 2480\text{ MHz}$ .
5. With allowed exceptions.



#### 4.11 High-Frequency Crystal

**Table 4.11. High-Frequency Crystal**

Parameter	Symbol	Test Condition	Min	Typ	Max	Unit
Crystal frequency	$f_{\text{HFXTAL}}$		—	38.4	—	MHz
Initial calibrated accuracy	$\text{ACC}_{\text{HFXTAL}}$		-10	—	+10	ppm
Temperature drift	$\text{DRIFT}_{\text{HFXTAL}}$	Across specified temperature range	-30	—	+30	ppm

## 4.12 GPIO Pins

Unless otherwise indicated, typical conditions are: VDD = 3.0 V.

**Table 4.12. GPIO Pins**

Parameter	Symbol	Test Condition	Min	Typ	Max	Unit
Leakage current	I <sub>LEAK_IO</sub>	MODEx = DISABLED, VDD = 1.71V	—	1.9	—	nA
		MODEx = DISABLED, VDD = 3.0 V	—	2.5	—	nA
		MODEx = DISABLED, VDD = 3.8 V T <sub>A</sub> = 125 °C	—	—	200	nA
Input low voltage <sup>1</sup>	V <sub>IL</sub>	Any GPIO pin	—	—	0.3 * VDD	V
Input high voltage <sup>1</sup>	V <sub>IH</sub>	Any GPIO pin	0.7 * VDD	—	—	V
Output low voltage	V <sub>OL</sub>	Sinking 20mA, VDD = 3.0 V	—	—	0.2 * VDD	V
		Sinking 8mA, VDD = 1.62 V	—	—	0.4 * VDD	V
Output high voltage	V <sub>OH</sub>	Sourcing 20mA, VDD = 3.0 V	0.8 * VDD	—	—	V
		Sourcing 8mA, VDD = 1.62 V	0.6 * VDD	—	—	V
GPIO rise time	T <sub>GPIO_RISE</sub>	VDD = 3.0V, C <sub>load</sub> = 50pF, SLEW-RATE = 4, 10% to 90%	—	8.4	—	ns
		VDD = 1.7V, C <sub>load</sub> = 50pF, SLEW-RATE = 4, 10% to 90%	—	13	—	ns
GPIO fall time	T <sub>GPIO_FALL</sub>	VDD = 3.0V, C <sub>load</sub> = 50pF, SLEW-RATE = 4, 90% to 10%	—	7.1	—	ns
		VDD = 1.7V, C <sub>load</sub> = 50pF, SLEW-RATE = 4, 90% to 10%	—	11.9	—	ns
Pull up/down resistance <sup>2</sup>	R <sub>PULL</sub>	pull-up: MODEn = DISABLE DOUT=1, pull-down: MODEn = WIREDORPULLDOWN DOUT = 0	35	44	55	kΩ
Maximum filtered glitch width	T <sub>GF</sub>	MODE = INPUT, DOUT = 1	—	26	—	ns

**Note:**

1. GPIO and RESETn input thresholds are proportional to the VDD supply.
2. GPIO and RESETn pull-ups connect to the VDD supply. Pull-downs on GPIO connect to VSS.

### 4.13 Microcontroller Peripherals

The MCU peripherals set available in BGM210P modules includes:

- 12-bit 1 Msp/s ADC
- Analog Comparators
- 16-bit and 32-bit Timers/Counters
- 24-bit Low Energy Timer for waveform generation
- 32-bit Real Time Counter
- USART (UART/SPI/SmartCards/IrDA/I2S)
- I<sup>2</sup>C peripheral interfaces
- 12 Channel Peripheral Reflex System

For details on their electrical performance, consult the relevant portions of Section 4 in the SoC's datasheet.

To learn which GPIO ports provide access to every peripheral, consult [6.3 Analog Peripheral Connectivity](#) and [6.4 Digital Peripheral Connectivity](#).

### 4.14 Typical Performance Curves

Typical performance curves indicate typical characterized performance under the stated conditions.

### 4.14.1 Antenna Radiation and Efficiency

Typical BGM210P radiation patterns and efficiency for the on-board chip antenna under optimal operating conditions are plotted in the figures that follow. Antenna gain and radiation patterns have a strong dependence on the size and shape of the application PCB the module is mounted on, as well as on the proximity of any mechanical design to the antenna.

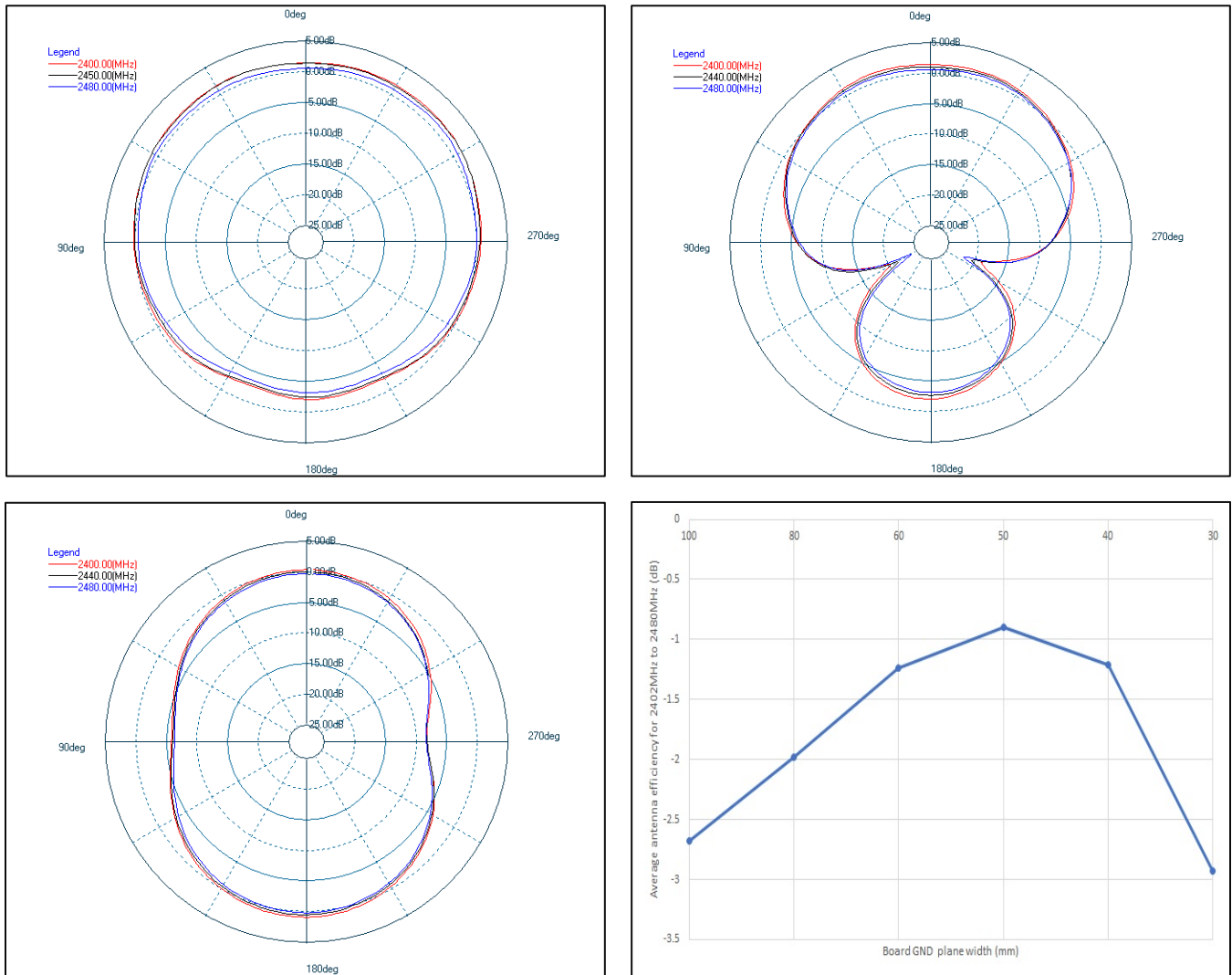

**Figure 4.1. Typical 2D Antenna Radiation Patterns and Efficiency**

Top Left: Phi 0°, Top Right: Phi 90°, Bottom Left: Theta 90°, Bottom Right: Radiation Efficiency vs Application Board GND Plane Width

## 5. Reference Diagrams

### 5.1 Network Co-Processor (NCP) Application with UART Host

The BGM210P can be controlled over the UART interface as a peripheral to an external host processor. Typical power supply, programming/debug interface, and host interface connections are shown in the figure below. For more details, refer to *AN958: Debugging and Programming Interfaces for Custom Designs*.

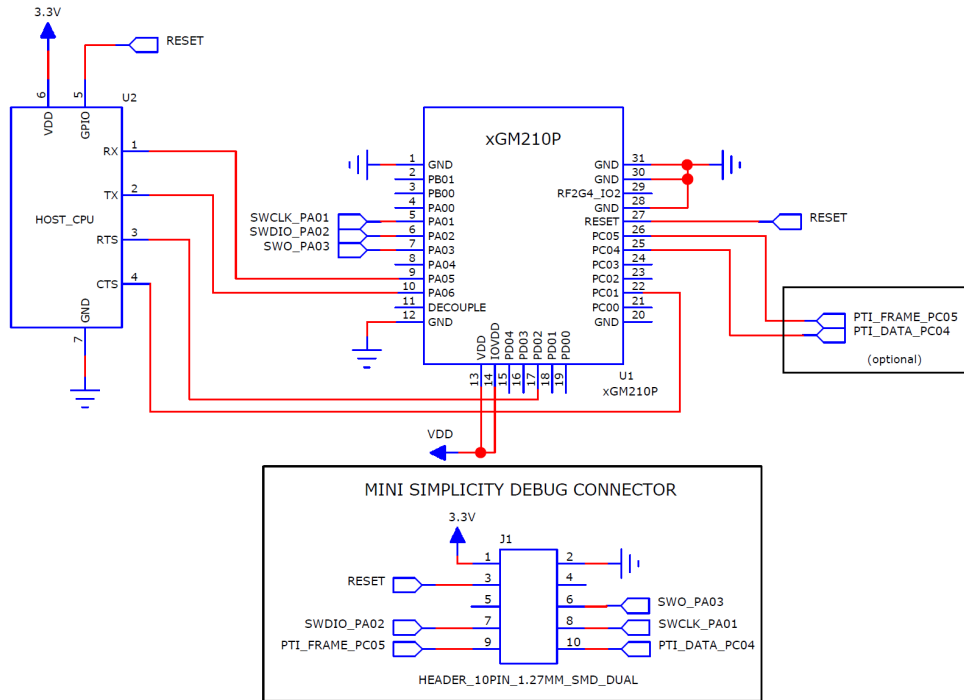

Figure 5.1. UART NCP Configuration

## 5.2 SoC Application

The BGM210P can be used in a stand-alone SoC configuration without an external host processor. Typical power supply and programming/debug interface connections are shown in the figure below. For more details, refer to *AN958: Debugging and Programming Interfaces for Custom Designs*.

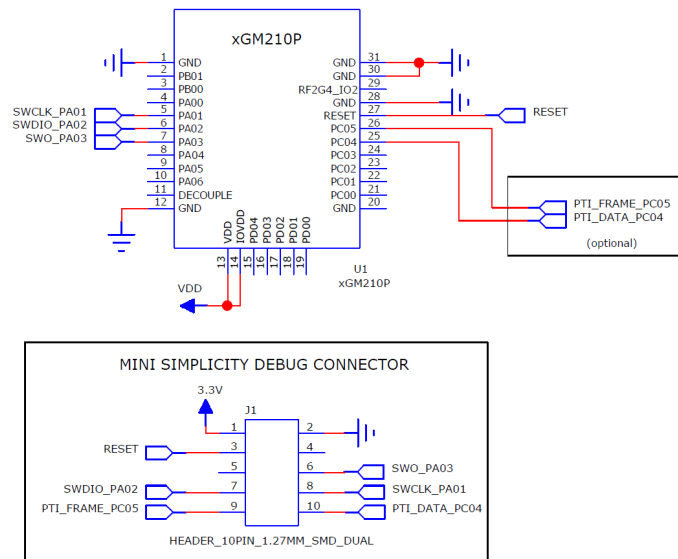

Figure 5.2. Stand-Alone SoC Configuration

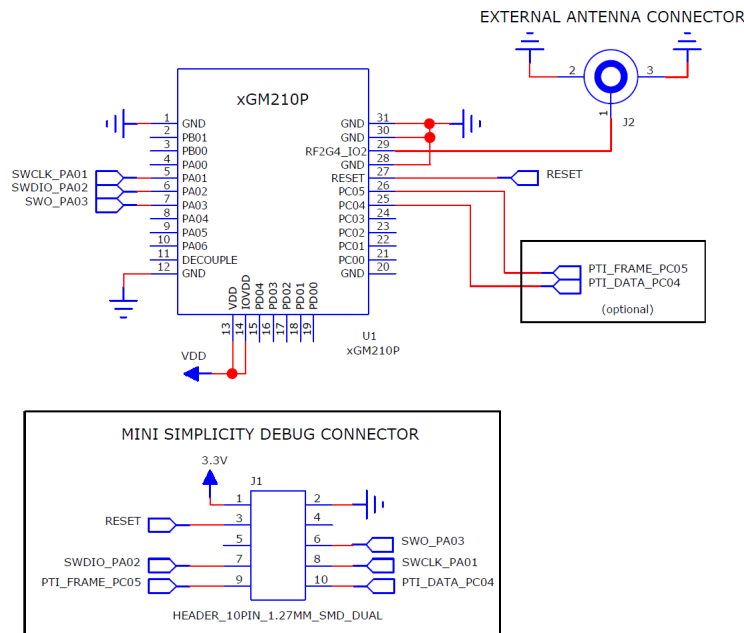

Figure 5.3. Stand-Alone SoC Configuration with External Antenna

## 6. Pin Definitions

### 6.1 Module Pinout

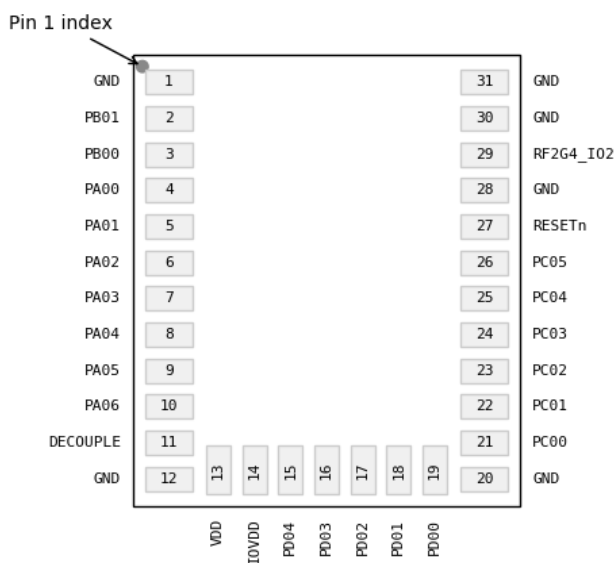

Figure 6.1. BGM210P Module Pinout

The next table shows the BGM210P pinout and some general descriptions of pin functionality. For more information on the features supported by each GPIO, see [6.3 Analog Peripheral Connectivity](#) and [6.4 Digital Peripheral Connectivity](#).

Table 6.1. BGM210P Module Pin Definitions

Pin Name	No.	Description	Pin Name	No.	Description
GND	1		PB01	2	GPIO
PB00	3	GPIO	PA00	4	GPIO
PA01	5	GPIO	PA02	6	GPIO
PA03	7	GPIO	PA04	8	GPIO
PA05	9	GPIO	PA06	10	GPIO
DECOUPLE	11	Decouple output for on-chip voltage regulator. An external decoupling capacitor is required at this pin.	GND	12	
VDD	13	Power supply	IOVDD	14	Digital IO power supply
PD04	15	GPIO	PD03	16	GPIO
PD02	17	GPIO	PD01	18	GPIO
PD00	19	GPIO	GND	20	
PC00	21	GPIO	PC01	22	GPIO
PC02	23	GPIO	PC03	24	GPIO
PC04	25	GPIO	PC05	26	GPIO
RESETn	27	Reset Pin	GND	28	
RF2G4_IO2	29	2.4 GHz RF input/output	GND	30	
GND	31				

## 6.2 Alternate Pin Functions

Some pins support multiple functions through internal multiplexing in the SoC (e.g. debugging, wake-up, etc.). The following table shows the functions available on each module pin. Refer to SoC's reference manual for more details.

**Table 6.2. GPIO Alternate Functions Table**

GPIO	Alternate Function		
PB01	GPIO.EM4WU3		
PA01	GPIO.SWCLK		
PA02	GPIO.SWDIO		
PA03	GPIO.SWV	GPIO.TDO	GPIO.TRACEDATA0
PA04	GPIO.TDI	GPIO.TRACECLK	
PA05	GPIO.EM4WU0		
PD02	GPIO.EM4WU9		
PD01	LFXO.LFXTAL_I	LFXO.LF_EXTCLK	
PD00	LFXO.LFXTAL_O		
PC00	GPIO.EM4WU6		
PC05	GPIO.EM4WU7		

## 6.3 Analog Peripheral Connectivity

Many analog resources are routable and can be connected to numerous GPIO's. The table below indicates which peripherals are available on each GPIO port. When a differential connection is being used Positive inputs are restricted to the EVEN pins and Negative inputs are restricted to the ODD pins. When a single ended connection is being used positive input is available on all pins. See the device Reference Manual for more details on the ABUS and analog peripherals.

**Table 6.3. ABUS Routing Table**

Peripheral	Signal	PA		PB		PC		PD	
		EVEN	ODD	EVEN	ODD	EVEN	ODD	EVEN	ODD
ACMP0	ana_neg	Yes	Yes	Yes	Yes	Yes	Yes	Yes	Yes
	ana_pos	Yes	Yes	Yes	Yes	Yes	Yes	Yes	Yes
ACMP1	ana_neg	Yes	Yes	Yes	Yes	Yes	Yes	Yes	Yes
	ana_pos	Yes	Yes	Yes	Yes	Yes	Yes	Yes	Yes
IADC0	ana_neg	Yes	Yes	Yes	Yes	Yes	Yes	Yes	Yes
	ana_pos	Yes	Yes	Yes	Yes	Yes	Yes	Yes	Yes



## 6.4 Digital Peripheral Connectivity

Many digital resources are routable and can be connected to numerous GPIO's. The table below indicates which peripherals are available on each GPIO port.

**Table 6.4. DBUS Routing Table**

Peripheral.Resource	PORT			
	PA	PB	PC	PD
ACMP0.DIGOUT	Available	Available	Available	Available
ACMP1.DIGOUT	Available	Available	Available	Available
CMU.CLKIN0			Available	Available
CMU.CLKOUT0			Available	Available
CMU.CLKOUT1			Available	Available
CMU.CLKOUT2	Available	Available		
FRC.DCLK			Available	Available
FRC.DFRAME			Available	Available
FRC.DOUT			Available	Available
I2C0.SCL	Available	Available	Available	Available
I2C0.SDA	Available	Available	Available	Available
I2C1.SCL			Available	Available
I2C1.SDA			Available	Available
LETIMER0.OUT0	Available	Available		
LETIMER0.OUT1	Available	Available		
PRS.ASYNCH0	Available	Available		
PRS.ASYNCH1	Available	Available		
PRS.ASYNCH10			Available	Available
PRS.ASYNCH11			Available	Available
PRS.ASYNCH2	Available	Available		
PRS.ASYNCH3	Available	Available		
PRS.ASYNCH4	Available	Available		
PRS.ASYNCH5	Available	Available		
PRS.ASYNCH6			Available	Available
PRS.ASYNCH7			Available	Available
PRS.ASYNCH8			Available	Available
PRS.ASYNCH9			Available	Available
PRS.SYNCH0	Available	Available	Available	Available
PRS.SYNCH1	Available	Available	Available	Available
PRS.SYNCH2	Available	Available	Available	Available
PRS.SYNCH3	Available	Available	Available	Available

Peripheral.Resource	PORT			
	PA	PB	PC	PD
TIMER0.CC0	Available	Available	Available	Available
TIMER0.CC1	Available	Available	Available	Available
TIMER0.CC2	Available	Available	Available	Available
TIMER0.CDTI0	Available	Available	Available	Available
TIMER0.CDTI1	Available	Available	Available	Available
TIMER0.CDTI2	Available	Available	Available	Available
TIMER1.CC0	Available	Available	Available	Available
TIMER1.CC1	Available	Available	Available	Available
TIMER1.CC2	Available	Available	Available	Available
TIMER1.CDTI0	Available	Available	Available	Available
TIMER1.CDTI1	Available	Available	Available	Available
TIMER1.CDTI2	Available	Available	Available	Available
TIMER2.CC0	Available	Available		
TIMER2.CC1	Available	Available		
TIMER2.CC2	Available	Available		
TIMER2.CDTI0	Available	Available		
TIMER2.CDTI1	Available	Available		
TIMER2.CDTI2	Available	Available		
TIMER3.CC0			Available	Available
TIMER3.CC1			Available	Available
TIMER3.CC2			Available	Available
TIMER3.CDTI0			Available	Available
TIMER3.CDTI1			Available	Available
TIMER3.CDTI2			Available	Available
USART0.CLK	Available	Available	Available	Available
USART0.CS	Available	Available	Available	Available
USART0.CTS	Available	Available	Available	Available
USART0.RTS	Available	Available	Available	Available
USART0.RX	Available	Available	Available	Available
USART0.TX	Available	Available	Available	Available
USART1.CLK	Available	Available		
USART1.CS	Available	Available		
USART1.CTS	Available	Available		
USART1.RTS	Available	Available		
USART1.RX	Available	Available		
USART1.TX	Available	Available		

Peripheral.Resource	PORT			
	PA	PB	PC	PD
USART2.CLK			Available	Available
USART2.CS			Available	Available
USART2.CTS			Available	Available
USART2.RTS			Available	Available
USART2.RX			Available	Available
USART2.TX			Available	Available

## 7. Design Guidelines

### 7.1 Layout and Placement

For optimal performance of the BGM210P,

- Place the module aligned to the edge of the application PCB, as illustrated in the figures below.
- Leave the antenna clearance area void of any traces, components, or copper on all layers of the application PCB if you are going to use the on-board chip antenna
  - Antenna clearance area is not necessary if you are using an external antenna attached to the RF pin.
  - For external antenna use cases, use a 50  $\Omega$  transmission line to trace the signal from the RF pin to an external RF connector if applicable (see [Figure 7.2 Recommended Layout for BGM210P Using External Antenna on page 28](#)).
- Connect all ground pads directly to a solid ground plane.
- Place the ground vias as close to the ground pads as possible.
- Do not place plastic or any other dielectric material in contact with the antenna.

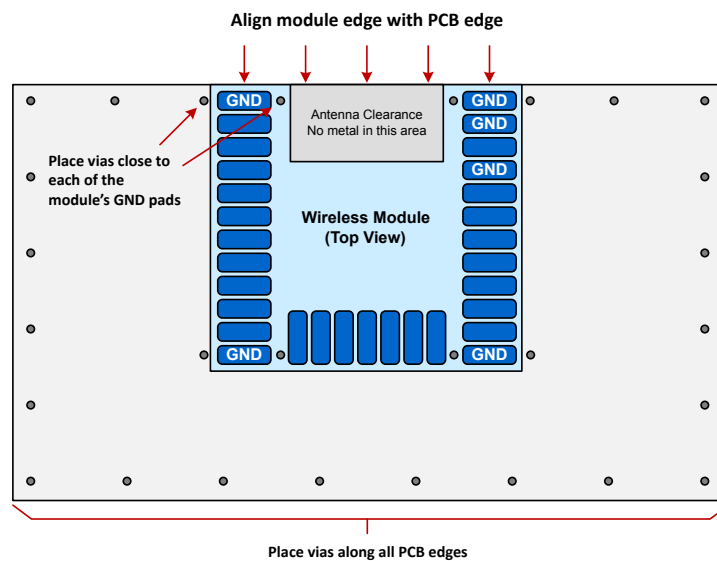

Figure 7.1. Recommended Layout for BGM210P Using On-Board Chip Antenna

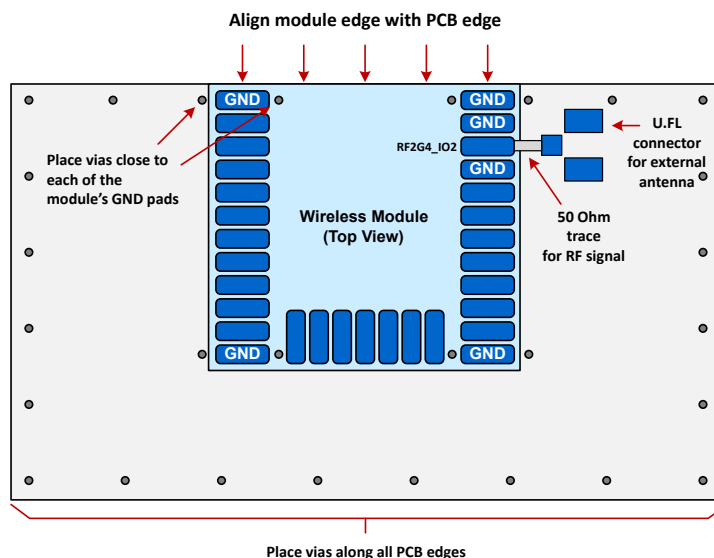
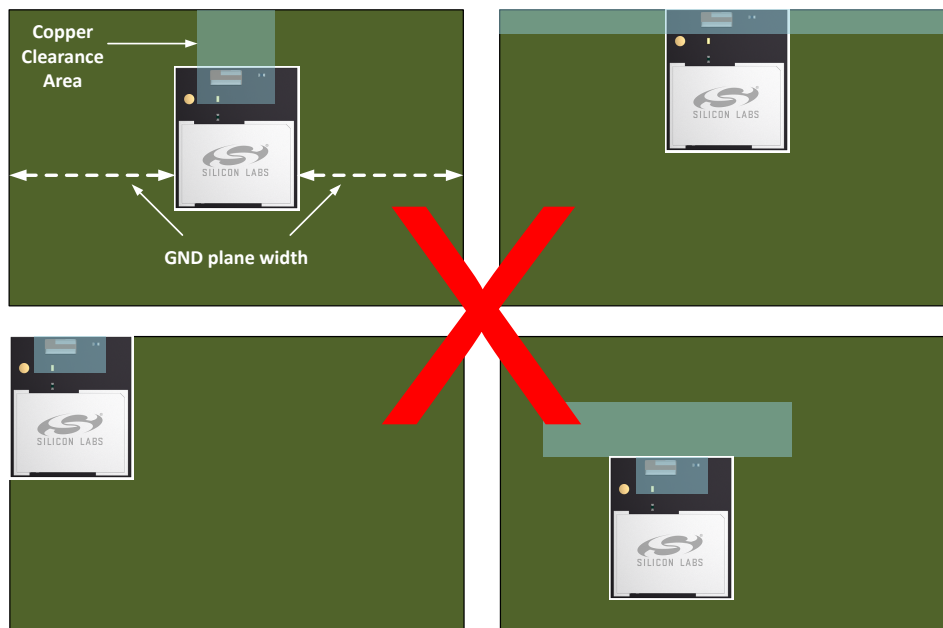

Figure 7.2. Recommended Layout for BGM210P Using External Antenna

The figure below illustrates layout scenarios that will lead to severely degraded RF performance for the module.



**Figure 7.3. Non-Optimal Layout Examples**

The width of the GND plane to the sides the module will impact the efficiency of the on-board chip antenna. To achieve optimal performance, a GND plane width of 50 mm is recommended. See [Figure 4.1 Typical 2D Antenna Radiation Patterns and Efficiency on page 20](#) for reference.

## 7.2 Proximity to Other Materials

Avoid placing plastic or any other dielectric material in close proximity to the antenna.

Any metallic objects in close proximity to the antenna will prevent the antenna from radiating freely. The minimum recommended distance of metallic and/or conductive objects is 10 mm in any direction from the antenna except in the directions of the application PCB ground planes.

## 7.3 Proximity to Human Body

Placing the module in contact with or very close to the human body will negatively impact antenna efficiency and reduce range.

## 8. Package Specifications

### 8.1 Dimensions

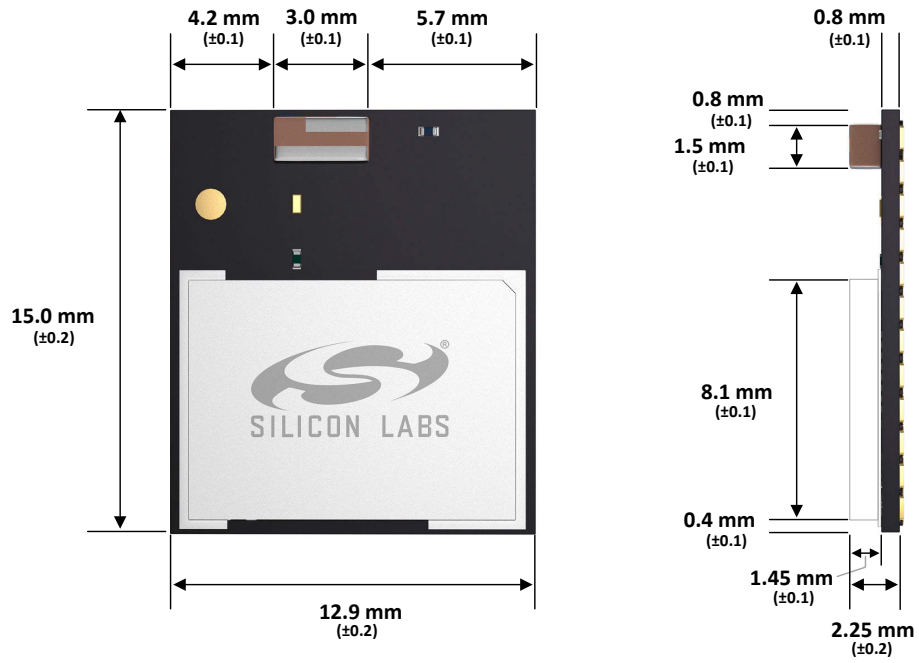

Figure 8.1. Module Dimensions

8.2 PCB Land Pattern

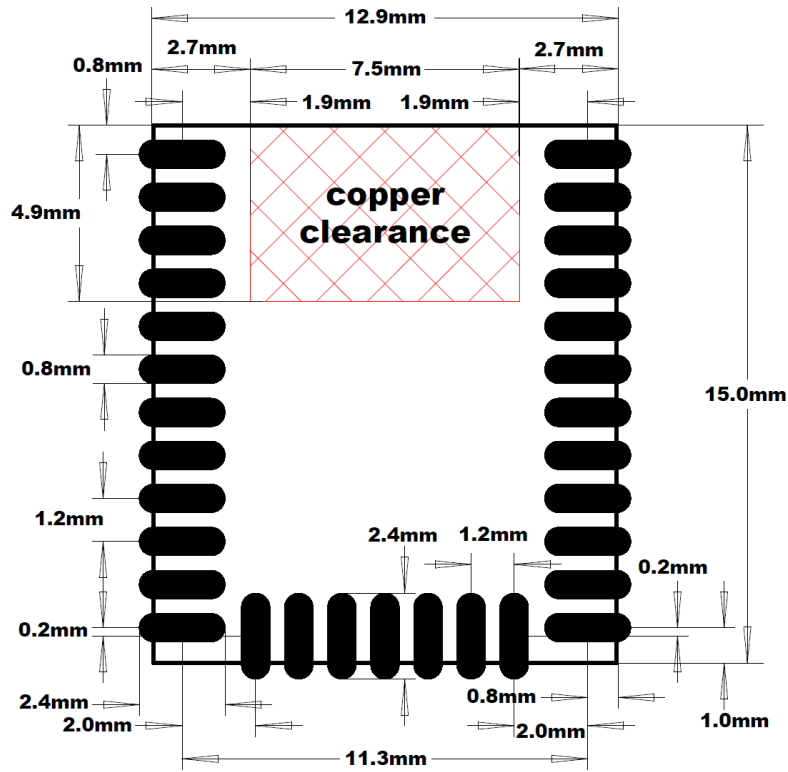

Figure 8.2. Land Pattern for Chip Antenna Use Case

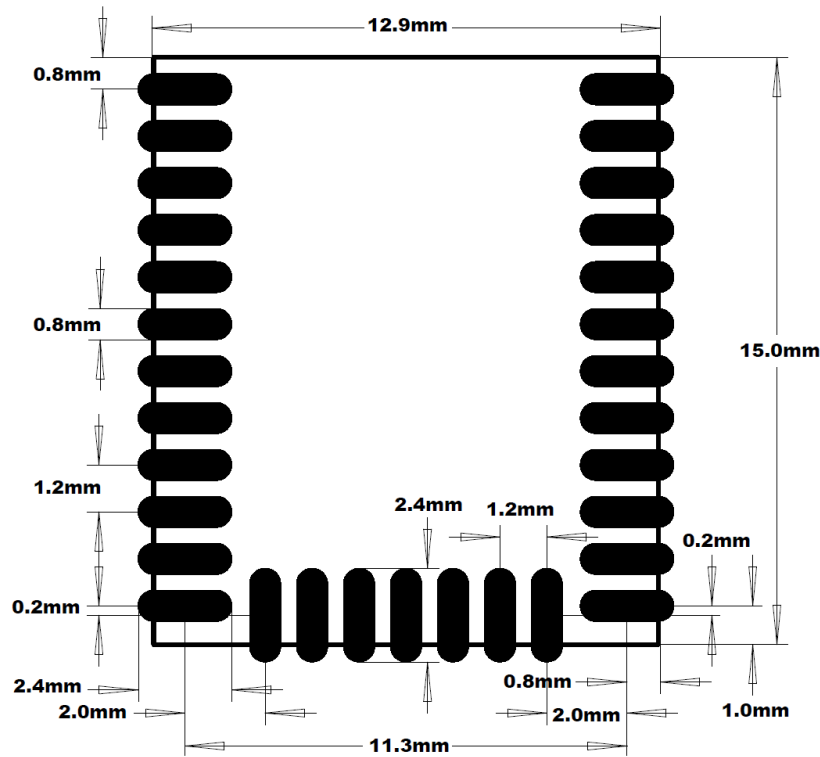

Figure 8.3. Land Pattern for RF Pin Use Case

### 8.3 Package Marking

The figure below shows the module markings engraved on the RF shield.



Figure 8.4. BGM210P Top Marking

#### Mark Description

The package marking consists of:

- BGM210Pxxxxxxx - Part number designation
- Model: BGM210Pxxx - Model number designation
- QR Code: YYWMMMMABCDE
  - YY – Last two digits of the assembly year.
  - WW – Two-digit workweek when the device was assembled.
  - MMABCDE – Silicon Labs unit code
- YYWWTTTTTTT
  - YY – Last two digits of the assembly year.
  - WW – Two-digit workweek when the device was assembled.
  - TTTTTT – Manufacturing trace code. The first letter is the device revision.
- Certification marks such as the CE logo, FCC and IC IDs, etc will be engraved in the gray area according to regulatory body requirements



## 9. Soldering Recommendations

It is recommended that final PCB assembly of the BGM210P follows the industry standard as identified by the Institute for Printed Circuits (IPC). This product is assembled in compliance with the J-STD-001 requirements and the guidelines of IPC-AJ-820. Surface mounting of this product by the end user is recommended to follow IPC-A-610 to meet or exceed class 2 requirements.

### **CLASS 1 General Electronic Products**

Includes products suitable for applications where the major requirement is function of the completed assembly.

### **CLASS 2 Dedicated Service Electronic Products**

Includes products where continued performance and extended life is required, and for which uninterrupted service is desired but not critical. Typically the end-use environment would not cause failures.

### **CLASS 3 High Performance/Harsh Environment Electronic Products**

Includes products where continued high performance or performance-on-demand is critical, equipment downtime cannot be tolerated, end-use environment may be uncommonly harsh, and the equipment must function when required, such as life support or other critical systems.

## 10. Tape and Reel

BGM210P modules are delivered to the customer in cut tape (100 pcs) or reel (1000 pcs) packaging with the dimensions below. All dimensions are given in mm unless otherwise indicated.

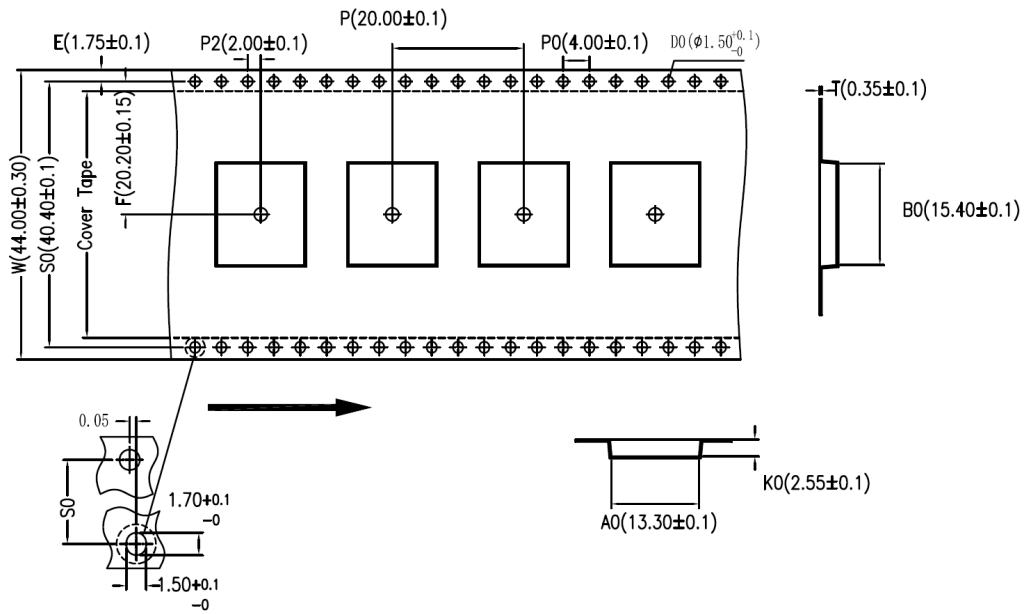

Figure 10.1. Carrier Tape Dimensions

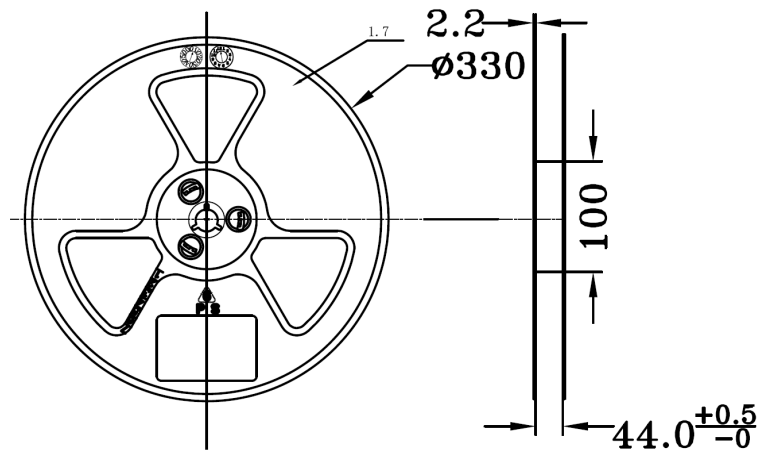

Figure 10.2. Reel Dimensions

## 11. Certifications

This section details the regulatory certification status of the module in various regions.

The address for the module manufacturer and certification applicant is:

SILICON LABORATORIES FINLAND OY  
Alberga Business Park, Bertel Jungin aukio 3,  
02600 Espoo, Finland

### 11.1 Qualified Antennas

BGM210P modules have been tested and certified both with the on-board chip antenna and with an external antenna attached to the RF pin (RF2G4\_IO2). Performance characteristics for the chip antenna are presented in [Table 3.1 Antenna Efficiency and Peak Gain on page 6](#) and [Figure 4.1 Typical 2D Antenna Radiation Patterns and Efficiency on page 20](#). Details for the external antenna qualified are summarized in the table below.

**Table 11.1. Qualified External Antennas for BGM210P**

Antenna Type	Maximum Gain	Impedance
Connectorized Coaxial Dipole	2.14 dBi	50 $\Omega$

Any antenna of the same general type and of equal or less directional gain as listed in the above table can be used in the regulatory areas that have a full modular radio approval (USA, Canada, Korea, Japan) as long as spot-check testing is performed to verify that no performance changes compromising compliance have been introduced. In countries applying the ETSI standards, like the EU countries, the radiated emissions are always tested with the end-product and the antenna type is not critical, but antennas with higher gain may violate some of the regulatory limits.

If an antenna of a different type (such as a chip antenna, a PCB trace antenna or a patch) with a gain less than or equal to 2.14 dBi is needed, it can be added as a permissive change, requiring some radiated emission testing. Antenna types with more gain than 2.14 dBi may require a fully new certification. Since the exact permissive change procedure is chosen on a case by case basis, please consult your test house and/or certification body for understanding the correct approach. You might also want or need to get in touch with Silicon Labs for any authorization letter that your certification body might ask for.

### 11.2 CE

The BGM210P module is in conformity with the essential requirements and other relevant requirements of the Radio Equipment Directive (RED) (2014/53/EU). Please note that every application using the BGM210P will need to perform the radio EMC tests on the end product, according to EN 301 489-17. It is ultimately the responsibility of the manufacturer to ensure the compliance of the end-product. The specific product assembly may have an impact to RF radiated characteristics, and manufacturers should carefully consider RF radiated testing with the end-product assembly. A formal Declaration of Conformity (DoC) is available via <https://www.silabs.com/>.

### 11.3 FCC

This device complies with Part 15 of the FCC Rules. Operation is subject to the following two conditions:

1. This device may not cause harmful interference, and
2. This device must accept any interference received, including interference that may cause undesirable operation.

Any changes or modifications not expressly approved by Silicon Labs could void the user's authority to operate the equipment.

### FCC RF Radiation Exposure Statement

This equipment complies with FCC radiation exposure limits set forth for an uncontrolled environment. End users must follow the specific operating instructions for satisfying RF exposure compliance. This transmitter meets both portable and mobile requirements in accordance to the limits exposed in the RF Exposure Analysis. This transmitter must not be co-located or operating in conjunction with any other antenna or transmitter except in accordance with FCC multi-transmitter product procedures.

## OEM Responsibilities to comply with FCC Regulations

This module has been tested for compliance to FCC Part 15.

OEM integrators are responsible for testing their end-product for any additional compliance requirements needed with this module installed (for example, digital device emissions, PC peripheral requirements, etc.). Additionally, investigative measurements and spot checking are strongly recommended to verify that the full system compliance is maintained when the module is integrated, in accordance to the "Host Product Testing Guidance" in FCC's KDB 996369 D04 Module Integration Guide V01.

### • General Considerations

This transmitter module is tested as a subsystem and its certification does not cover the FCC Part 15 Subpart B (unintentional radiator) rule requirement applicable to the final host. The final host will still need to be reassessed for compliance to this portion of rule requirements if applicable.

As long as all conditions above are met, further transmitter test will not be required. However, the OEM integrator is still responsible for testing their end-product for any additional compliance requirements required with this module installed.

### • Manual Information to the End User

The OEM integrator has to be aware not to provide information to the end-user regarding how to install or remove this RF module in the user's manual of the end product which integrates this module.

The end user manual shall include all required regulatory information/warnings as shown in this manual.

### • OEM/Host Manufacturer Responsibilities

OEM/Host manufacturers are ultimately responsible for the compliance of the Host and Module. The final product must be reassessed against all the essential requirements of the FCC rule such as FCC Part 15 Subpart B before it can be placed on the US market. This includes reassessing the transmitter module for compliance with the Radio and EMF essential requirements of the FCC rules. This module must not be incorporated into any other device or system without retesting for compliance as multi-radio and combined equipment.

## Separation

- To meet the SAR exemption for portable conditions, the minimum separation distance indicated in [Table 11.2 Minimum Separation Distances for SAR Evaluation Exemption on page 40](#) must be maintained between the human body and the radiator (antenna) at all times.
- This transmitter module is tested in a standalone mobile RF exposure condition, and in case of any co-located radio transmitter being allowed to transmit simultaneously, or in case of portable use at closer distances from the human body than those allowing the exceptions rules to be applied, a separate additional SAR evaluation will be required, ultimately leading to a Class II Permissive Change, or more rarely to a new grant.
- **Important Note:** In the event that these conditions cannot be met, the final product will have to undergo additional testing to evaluate the RF exposure in order for the FCC authorization to remain valid, and a permissive change will have to be applied. The evaluation (SAR) is in the responsibility of the end-product's manufacturer, as well as the permissive change that can be carried out with the help of the customer's own Telecommunication Certification Body as the grant holder's agent.

## End Product Labeling

BGM210P modules are labeled with their own FCC ID. If the FCC ID is not visible when the module is installed inside another device, then the outside of the device into which the module is installed must also display a label referring to the enclosed module. In that case, the final end product must be labeled in a visible area with the following:

**"Contains Transmitter Module FCC ID: QOQGM210P"**

Or

**"Contains FCC ID: QOQGM210P"**

The OEM integrator has to be aware not to provide information to the end user regarding how to install or remove this RF module or change RF related parameters in the user manual of the end product.

**Class B Device Notice**

This equipment has been tested and found to comply with the limits for a Class B digital device, pursuant to part 15 of the FCC Rules. These limits are designed to provide reasonable protection against harmful interference in a residential installation. This equipment generates, uses, and can radiate radio frequency energy and, if not installed and used in accordance with the instructions, may cause harmful interference to radio communications. However, there is no guarantee that interference will not occur in a particular installation. If this equipment does cause harmful interference to radio or television reception, which can be determined by turning the equipment off and on, the user is encouraged to try to correct the interference by one or more of the following measures:

- Reorient or relocate the receiving antenna
- Increase the separation between the equipment and receiver
- Connect the equipment into an outlet on a circuit different from that to which the receiver is connected
- Consult the dealer or an experienced radio/TV technician for help

## 11.4 ISED Canada

### ISED

This radio transmitter (IC: 5123A-GM210P) has been approved by *Innovation, Science and Economic Development Canada (ISED Canada, formerly Industry Canada)* to operate with the embedded antenna and with the antenna type(s) listed in [11.1 Qualified Antennas](#), with the maximum permissible gain indicated. Antenna types not included in this list, having a gain greater than the maximum gain listed, are strictly prohibited for use with this device.

This device complies with ISED's license-exempt RSS standards. Operation is subject to the following two conditions:

1. This device may not cause interference; and
2. This device must accept any interference, including interference that may cause undesired operation of the device

### RF Exposure Statement

Exception from routine SAR evaluation limits are given in RSS-102 Issue 5.

The module meets the given requirements when the minimum separation distance to human body is as indicated in [Table 11.2 Minimum Separation Distances for SAR Evaluation Exemption on page 40](#).

RF exposure or SAR evaluation is not required when the separation distance is same or more than stated above. If the separation distance is less than stated above the OEM integrator is responsible for evaluating the SAR.

### OEM Responsibilities to comply with IC Regulations

The module has been certified for integration into products only by OEM integrators under the following conditions:

- The antenna must be installed such that a minimum separation distance as stated above is maintained between the radiator (antenna) and all persons at all times.
- The transmitter module must not be co-located or operating in conjunction with any other antenna or transmitter.

As long as the two conditions above are met, further transmitter testing will not be required. However, the OEM integrator is still responsible for testing their end-product for any additional compliance requirements required with this module installed (for example, digital device emissions, PC peripheral requirements, etc.).

**Important Note:** In the event that these conditions cannot be met, the final product will have to undergo additional testing to evaluate the RF exposure in order for the ISED authorization to remain valid, and a permissive change will have to be applied with the help of the customer's own Telecommunication Certification Body typically acting as the certificate holder's agent.

### End Product Labeling

The BGM210P module is labeled with its own IC ID. If the IC ID is not visible when the module is installed inside another device, then the outside of the device into which the module is installed must also display a label referring to the enclosed module. In that case, the final end product must be labeled in a visible area with the following:

**“Contains Transmitter Module IC: 5123A-GM210P ”**

or

**“Contains IC: 5123A-GM210P”**

The OEM integrator has to be aware not to provide information to the end user regarding how to install or remove this RF module or change RF related parameters in the user manual of the end product.

### CAN ICES-003 (B)

This Class B digital apparatus complies with Canadian ICES-003.

## ISED (Français)

Le présent émetteur radio (IC: 5123A-GM210P) a été approuvé par Innovation, Sciences et Développement économique Canada pour fonctionner avec les types d'antenne énumérés au chapitre 11.1 et ayant un gain admissible maximal. Les types d'antenne non inclus dans cette liste, et dont le gain est supérieur au gain maximal indiqué pour tout type figurant sur la liste, sont strictement interdits pour l'exploitation de l'émetteur.

Ce composant est conforme aux normes RSS, exonérées de licence d'ISED. Son mode de fonctionnement est soumis aux deux conditions suivantes:

1. Ce composant ne doit pas générer d'interférences.
2. Ce composant doit pouvoir être soumis à tout type de perturbation y compris celle pouvant nuire à son bon fonctionnement.

## Déclaration d'exposition RF

L'exception tirée des limites courantes d'évaluation SAR est donnée dans le document RSS-102 Issue 5.

Les modèles BGM210P respectent les exigences d'exemption prévues lorsque la distance de séparation minimale entre le(s) antenne(s) et le corps humain est conforme aux valeurs indiquées dans le [Table 11.2 Minimum Separation Distances for SAR Evaluation Exemption on page 40](#).

La déclaration d'exposition RF ou l'évaluation DAS n'est pas nécessaire lorsque la distance de séparation est identique ou supérieure à celle indiquée ci-dessus. Si la distance de séparation est inférieure à celle mentionnées plus haut, il incombe à l'intégrateur OEM de procéder à une évaluation DAS.

La déclaration d'exposition RF ou l'évaluation SAR n'est pas nécessaire lorsque la distance de séparation est identique ou supérieure à celle indiquée ci-dessus. Si la distance de séparation est inférieure à celle mentionnées plus haut, il incombe à l'intégrateur OEM de procéder à une évaluation SAR.

## Responsabilités des OEM pour une mise en conformité avec le Règlement du Circuit Intégré

Le module a été approuvé pour l'intégration dans des produits finaux exclusivement réalisés par des OEM sous les conditions suivantes:

- L'antenne doit être installée de sorte qu'une distance de séparation minimale indiquée ci-dessus soit maintenue entre le radiateur (antenne) et toutes les personnes avoisinante, ce à tout moment.
- Le module émetteur ne doit pas être localisé ou fonctionner avec une autre antenne ou un autre transmetteur que celle indiquée plus haut.

Tant que les deux conditions ci-dessus sont respectées, il n'est pas nécessaire de tester ce transmetteur de façon plus poussée. Cependant, il incombe à l'intégrateur OEM de s'assurer de la bonne conformité du produit fini avec les autres normes auxquelles il pourrait être soumis de fait de l'utilisation de ce module (par exemple, les émissions des périphériques numériques, les exigences de périphériques PC, etc.).

**Remarque Importante:** Dans le cas où ces conditions ne peuvent être satisfaites (pour certaines configurations ou co-implantation avec un autre émetteur), l'autorisation ISED n'est plus considérée comme valide et le numéro d'identification ID IC ne peut pas être apposé sur le produit final. Dans ces circonstances, l'intégrateur OEM sera responsable de la réévaluation du produit final (y compris le transmetteur) et de l'obtention d'une autorisation ISED distincte.

## Étiquetage des produits finis

Les modules BGM210P sont étiquetés avec leur propre ID IC. Si l'ID IC n'est pas visible lorsque le module est intégré au sein d'un autre produit, cet autre produit dans lequel le module est installé devra porter une étiquette faisant apparaître les référence du module intégré. Dans un tel cas, sur le produit final doit se trouver une étiquette aisément lisible sur laquelle figurent les informations suivantes:

**“Contient le module transmetteur: 5123A-GM210P ”**

or

**“Contient le circuit: 5123A-GM210P”**

L'intégrateur OEM doit être conscient qu'il ne doit pas fournir, dans le manuel d'utilisation, d'informations relatives à la façon d'installer ou de d'enlever ce module RF ainsi que sur la procédure à suivre pour modifier les paramètres liés à la radio.

## 11.5 Proximity to Human Body

When using the module in an application where the radio is located close to the human body, the human RF exposure must be evaluated. FCC, ISED, and CE all have different standards for evaluating the RF exposure, and because of this, each standard requires a different minimum separation distance between the module and human body. Certification of BGM210P allows for the minimum separation distances detailed in the table below in portable use cases (less than 20 cm from human body). The module is approved for the mobile use case (more than 20 cm) without any need for RF exposure evaluation.

**Table 11.2. Minimum Separation Distances for SAR Evaluation Exemption**

Certification	BGM210P22A	BGM210P32A
FCC	5.3 mm	44.0 mm
ISED	20 mm	40 mm
CE	The RF exposure must always be evaluated using the end-product when transmitting with power levels higher than 20 mW (13 dBm).	

For FCC and ISED, using the module in end-products where the separation distance from the human body is smaller than that listed above is allowed but requires evaluation of the RF exposure in the final assembly and applying for a *Class 2 Permissive Change* or *Change of ID* to be applied to the existing FCC/ISED approvals of the module. For CE, RF exposure must be evaluated using the end-product in all cases when transmitting a more than the power level indicated in the table.

**Note:** Placing the module in touch or very close to the human body will have a negative impact on the efficiency of the antenna thus a reduced range is to be expected.



## 12. Revision History

### Revision 0.5

September, 2019

- Initial Production Release.
- Updated with latest values, certifications, security, etc
- Updated with OPNs for Reel packaging
- Added [System Overview](#)
- Updated [Electrical Specifications](#) with latest values
- Added [Reference Diagrams](#)
- Updated wording and figures in [Design Guidelines](#)
- Updated figures in [Package Specifications](#) and added Marking section
- Added [Tape and Reel](#) dimensions
- Updated [Certifications](#) information
- General wording, spelling, and grammar fixes.

### Revision 0.1

April, 2019

- Initial Release.

Silicon Labs

# Simplicity Studio™4



## Simplicity Studio

One-click access to MCU and wireless tools, documentation, software, source code libraries & more. Available for Windows, Mac and Linux!



IoT Portfolio  
[www.silabs.com/IoT](http://www.silabs.com/IoT)



SW/HW  
[www.silabs.com/simplicity](http://www.silabs.com/simplicity)



Quality  
[www.silabs.com/quality](http://www.silabs.com/quality)



Support and Community  
[community.silabs.com](http://community.silabs.com)

### Disclaimer

Silicon Labs intends to provide customers with the latest, accurate, and in-depth documentation of all peripherals and modules available for system and software implementers using or intending to use the Silicon Labs products. Characterization data, available modules and peripherals, memory sizes and memory addresses refer to each specific device, and "Typical" parameters provided can and do vary in different applications. Application examples described herein are for illustrative purposes only. Silicon Labs reserves the right to make changes without further notice to the product information, specifications, and descriptions herein, and does not give warranties as to the accuracy or completeness of the included information. Without prior notification, Silicon Labs may update product firmware during the manufacturing process for security or reliability reasons. Such changes will not alter the specifications or the performance of the product. Silicon Labs shall have no liability for the consequences of use of the information supplied in this document. This document does not imply or expressly grant any license to design or fabricate any integrated circuits. The products are not designed or authorized to be used within any FDA Class III devices, applications for which FDA premarket approval is required or Life Support Systems without the specific written consent of Silicon Labs. A "Life Support System" is any product or system intended to support or sustain life and/or health, which, if it fails, can be reasonably expected to result in significant personal injury or death. Silicon Labs products are not designed or authorized for military applications. Silicon Labs products shall under no circumstances be used in weapons of mass destruction including (but not limited to) nuclear, biological or chemical weapons, or missiles capable of delivering such weapons. Silicon Labs disclaims all express and implied warranties and shall not be responsible or liable for any injuries or damages related to use of a Silicon Labs product in such unauthorized applications.

### Trademark Information

Silicon Laboratories Inc.®, Silicon Laboratories®, Silicon Labs®, SiLabs® and the Silicon Labs logo®, Bluegiga®, Bluegiga Logo®, ClockBuilder®, CMEMS®, DSPLL®, EFM®, EFM32®, EFR, Ember®, Energy Micro, Energy Micro logo and combinations thereof, "the world's most energy friendly microcontrollers", Ember®, EZLink®, EZRadio®, EZRadioPRO®, Gecko®, Gecko OS, Gecko OS Studio, ISOModem®, Precision32®, ProSLIC®, Simplicity Studio®, SiPHY®, Telegesis, the Telegesis Logo®, USBXpress®, Zentri, the Zentri logo and Zentri DMS, Z-Wave®, and others are trademarks or registered trademarks of Silicon Labs. ARM, CORTEX, Cortex-M3 and THUMB are trademarks or registered trademarks of ARM Holdings. Keil is a registered trademark of ARM Limited. Wi-Fi is a registered trademark of the Wi-Fi Alliance. All other products or brand names mentioned herein are trademarks of their respective holders.



Silicon Laboratories Inc.  
400 West Cesar Chavez  
Austin, TX 78701  
USA

<http://www.silabs.com>