

# Signal Chain Power Passive Filter Board

## DESCRIPTION

Demonstration circuit SCP-FILTER-EVALZ is a companion hardware tool designed to allow passive RCL filter networks in a Signal Chain Power hardware evaluation matrix. It accommodates an Nth-order filter network as well as specialty 3-terminal feedthrough filters.

Like all boards in the Signal Chain Power series, this board is designed to be easily plugged into other SCP boards to form a complete signal chain power system, enabling fast evaluation of low power signal chains. To evaluate this board, some universal SCP hardware is required, namely:

- SCP-INPUT-EVALZ                    SCP-1X2BKOUT-EVALZ
- SCP-OUTPUT-EVALZ                SCP-5X1-EVALZ
- SCP-1X5BKOUT-EVALZ
- SCP-THRUBRD-EVALZ

To properly evaluate SCP series demo boards, you will need the SCP Configurator companion software. SCP Configurator can help you choose the right board and topology for your design.

**Design files for this circuit board are available.**

All registered trademarks and trademarks are property of their respective owners.

**Table 1. Performance Summary**

SYMBOL	PARAMETER	NOTES	MIN	TYP	MAX	UNITS
V <sub>IN(MAX)</sub>	Max Input Voltage				50	V
V <sub>OUT(MAX)</sub>	Max Output Voltage				50	V
I <sub>OUT(MAX)</sub>	Max Output Current				2	A

## BOARD IMAGE

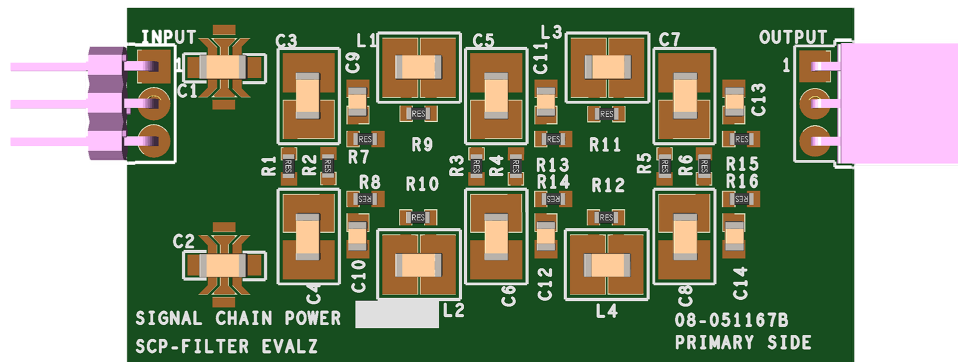

**Figure 1. Signal Chain Power Passive Filter Board**

## QUICK START PROCEDURE

Demonstration circuit SCP-FILTER-EVALZ is easy to set up to evaluate the performance of any SCP hardware configuration.

1. The SCP-FILTER-EVALZ ships with a bi-directional LED to indicate applied voltage. To set the limiting resistor, see “Configuration Settings” section, and modify the board accordingly. Be sure to check for open connections or solder shorts after making any modifications.
2. Connect the SCP-INPUT-EVALZ and SCP-OUTPUT-EVALZ boards to the SCP board under evaluation (refer to Figure 2) and connect the input board to a voltage source,  $V_{SOURCE}$ . Connect the output board to a voltmeter or dynamic load. Slowly raise the input voltage until the SCP-FILTER-EVALZ powers up the device under test into regulation and sweep  $V_{SOURCE}$  through the desired range of operation.

NOTE: Make sure that the input voltage is always within spec. If using a dynamic load to measure output voltage, make sure the load is initially set to zero.

3. Check for proper output voltage. The output should be regulated at the programmed value ( $\pm 5\%$ ).
4. Once the proper output voltage is established, power off  $V_{SOURCE}$  and similarly test other boards in the SCP system until all elements have been individually verified prior to assembling into the final circuit configuration.

NOTE: When measuring the input or output voltage ripple, use the optional SMA connector locations available on the input, output,  $1 \times 5$ ,  $1 \times 2$ , and  $5 \times 1$  breakout boards. Avoid using the test point connections with long scope leads.

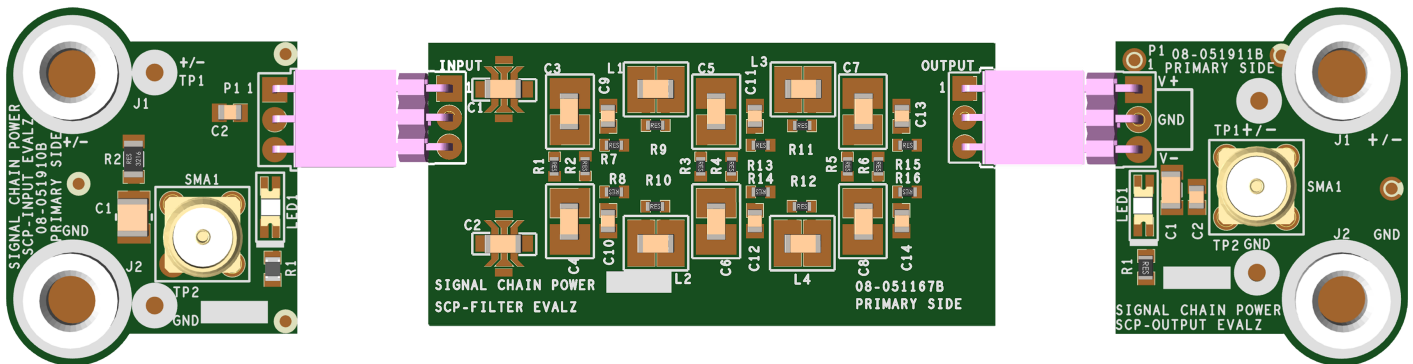

Figure 2. Proper Measurement Equipment Setup (Use SMA connectors for Measuring Input or Output Ripple)

## CONFIGURATION SETTINGS

Demonstration circuit SCP-FILTER-EVALZ is a companion hardware tool designed to allow passive RCL filter networks in a Signal Chain Power hardware evaluation matrix. It accommodates an Nth-order filter network as well as specialty 3-terminal feedthrough filters.

### FILTER CONFIGURATION

The filter board can be configured with standard L-C-R components to create multiple-ordered passive filter networks for those applications which might require selective notch filtering or cascaded low-pass networks.

Additionally, the filter boards feature a placement location for a highly effective 3-terminal feedthrough filter (TDK YFF series) on both positive and negative rails. This can be used alone or with additional ferrite beads placed across the series component locations.

If de-Q'ing is required to eliminate sharp resonances associated with ceramic capacitors and ferrite-based inductors, capacitors have series resistance elements and inductors have parallel resistance element options.

### FREQUENCY RESPONSE

The filter board PCB layout was designed to have as maximally flat frequency response as possible to test the actual effects of the chosen filter components.

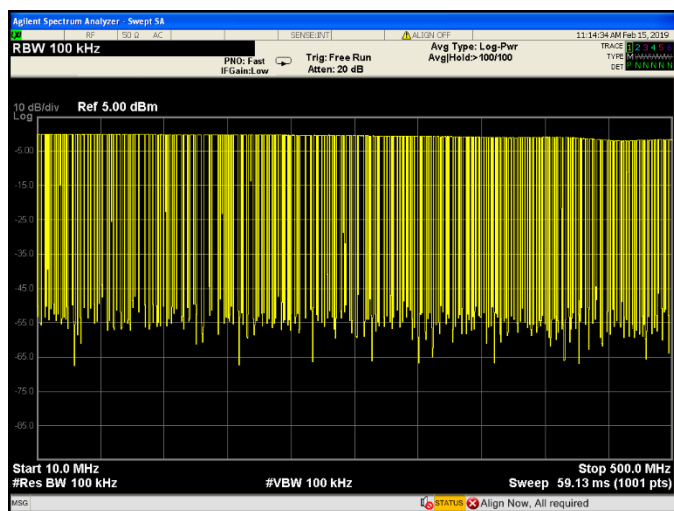

Figure 3. Swept spectrum power plot of filter board; series components shorted across; RBW: 100kHz; VBW: 100kHz

### 3-TERMINAL FEEDTHROUGH FILTER CONFIGURATION

Locations C1 and C2 support the TDK YFF series family of 3-terminal feedthrough capacitors. Refer to Figure 4 to utilize these locations for excellent RF noise suppression.

Table 2. TDK YFF Family (xx: size codes, see Table 3)

TDK PART #	FUNCTION
YFFxxPC	Feedthrough filter for power line
YFFxxPH	Feedthrough filter for power line
YFFxxPW	Feedthrough filter for power line
YFFxxHC	Feedthrough filter for high current line
YFFxxSC	Feedthrough filter for signal line

Table 3. TDK YFF Size Codes (xx from Table 2)

SIZE CODE	SIZE
15	1005 [0402 inch]
18	1608 [0603 inch]
21	2012 [0805 inch]
31	3216 [1206 inch]

To make shorting across the center ground pad easier when the component is not stuffed, the pad is intentionally isolated. When stuffing these filter components, make sure to bridge the pad to ground on both sides as shown in Figure 4.

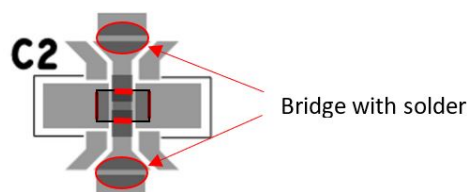

Figure 4. Connection for YFF center ground pad

# DEMO MANUAL SCP-FILTER-EVALZ

---

## PARTS LIST

ITEM	QTY	REFERENCE	PART DESCRIPTION	MANUFACTURER/PART NUMBER
1	1	PCB	PCB	ANALOG DEVICES 08_051167b
2	6	C9, C10, C11, C12, C13, C14	CAP MLCC 0805 (Note 1)	N/A
3	1	INPUT	CONN MALE 3POS 2.54MM PITCH R/A	SULLINS PBC03SBAN
4	1	OUTPUT	CONN FEMALE 3POS 2.54MM PITCH R/A	SULLINS PPPC031LGBN-RC
5	16	R1, R2, R3, R4, R5, R6, R7, R8, R9, R10, R11, R12, R13, R14, R15, R16	RES THICK FILM 0603 (Note 1)	N/A

**Note 1.** These items are not stuffed (DNI).

## SCHEMATIC DIAGRAM

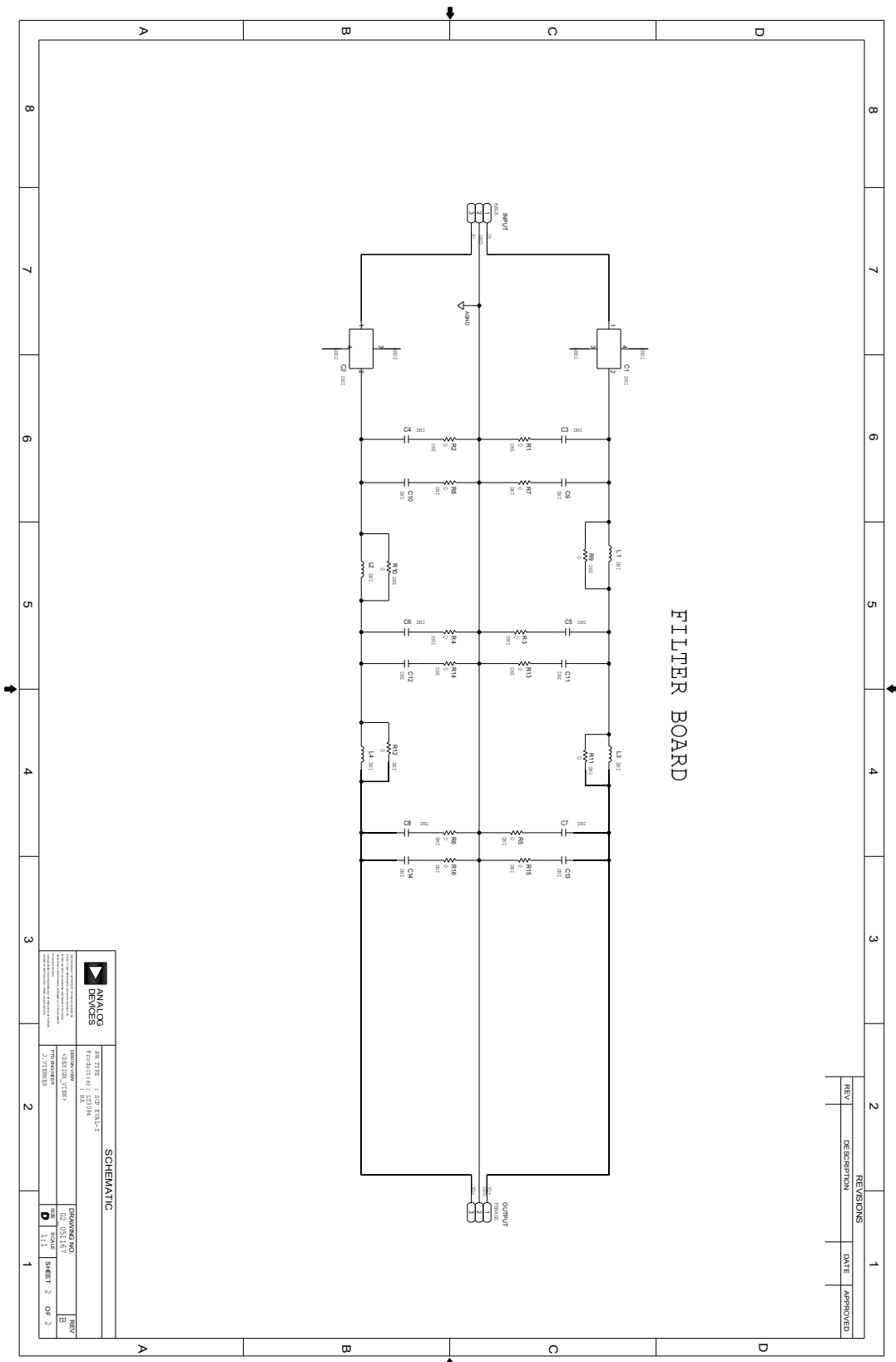

<b>ANALOG DEVICES</b>		<b>SCHEMATIC</b>	
DATE	REV	DRAWING NO.	REV
11/11	1	1000-0000-0000	1
DESIGNED BY	PROPOSED BY	PART NO. 1000-0000-0000	
J. STEINBERG	J. STEINBERG	SHEET 2 OF 2	

REV	DESCRIPTION	DATE	APPROVED

# DEMO MANUAL SCP-FILTER-EVALZ

---



## ESD Caution

**ESD (electrostatic discharge) sensitive device.** Charged devices and circuit boards can discharge without detection. Although this product features patented or proprietary protection circuitry, damage may occur on devices subjected to high energy ESD. Therefore, proper ESD precautions should be taken to avoid performance degradation or loss of functionality.

## Legal Terms and Conditions

By using the evaluation board discussed herein (together with any tools, components documentation or support materials, the "Evaluation Board"), you are agreeing to be bound by the terms and conditions set forth below ("Agreement") unless you have purchased the Evaluation Board, in which case the Analog Devices Standard Terms and Conditions of Sale shall govern. Do not use the Evaluation Board until you have read and agreed to the Agreement. Your use of the Evaluation Board shall signify your acceptance of the Agreement. This Agreement is made by and between you ("Customer") and Analog Devices, Inc. ("ADI"), with its principal place of business at One Technology Way, Norwood, MA 02062, USA. Subject to the terms and conditions of the Agreement, ADI hereby grants to Customer a free, limited, personal, temporary, non-exclusive, non-sublicensable, non-transferable license to use the Evaluation Board FOR EVALUATION PURPOSES ONLY. Customer understands and agrees that the Evaluation Board is provided for the sole and exclusive purpose referenced above, and agrees not to use the Evaluation Board for any other purpose. Furthermore, the license granted is expressly made subject to the following additional limitations: Customer shall not (i) rent, lease, display, sell, transfer, assign, sublicense, or distribute the Evaluation Board; and (ii) permit any Third Party to access the Evaluation Board. As used herein, the term "Third Party" includes any entity other than ADI, Customer, their employees, affiliates and in-house consultants. The Evaluation Board is NOT sold to Customer; all rights not expressly granted herein, including ownership of the Evaluation Board, are reserved by ADI. CONFIDENTIALITY. This Agreement and the Evaluation Board shall all be considered the confidential and proprietary information of ADI. Customer may not disclose or transfer any portion of the Evaluation Board to any other party for any reason. Upon discontinuation of use of the Evaluation Board or termination of this Agreement, Customer agrees to promptly return the Evaluation Board to ADI. ADDITIONAL RESTRICTIONS. Customer may not disassemble, decompile or reverse engineer chips on the Evaluation Board. Customer shall inform ADI of any occurred damages or any modifications or alterations it makes to the Evaluation Board, including but not limited to soldering or any other activity that affects the material content of the Evaluation Board. Modifications to the Evaluation Board must comply with applicable law, including but not limited to the RoHS Directive. TERMINATION. ADI may terminate this Agreement at any time upon giving written notice to Customer. Customer agrees to return to ADI the Evaluation Board at that time. LIMITATION OF LIABILITY. THE EVALUATION BOARD PROVIDED HEREUNDER IS PROVIDED "AS IS" AND ADI MAKES NO WARRANTIES OR REPRESENTATIONS OF ANY KIND WITH RESPECT TO IT. ADI SPECIFICALLY DISCLAIMS ANY REPRESENTATIONS, ENDORSEMENTS, GUARANTEES, OR WARRANTIES, EXPRESS OR IMPLIED, RELATED TO THE EVALUATION BOARD INCLUDING, BUT NOT LIMITED TO, THE IMPLIED WARRANTY OF MERCHANTABILITY, TITLE, FITNESS FOR A PARTICULAR PURPOSE OR NON-INFRINGEMENT OF INTELLECTUAL PROPERTY RIGHTS. IN NO EVENT WILL ADI AND ITS LICENSORS BE LIABLE FOR ANY INCIDENTAL, SPECIAL, INDIRECT OR CONSEQUENTIAL DAMAGES RESULTING FROM CUSTOMER'S POSSESSION OR USE OF THE EVALUATION BOARD, INCLUDING BUT NOT LIMITED TO LOST PROFITS, DELAY COSTS, LABOR COSTS OR LOSS OF GOODWILL. ADI'S TOTAL LIABILITY FROM ANY AND ALL CAUSES SHALL BE LIMITED TO THE AMOUNT OF ONE HUNDRED US DOLLARS (\$100.00). EXPORT. Customer agrees that it will not directly or indirectly export the Evaluation Board to another country, and that it will comply with all applicable United States federal laws and regulations relating to exports. GOVERNING LAW. This Agreement shall be governed by and construed in accordance with the substantive laws of the Commonwealth of Massachusetts (excluding conflict of law rules). Any legal action regarding this Agreement will be heard in the state or federal courts having jurisdiction in Suffolk County, Massachusetts, and Customer hereby submits to the personal jurisdiction and venue of such courts. The United Nations Convention on Contracts for the International Sale of Goods shall not apply to this Agreement and is expressly disclaimed.